

January 2013

# Flexible Urban Water Distribution Systems

Seneshaw Amare Tsegaye

University of South Florida, [seneshaw@mail.usf.edu](mailto:seneshaw@mail.usf.edu)

Follow this and additional works at: <http://scholarcommons.usf.edu/etd>

 Part of the [Civil Engineering Commons](#), [Climate Commons](#), and the [Water Resource Management Commons](#)

## Scholar Commons Citation

Tsegaye, Seneshaw Amare, "Flexible Urban Water Distribution Systems" (2013). *Graduate Theses and Dissertations*.  
<http://scholarcommons.usf.edu/etd/4597>

This Dissertation is brought to you for free and open access by the Graduate School at Scholar Commons. It has been accepted for inclusion in Graduate Theses and Dissertations by an authorized administrator of Scholar Commons. For more information, please contact [scholarcommons@usf.edu](mailto:scholarcommons@usf.edu).

# Flexible Urban Water Distribution Systems

by

Seneshaw Amare Tsegaye

A dissertation submitted in partial fulfillment  
of the requirements for the degree of  
Doctor of Philosophy  
Department of Civil and Environmental Engineering  
College of Engineering  
University of South Florida

Major Professor: Kalanithy Vairavamoorthy, Ph.D.  
Yogi Goswami, Ph.D.  
Daniel Yeh, Ph.D.  
Kamal Alsharif, Ph.D.  
Ricardo Izurieta, Dr.P.H.

Date of Approval:  
March 15, 2013

Keywords: Uncertainties, Genetic Algorithm, Flexibility Optimization, Decision Making Under Uncertainty, Decentralized Water Distribution Systems

Copyright © 2013, Seneshaw Amare Tsegaye

## **Acknowledgments**

I am very much indebted to several people that have contributed to the successful completion of my study in different ways.

First and foremost, I would like to express my most sincere thanks to Prof. Kala Vairavamoorthy, Dean of the Patel College of Global Sustainability (PCGS) at the University of South Florida (USF) who gave me the opportunity to undertake this work and for tirelessly guiding me throughout my study. I am extremely grateful for his continuous encouragement, critical observation, comments and valuable time. He gave me guidance when I needed it, let me explore when I wanted to, and I feel fortunate to have had the opportunity to work with him. Prof. Vairavamoorthy was very helpful to me not only in my studies but also in my private life. His generous support was key in all this endeavors and this work would not have been completed without his dedicated support and guidance. In addition I would like to thank Dr. Daniel Yeh, Dr. Kamal Alsharif, Dr. Ricardo Izurieta and Dr. Yogi Goswami for their time, serving on my committee and their support for my Ph.D. research.

I am greatly indebted to the research team and staff of PCGS. They provided me with valuable advice, helpful comments, and all kind of personal and

professional support. I would like to thank Dr. Kebreab Ghebremichael, Dr. Jochen Eckart, Krishna Khatri and Jotham Sempewo. This was a wonderful group that provided encouragement and support when I most needed them. They helped me by sharing their valuable comments, discussed with me critically, edited my dissertation and made my life easy in difficult times. I thank you all so much.

The support and encouragement I got from my friends and PhD colleagues Zhou Yi, Dr. Harrison Mutikanga and Dr. Frank Kizito are highly appreciated.

I would like to thank the Patel College of Global Sustainability, University of South Florida, USA and the Department of Civil Engineering, University of Birmingham, UK that provided me with all the support through my PhD study.

Last but not least, I am extremely thankful to my parents, brothers and sisters for their unflattering support throughout my academic career, and I strongly desire to pass my gratefulness to them. I cannot forget my parents who sent their care through a microphone from thousands of miles away. My sincere appreciation also extends to all my colleagues and friends that have provided me with assistance on various occasions.

## Table of Contents

List of Tables .....	v
List of Figures .....	vii
Abstract .....	xi
1 Introduction.....	1
1.1 Background.....	1
1.2 Problem Statement .....	7
1.3 Research Objectives .....	8
1.4 Structure of the Dissertation.....	9
2 Review on Flexibility and WDS Design- Basic Concepts.....	12
2.1 Introduction .....	12
2.2 Definition of Flexibility .....	12
2.3 Flexibility Versus Other Properties to Handling Change .....	15
2.3.1 Robustness .....	15
2.3.2 Adaptability.....	16
2.3.3 Agility.....	17
2.3.4 Changeability.....	17
2.4 Designing for Flexibility .....	18
2.4.1 Uncertainty Description and Modelling .....	19
2.4.2 Option Identification.....	20
2.4.2.1 Change Propagation Analysis (CPA) .....	22
2.4.2.2 Sensitivity Design Structure Matrix (sDSM).....	23
2.5 Water Distribution Systems and Uncertainties .....	26
2.5.1 Uncertainty in WDS Design .....	26
2.5.2 WDS Design Under Uncertainty .....	28
2.6 Reliability Based WDS Optimization .....	30
2.6.1 Hydraulic Failure .....	32
2.6.2 Mechanical Failure .....	33
2.6.3 Water Distribution System Reliability Measures .....	34
2.6.3.1 Flow Entropy .....	35
2.6.3.2 Resilience Index.....	37
2.6.3.3 Network Resilience .....	40
2.6.4 Discussion .....	41
3 Framework for Design of Flexible Water Distribution System.....	43
3.1 Introduction .....	43

3.2	Framework for Design of Flexibility Water Distribution System.....	44
3.2.1	Uncertainty Description .....	47
3.2.1.1	Uncertainty in Design of WDS.....	47
3.2.1.2	Scenario Development.....	51
3.2.2	Flexibility Options in WDS .....	53
3.2.2.1	System Design Options.....	54
3.2.2.2	System Management Option.....	56
3.2.2.3	System Element Options.....	57
3.2.3	Generating Flexibility .....	60
3.2.3.1	Centralized Flexible WDS .....	65
3.2.3.2	Clustered Flexible WDS .....	67
3.2.4	Flexibility Assessment and Decision Making Under Uncertainty .....	69
3.2.4.1	Flexibility Assessment.....	69
3.2.4.1.1	The Capability to Respond ( $C_{rs}$ ).....	73
3.2.4.1.2	The Capability to React ( $C_{ra}$ ).....	74
3.2.4.1.3	Optimal Flexibility ( $F_{opt}$ ) .....	75
3.2.4.2	Decision Making Under Uncertainty .....	76
3.3	Conclusions: Framework for Design of Flexible WDS.....	81
4	Optimization for Flexible Design of Centralized WDS.....	84
4.1	Introduction .....	84
4.2	Optimization Problem for Flexible Design of WDS .....	85
4.2.1	Basic Optimization for WDS .....	85
4.2.2	Unique Objective Function for Flexibility Optimization.....	88
4.3	Genetic Algorithm Optimization Model for Flexible WDS .....	92
4.3.1	Generation of Initial Population .....	96
4.3.2	Hydraulic Analysis for a Range of Uncertainties.....	98
4.3.3	Uncertainty Based Fitness Evaluation.....	99
4.3.3.1	Computation of Penalty Function .....	99
4.3.3.2	Fitness Evaluation.....	101
4.3.4	Generation of New Population Using Reproduction .....	102
4.3.5	Production of Successive Generation and Termination....	106
4.3.6	Guideline for the GA Based Flexibility Optimization .....	108
4.4	Hypothetical Test- GAFO Model .....	110
4.4.1	Input Pipe Data and GA Parameters .....	110
4.4.2	Input Spatial and Temporal Demand Growth .....	111
4.4.3	Design Variable and GAFO Objective Function .....	114
4.4.4	GAFO Process and Result Analysis .....	115
4.5	Conclusions: Optimization for Flexible WDS.....	123
5	Flexibility of Centralized WDS: Case Study, Mbale, Uganda.....	125
5.1	Introduction .....	125
5.2	Description of the Case Study Area .....	126
5.3	Mbale Water Supply Challenges .....	128
5.4	Development of Flexible Centralized WDS .....	131

5.4.1	Uncertainty Description and Scenario Development .....	131
5.4.2	Design Options Considered.....	138
5.4.3	Generation of Flexibility .....	139
5.4.3.1	WDS Design Alternative-1 (WDS-1).....	140
5.4.3.2	WDS Design Alternative-2 (WDS-2).....	142
5.4.4	Flexibility Assessment and Decision Making.....	145
5.4.4.1	Flexibility Assessment .....	145
5.4.4.1.1	Determination of the Capability to Respond.....	145
5.4.4.1.2	Determination of the Capability to React.....	148
5.4.4.1.3	Determination of the Level Flexibility ....	150
5.4.4.2	Choosing Between WDS Design Options .....	152
5.5	Conclusions: Flexibility of Centralized WDS .....	153
6	Optimization Model for Clustering WDS in Emerging Area.....	155
6.1	Introduction .....	155
6.2	The Proposed Clustering Method for Emerging Areas.....	158
6.2.1	Source-Demand Distance .....	159
6.2.2	Intra-cluster Demand and Topographic Homogeneity .....	159
6.3	Minimization of Source-Demand Distance .....	163
6.3.1	Identification of Source Centers: Water Source Clustering .....	164
6.3.2	Assignment of Demand Parcel to the Nearest Source .....	167
6.4	Maximization Intra-cluster Homogeneity and Connectivity Analysis.....	170
6.4.1	K-means for Clustering WSS.....	171
6.4.2	Intra-cluster Parcels Connectivity .....	175
6.5	Conclusions: Optimization for Clustering WDS.....	176
7	Flexibility of Clustered WDS: Case Study, Arua, Uganda.....	178
7.1	Introduction .....	178
7.2	General Description of the Area.....	179
7.3	Application of the Proposed Clustering Method .....	183
7.3.1	Source-Demand Distance Minimization .....	184
7.3.2	Maximizing Homogeneity: K-means Clustering .....	188
7.4	Flexibility of Clustered WDS: Case Study Arua, Uganda .....	191
7.4.1	Centralized and Clustered WDS.....	196
7.4.2	Assessing Flexibility of Clustered and Centralized WSS .....	200
7.5	Conclusions: Flexibility of Clustered WDS .....	208
8	Conclusions and Recommendations .....	210
8.1	Framework for Design of Flexible WDS .....	212
8.2	Optimization of Centralized WDS for Flexibility.....	215
8.3	Optimization of Clustered WDS for Flexibility.....	217
8.4	Future Potential Research .....	218

References .....	220
Appendices.....	232
Appendix 1 Water Source Grouping.....	233
Appendix 2 Investment Cost Comparison .....	234
A2.1 Water Collection .....	234
A2.2 Elevated Reservoirs .....	236
A2.3 Water Treatment Plant (WTP) .....	237
Appendix 3 Operation and Maintenance Cost Comparison.....	243
A3.1 Conventional WTP for Both Centralized and Clustered....	243
A3.2 SSF for Clustered and Conventional WTP for Centralized WSS .....	244
A3.3 Water Pumping Costs .....	246
Appendix 4 Overall Cost Comparison .....	248
A4.1 Both Centralized and Clusters WSS Involving Conventional WTP .....	249
A4.2 Conventional WTP for Centralized and SSF for Clusters .....	253



## List of Tables

Table 2.1 Methods for reliability measurement of WDS.....	35
Table 3.1 $F_{opt}$ value for alternative WDS under two different scenarios .....	80
Table 3.2 Opportunity losses associated with each option .....	80
Table 4.1 Design stages and future growth .....	112
Table 4.2 Uncertain demand scenarios .....	112
Table 4.3 Pipe cost.....	114
Table 4.4 Integer code representing the commercially available pipes .....	115
Table 4.5 Least cost for different selection scheme and crossover operator....	119
Table 4.6 Least cost for different scenarios.....	122
Table 5.1 List of scenarios considered (for Mbale town) .....	135
Table 5.2 Description of the scenarios considered.....	135
Table 5.3 Pipe material and laying costs .....	139
Table 5.4 The total cost of WDS-1 under all scenarios.....	142
Table 5.5 The total cost of WDS-2 under all scenarios.....	144
Table 5.6 Regret associated with the different design options .....	152
Table 6.1 Source distance comparison matrix.....	166
Table 6.2 The centroid of the source groups .....	167
Table 7.1 Socio-economic status and demand categories for parish areas .....	182
Table 7.2 Source groups and location of source centers.....	186
Table 7.3 Lists of scenario considered (for Arua town).....	194
Table 7.4 Cost of centralized WDS.....	198

Table 7.5 Cost of clustered WDN .....	200
Table 7.6 $C_{rs}$ value for centralized and clustered WSS .....	202
Table 7.7 $C_{ra}$ values of centralized and clustered WDS .....	205
Table 7.8 Regret associated with the different design options .....	207
Table A.1 Matrix for water source centers determination .....	233
Table A.2 Water collection for centralized WSS (real cost) .....	235
Table A.3 Water collection cost for clustered WSS (real cost).....	235
Table A.4 Water collection cost comparison.....	236
Table A.5 Construction cost of reservoirs .....	237
Table A.6 Construction cost of conventional WTP.....	240
Table A.7 Conventional WTP for centralize and SSF for clustered WSS .....	242
Table A.8 Cost for operation and maintenance of conventional WTP .....	243
Table A.9 Annual running cost for SSF .....	245
Table A.10 Annual running cost comparison (conventional Vs. SSF).....	245
Table A.11 Annual pumping cost for centralized and clustered WSS.....	247
Table A.12 Cost component for centralized WSS with conventional WTP .....	250
Table A.13 Cost components for clustered WSS with conventional WTP .....	251
Table A.14 Cost components for clustered WSS with SSF treatment .....	254

## List of Figures

Figure 1.1 Flexibility, robustness and deterministic design.....	5
Figure 1.2 Chapters included in the dissertation and their interconnection .....	11
Figure 2.1 Properties to handle change.....	18
Figure 2.2 sDSM (functional requirements and design variables) .....	24
Figure 3.1 The interconnection of Chapter 3 with other chapters .....	44
Figure 3.2 Flexible WDS design framework .....	46
Figure 3.3 Typology of uncertainties.....	48
Figure 3.4 Planning options: (a) one dimensional (b) scenario planning .....	51
Figure 3.5 A scenario tree (future water demand A at different time T) .....	53
Figure 3.6 Different WDS options .....	59
Figure 3.7 Typical relationship between level of flexibility and total cost .....	61
Figure 3.8 Initial investment and required adaptation .....	62
Figure 3.9 Centralized WDS spanning over range of uncertainties .....	66
Figure 3.10 Clustered WDS spanning over range of uncertainties .....	68
Figure 3.11 The range of response and adaptation, and associated cost .....	72
Figure 4.1 The interconnection of Chapter 4 with other chapters .....	85
Figure 4.2 Optimization objective function for all possible future states .....	90
Figure 4.3 GAFO model algorithm.....	95
Figure 4.4 Typology of the hypothetical WDS .....	111
Figure 4.5 WDS spanning over the range of scenario .....	113
Figure 4.6 GAFO progression (roulette-wheel with one-point crossover).....	117

Figure 4.7 GAFO progression (roulette-wheel with two-point crossover) .....	117
Figure 4.8 GAFO progression (ranking selection with one-point crossover).....	118
Figure 4.9 GAFO progression (ranking selection with two-point crossover) .....	118
Figure 4.10 Comparison of the best fitness values.....	119
Figure 4.11 Comparison of the average fitness values.....	120
Figure 4.12 GAFO model results for the flexible WDS .....	121
Figure 4.13 Traditional vs GAFO model result.....	122
Figure 5.1 The interconnection of Chapter 5 with other chapters .....	126
Figure 5.2 Geographic location of Mbale district.....	127
Figure 5.3 Mbale current settlement extent & water consumption category .....	128
Figure 5.4 Population forecast for Mbale town from 2020 to 2050 .....	129
Figure 5.5 Spatial growth to the north and south of the town .....	130
Figure 5.6 Scenario tree representing the future demand .....	134
Figure 5.7 Staged spatial growth for scenario $A_1T_0$ - $A_2T_1$ - $A_3T_2$ - $A_4T_3$ .....	137
Figure 5.8 Water demand for scenario $A_1T_0$ - $A_2T_1$ - $A_3T_2$ - $A_4T_3$ (in $m^3/d$ ).....	137
Figure 5.9 Spatial and temporal variation of water demand (A in $m^3/d$ ).....	138
Figure 5.10 Mbale WDS-1 in year (a) 2020, (b) 2030, (c) 2040, (d) 2050 .....	141
Figure 5.11 Mbale WDS-2 in year (a) 2020, (b) 2050.....	143
Figure 5.12 Range of response for WDS-1 and WDS-2.....	146
Figure 5.13 Cost of change for WDS-1 and WDS-2 .....	146
Figure 5.14 $C_{rs}$ value for WDS-1 and WDS-2.....	147
Figure 5.15 Range of adaptation for each design option.....	148
Figure 5.16 Cost of adaptation associated with each WDS design option.....	149
Figure 5.17 $C_{ra}$ values of WDS-1 and WDS-2 .....	150
Figure 5.18 The optimal flexibility value for each WDS option.....	151

Figure 6.1 The interconnection of Chapter 6 with other chapters .....	158
Figure 6.2 The proposed method for clustering WSS in emerging areas. ....	162
Figure 6.3 Assignment of parcels to the source center.....	164
Figure 6.4 Basic minimizing Euclidean norm algorithm .....	170
Figure 6.5 Basic K-means algorithm.....	173
Figure 6.6 Showing clustering using K-means algorithm.....	174
Figure 7.1 The interconnection of Chapter 7 with other chapters .....	179
Figure 7.2 Geographic location of Arua town .....	180
Figure 7.3 Predicted future population in Arua .....	180
Figure 7.4 Predicted spatial extent of Arua in year 2032 .....	181
Figure 7.5 Future water demand in Arua .....	182
Figure 7.6 (a) Available water sources and their groups; (b) Water-source centers (based on minimized Euclidean distance) .....	185
Figure 7.7 (a) Parcel assignment (Minimized Euclidean norm). (b) Parcel membership-M based on source-demand distance.....	187
Figure 7.8 (a) elevation in m (asl). (b) parcel demand in m <sup>3</sup> /d .....	188
Figure 7.9 (a) K-means clusters (b) Cluster after merging isolated parcels .....	189
Figure 7.10 (a) Cluster after re-distributing small groups (b) Final cluster .....	191
Figure 7.11 Scenario tree representing the future demand .....	193
Figure 7.12 Staged spatial growth for the town .....	194
Figure 7.13 Water demand scenarios (spatial and temporal- A in m <sup>3</sup> /d) .....	195
Figure 7.14 Staged development of centralized WDS for Arua town.....	197
Figure 7.15 Staged development of clustered WDS for Arua town.....	199
Figure 7.16 Range of response for centralized and clustered WDS .....	201
Figure 7.17 Cost of change for centralized and clustered WDS .....	201
Figure 7.18 Range of adaptation for centralized and clustered WDS .....	203

Figure 7.19 Cost of adaptation associated with each WDS design option.....	204
Figure 7.20 The optimal flexibility value for centralized and clustered WSS.....	206
Figure A.1 Unit construction cost of conventional filter WTPs in Uganda.....	239
Figure A.2 Unit construction cost of SSF .....	241
Figure A.3 Cost comparison between centralized and clustered systems (with conventional WTP).....	252
Figure A.4 Cost comparison between centralized WSS with conventional WTP and clustered systems with SSF .....	255

## **Abstract**

With increasing global change pressures such as urbanization and climate change, cities of the future will experience difficulties in efficiently managing scarcer and less reliable water resources. However, projections of future global change pressures are plagued with uncertainties. This increases the difficulty in developing urban water systems that are adaptable to future uncertainty.

A major component of an urban water system is the distribution system, which constitutes approximately 80-85% of the total cost of the water supply system (Swamee and Sharma, 2008). Traditionally, water distribution systems (WDS) are designed using deterministic assumptions of main model input variables such as water availability and water demand. However, these deterministic assumptions are no longer valid due to the inherent uncertainties associated with them. Hence, a new design approach is required, one that recognizes these inherent uncertainties and develops more adaptable and flexible systems capable of using their active capacity to act or respond to future alterations in a timely, performance-efficient, and cost-effective manner.

This study develops a framework for the design of flexible WDS that are adaptable to new, different, or changing requirements. The framework consists of two main parts.

The first part consists of several components that are important in the pre and post-processing of the least-cost design methodology of a flexible WDS. These components include: the description of uncertainties affecting WDS design, identification of potential flexibility options for WDS, generation of flexibility through optimization, and a method for assessing of flexibility. For assessment a suite of performance metrics is developed that reflect the degree of flexibility of a distribution system. These metrics focus on the capability of the WDS to respond and react to future changes. The uncertainties description focuses on the spatial and temporal variation of future demand.

The second part consists of two optimization models for the design of centralized and decentralized WDS respectively. The first model generates flexible, staged development plans for the incremental growth of a centralized WDS. The second model supports the development of clustered/decentralized WDS. It is argued that these clustered systems promote flexibility as they provide internal degrees of freedom, allowing many different combinations of distribution systems to be considered. For both models a unique genetic algorithm based flexibility optimization (GAFO) model was developed that maximizes the flexibility of a WDS at the least cost.



The efficacy of the developed framework and tools are demonstrated through two case study applications on real networks in Uganda. The first application looks at the design of a centralized WDS in Mbale, a small town in Eastern Uganda. Results from this application indicate that the flexibility framework is able to generate a more flexible design of the centralized system that is 4% – 50% less expensive than a conventionally designed system when compared against several future scenarios. In addition, this application highlights that the flexible design has a lower regret under different scenarios when compared to the conventionally designed system (a difference of 11.2m<sup>3</sup>/US\$). The second application analyzes the design of a decentralized network in the town of Aura, a small town in Northern Uganda. A comparison of a decentralized system to a centralized system is performed, and the results indicate that the decentralized system is 24% – 34% less expensive and that these cost savings are associated with the ability of the decentralized system to be staged in a way that traces the urban growth trajectory more closely. The decentralized clustered WDS also has a lower regret (a difference of 17.7m<sup>3</sup>/US\$) associated with the potential future conditions in comparison with the conventionally centralized system and hence is more flexible.

## 1 Introduction

### 1.1 Background

Increasing global change pressures such as climate change, population growth and urbanization, changes in social behavior and socio-economic conditions, ageing and deterioration of infrastructure, and emerging contaminants and technologies pose a challenge to the design and future operation of water distribution systems (WDS) (Khatri and Vairavamoorthy, 2007). As WDS are generally designed for horizons that span several decades and the investments for WDS constitute approximately 80-85% of the total cost of water supply systems, global change pressures result in long-lasting consequences (Savic, 2005; Swamee and Sharma 2008). Global change pressures, coupled with risks inherent in the existing conventional urban water management, will result in the challenge that cities in the future will experience difficulties in efficiently managing scarcer and less reliable water resources (Tsegaye et al., 2012; Segrave, 2007). In particular for WDS the global change pressures may affect the temporal and spatial distribution of the water demand and the safe yield of available water resources. As the global change pressures are associated with huge inherited uncertainties, it is difficult to make reasonable predictions on their consequences. There is the danger that the input parameters of WDS will change at multiple points during their long operational life spans of several

decades. Hence a major challenge faced by designers of WDS is how to accommodate major inherited uncertainties associated with future global change pressures (Babayan et al., 2007).

Traditional planning of WDS has been based on deterministic assumptions. For example, conventional designs are usually based on the assumption that all model input variables such as water demand and pipe friction characteristics are accurately known at the time of design (Giustolisi et al., 2009; Savic, 2005; Babayan et al., 2005). However, due to the inherit uncertainties associated with the global change pressures predicted conditions may show large deviation from actual conditions. In general the traditional deterministic approach to design could lead to WDS that are undersized and badly performing and/or oversized and under performing. In addition, the poor performance can result in increasing operational costs or huge coping costs of the users. In order to adapt these poorly performing WDS to the intended performance, unplanned adaptation measures are required, which can result in huge adaptation costs. Hence there is a growing consensus among researchers and practitioners that the traditional deterministic design approach is no longer suitable as it affects the costs and performance of the WDS.

An example for the consequences of the traditional deterministic planning approach in the light of future uncertainties is the water supply expansion project in the Skane region of Southern Sweden (Erlenkotter et al., 1989). Soon after

construction of the water supply expansion scheme had begun, the water consumption in the region unexpectedly declined. Some argued that the project would no longer be viable and should be reconsidered; others held that the decision was irrevocable and argued that the excess capacity of the system will permit better environmental management of the present water system. As a result the project completion was postponed by nine years, leading to a reduction of the planned distribution system expansion (Lund, 1988). The example of the Skane region projects highlights that when a deterministic approach is employed (when it is clear there are potential uncertainties), this can lead to consequences such as unnecessary investment and underperforming systems (Erlenkotter et al., 1989). Hence, there is a need for proactive approaches that incorporate an understanding of the challenges of global change pressures and the associated uncertainties at the design stage (Cunha and Sousa, 2010).

There is a growing consensus, among researchers and practitioners that future uncertainties have to be recognized in the design and operation of WDS (Hassan and de Neufville, 2006). Recently, a number of studies have contributed to this shift from traditional practices (Gomes et al., 2012; Giustolisi et al., 2009; Babayan et al., 2007; Babayan et al., 2005). There are many new approaches for the design of WDS where future uncertainties are incorporated into the problem formulation as a constraint on minimal system robustness or penalty for fitness function (Giustolisi et al., 2009; Babayan et al., 2005, Xu and Goulter, 1999). Hence the WDS optimization will result in a least cost and robust system that

provides predefined level of robustness. Robust WDS, sometimes called “rigid systems”, perform well under a changing environment without the need for physical changes in the WDS. However there are several drawbacks associated with robust designs. For example these systems do not offer the ability to change or adapt to changes in the external environment that were not foreseen at the time of planning and design (Ramirez, 2002; Saleh et al., 2001). Also a robust design tends to be over designed resulting in additional costs. As these designs are fixed, they lack the ability to downsize in response to reduced expectations (i.e not possible to exploit upside opportunities) (Cunha and Sousa, 2010; de Neufville 2004; Scholtes, 2007). Furthermore many robust design approaches only capture incremental uncertainties (such as modeling anomalies) and do not consider more substantial uncertainties associated with future change pressures. Hence the robust design approach, is not appropriate for designing systems that need to be staged in order to respond to uncertainties over time (as experienced with global change pressures).

Flexibility has been proposed as another approach to this problem, that allows a step wise evolution of the system in cost effective and performance efficient manner (Fricke and Schulz, 2005; Olewnik and Lewis, 2006; Saleh et al., 2001; Scholtes, 2007). In flexible design, the decision making process is not focused on one time step, but rather on several successive points in time. Flexibility provides the ability to design a system in stages, so that the system can follow closely the changing future trajectory. This provides the ability to

implement changes after the system has already been implemented. Flexibility, as defined by Eckart et al., (2011) is “the ability of urban drainage systems to use their active capacity to act, and respond to relevant alterations during operation, in a performance-efficient, timely and cost-effective way.” As postulated by Silver and de Weck, (2007) and Zhao and Tseng, (2003), increasing a system’s flexibility provides a potential solution to deal with uncertainties acting on systems which are required to adapt and evolve to future stages. Scholtes, (2007) also recognizes flexibility as way to transform risks associated with uncertainty into an opportunity. Flexibility claims to consider future uncertainties in the design of WDS to achieve the intended performance with minimal costs. Flexible design seems to be the most promising design approach for WDS to cope with the future uncertainties associated with global change pressures. Figure 1.1 shows the relationship between a system’s required objectives and its ability to respond to changes in the external environment.

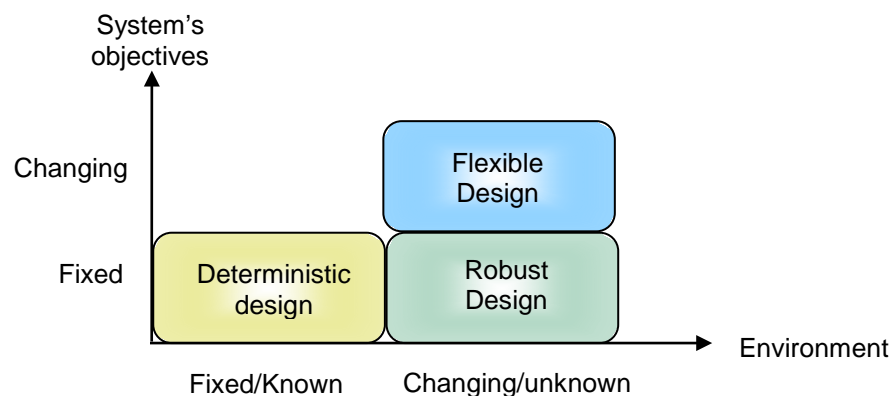

Figure 1.1 Flexibility, robustness and deterministic design

As shown in Figure 1.1 deterministic design is fixed and optimized to perform well for a fixed set of requirements and struggles to perform when there are changes in the external environment. A robust design is when design is fixed but has excess capacity and hence can cope within reason to variations in the external environment. Finally a flexible design is one that is not fixed and can adapt and change to changes in the external environment (Saleh et al., 2003).

Although the concept of flexibility has been considered in many areas including business, management, (Hocke and Heinzl, 2006), and building design (Fricke and Schulz, 2005; Neufville, 2004), it has not been applied to the design and management of urban WDS. The discussion of flexibility of WDS is in its infancy and still focuses on the question of the general appropriateness of flexibility. Tools for the operationalization flexible design for WDS are missing. Approaches to describing future uncertainties, metrics for measuring flexibility, and methods for the optimal design of flexible WDS, are missing in the technical literature. Hence, there is a challenge in operationalizing the concept of flexible design for WDS and so there is a need to develop new approaches and methodologies for this purpose. In addition to the above, there is a growing consensus the decentralization of WDS offers great opportunities to enhance their flexibility (PSGS 2010; Bieker et al., 2010). However, there has been little or no research on how to operationalize the decentralization approach, in particular guidance on how to define the boundaries of each of the clusters that make a decentralized system.

## 1.2 Problem Statement

The concept of flexibility has not been applied to the design and management of urban WDS. Such systems are critical for the welfare of society and as their performance is very sensitive to external pressures, it is critical that we develop methods and strategies to respond to the uncertainties associated with these pressures. It is required to operationalize the concept of flexible design for WDS. Hence there is a need to develop a framework for the development of flexible WDS. To achieve this it is important to address the following issues:

- What would be the appropriate metrics for evaluating and assessing the degree of flexibility of a WDS?
- What technical/management options enhance the flexibility of WDS?
- What should be the main steps taken in the design of a flexible WDS and how can these steps be incorporated into a comprehensive design framework?
- Can formal optimization methods be employed to optimize the flexibility of conventional centralized WDS?
- How can the flexibility of decentralized clustered WDS be optimized? How can concepts of decentralization and modular diversity be utilized to maximize flexibility of WDS?



### 1.3 Research Objectives

The main objective of this research is to develop a design framework that can generate optimal WDS that are adaptable and flexible under future global change pressures. These flexible systems are characterized by their ability to cope with uncertainties and hence have the capability to adapt to new, different, or changing requirements. The core of the framework consists of two optimization models, one for centralized WDS and the other for clustered WDS.

The specific objectives of the research will include:

- The development of pre and post-processing steps for the framework, including methods to describe the spatial and temporal demand uncertainties, performance metrics for the assessment of the degree of flexibility of a system, and rules for flexibility based decision making.
- The development of genetic algorithm based optimization model that maximizes the flexibility of centralized WDS at the least cost. This optimization model will generate a flexible, staged development plans for the incremental growth of the WDS.
- The development of an optimization model that divides emerging area into clusters that allows the provision of flexible, modular decentralized WDS. Modular diversity exponentially increases the amount of possible configurations that can be achieved for WDS from a given set of inputs (complex adaptive systems).

The above models will be combined to develop the design framework that will provide decision makers the ability to develop flexible WDS. This framework allows future urban water strategies to be assessed against a range of uncertainties, resulting in adaptable, flexible and sustainable solutions.

#### **1.4 Structure of the Dissertation**

Chapter 2 of this dissertation is a detailed literature review of the basic concepts of flexibility, WDS design, and the uncertainties associated with factors that impact water system design. In addition the chapter reviews existing reliability-based WDS optimization approaches and discusses their strengths and weaknesses.

Chapter 3 presents the detailed components of framework for the least-cost design of flexible WDS. As part of the development of the framework the chapter develops a scenario approach to describe potential future uncertainties, identifies different types of flexibility options for WDS, develops new metrics for measuring the degree of flexibility and describes the value of the *minimax* regret rule for flexibility-based-decision-making under uncertainty. The developed metrics include the capability of the distribution system to respond and react to future change. These metrics are combined in to a single metric called the 'optimal level of flexibility' metric.

Chapter 4 describes the development of an optimization model for the optimal flexible design of centralized WDS. The new tool, GAFO (Genetic Algorithm based Flexibility Optimization) sits at the center of the framework developed Chapter 3, and allows a wide range of uncertainties to be considered when designing the system. GAFO has two distinct features: it maximizes flexibility of the system; it enhances the changeability of the system through staged design and implementation.

Chapter 5 demonstrates the efficacy of the GAFO method for the flexible design of a centralized WDS for Mbale a small town in Eastern Uganda. The optimization was performed under conditions of uncertainties in respect to future demand. The results of this application indicate that the flexibility framework was able to generate a flexible staged design that is less expensive than a conventional designed system when compared against several future scenarios.

Chapter 6 describes the development of an optimization model that supports the development of clusters for decentralized WDS, which provide a huge flexibility. The clustering optimization model is based on two objectives: minimization of the distance from source to consumer using a Euclidean distance minimization approach and the maximization of the homogeneity within a cluster using a K-means approach.

Chapter 7 demonstrates the application of the optimization model for the identification of flexible clusters for WDS for the town of Aura, a small town in Northern Uganda. The results indicate that decentralized/clustered system is cheaper than conventional systems and that these cost savings are associated with the flexibility of the clustered system to be staged in a way that traces the urban growth trajectory more closely.

Chapter 8 describes the main conclusions of the dissertation and recommendations.

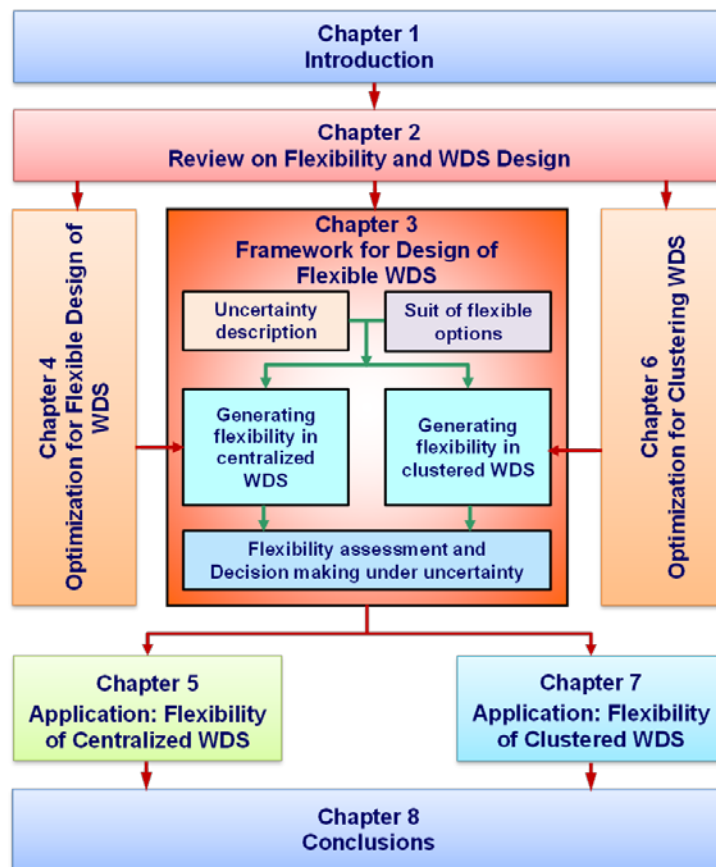

Figure 1.2 Chapters included in the dissertation and their interconnection

## **2 Review on Flexibility and WDS Design- Basic Concepts**

### **2.1 Introduction**

Traditional methods of designing WDS do not provide the chance to develop the system in an efficient and cost-effective way with the ability to cope with unexpected changes that threaten its value delivery. Alternatively, these issues can be managed through the design of flexible WDS that can follow different trajectories based on how the future unfolds. However, effective and beneficial implementation of this concept requires a profound investigation into the different features of flexibility and WDS design approaches. Hence, this chapter presents a brief review of the literature as it defines flexibility in different disciplines. It overviews the theoretical background of designing for flexibility and describes an approach to designing a WDS in consideration of future uncertainties.

### **2.2 Definition of Flexibility**

In recent years flexibility has become a key concept in many fields such as manufacturing, software engineering, architecture, finance, etc. Though many researchers have described the theoretical background and definition of flexibility, few have attempted to define the term formally and clearly for urban

water systems. For example, in his research on the management of manufacturing flexibility, Upton (1994) uses a very general and abstract definition of flexibility: “the ability to change or react with little penalty in time, effort, cost, or performance.” Allen et al., (2001) defined the word flexibility as the ease of changing the system’s requirements with a relatively small increase in complexity (and rework). According to Saleh et al. (2001), flexibility of a design is “the property of a system that allows it to respond to changes in its initial objectives and requirements—both in terms of capabilities and attributes—occurring after the system has been fielded, i.e., is in operation, in a timely and cost-effective way.” According to Olewnik and Lewis (2006), flexible systems are systems designed to maintain a high level of performance when operating conditions or requirements change in a predictable or unpredictable way. Schulz et al. (2000) and Fricke and Schulz (2005) define flexibility as a “system’s ability to be changed easily” in which external change factors “have to be implemented to cope with changing environments.” Shah et al. (2008) characterized flexibility as “the ability of a system to respond to potential internal or external changes affecting its value delivery, in a timely and cost-effective manner.”

Clearly, there is no one concrete definition of the concept. Most of the confusion about flexibility comes from the subtle distinctions between system features. Some of the definitions place emphasis on the ability to initiate change without referring to the change requirements; some emphasize the ability to maintain fixed requirements despite the change. According to Upton (1994),

constructing a definition of flexibility is not a straightforward matter, since definitions are often colored by a particular situation or problem. As such, three major gaps and discrepancies within the existing flexibility theories have been identified:

- i) The existing definition of flexibility for one system is often incompatible with another system. This highlights the need for customizing the existing definition of flexibility to UWS.
- ii) There is currently no description for measuring flexibility or ranking different designs according to their flexibility.
- iii) There is currently some overlap between the concept of flexibility and other properties for handling change such as changeability, adaptability, agility, and robustness (Fricke and Schulz, 2005). These properties are discussed in detail in section 2.3 below.

A clear definition of flexibility should be field-specific, provide a time reference associated with the occurrence of change, a characterization of what is changing, and an indication for providing metrics of flexibility (Saleh et al., 2001). Recently, a new definition of flexibility for UWS was developed by Eckart et al. (2010) based on the existing general definitions, in which flexibility is “the ability of urban water systems to use their active capacity to act and to respond on relevant alterations in a performance-efficient, timely and cost-effective way.” This definition covers the basic characteristics of flexibility (the capability to respond, the capability to react, and the characteristics of change processes) and

the indicators of flexibility (costs of change, range of change, and system performance) that are used in this study. As such, this is the definition of flexibility adopted in this work.

### **2.3 Flexibility Versus Other Properties to Handling Change**

There has always been confusion between the concept of flexibility and other properties of a system related to handling future change and variability. These properties include robustness, adaptability, agility, and changeability. In order to avoid confusion between these properties and to recognize the distinct characteristic differences of flexibility, the definitions of all these features are summarized in this section. There are already different approaches to differentiate between the different terms of changeability. Fricke and Schulz (2005) define flexibility as a sub-aspect of the overall term changeability and differentiate it from robustness, adaptability, and agility. In addition, Ross et al. (2008) reconcile the terms flexibility, adaptability, scalability, and robustness.

#### **2.3.1 Robustness**

Robustness is defined as “the property of a system which allows it to satisfy a fixed set of requirements, despite changes occurring in the environment or within the system itself” (Saleh et al., 2001). It is also defined as the ability to remain “constant” in parameters despite internal and external changes to a system (Ross et al., 2008). One of the major differences between robustness and flexibility is the response to the changing environment. Robust systems perform



well under a changing environment *without acting or responding to the change*. These systems are insensitive to variability and sometimes are called “rigid systems.” In contrast, flexible systems *respond to a changing environment through change*. In other words, while robust systems remain unchanged during their whole design lives in order to maintain their value delivery, flexible systems need to be changed several times in their design lives to do the same.

### **2.3.2 Adaptability**

Adaptability is defined as a “system’s ability to adapt itself towards changing environments” (Fricke and Schulz, 2005). Adaptability is thus similar to flexibility. However, the major difference between adaptability and flexibility is that of the location of the change agent with respect to the system boundary. Adaptation is the property of a system that allows it to cope with change through *internal change initiators* (internal system boundaries), whereas flexibility adapts through *external change initiators* (external system boundaries) (Shah et al., 2008). Like flexible systems, adaptable systems can change themselves to cope with the change requirement. Thus, the location of the change initiator needs to be identified in order to avoid confusion between flexibility and adaptability. There is also a similarity between adaptability and robustness in that robustness is considered an essential property for adaptation because adaptability is an evolutionary stage of robustness (Ross et al., 2008)

### **2.3.3 Agility**

Unlike flexibility and adaptability, which describe the location of the change initiator in a system, agility describes the nature of the change that occurs within the system (Ross et al., 2008). The ability to change in a short duration of time is a system's agility (Fricke and Schulz, 2005). Thus, quickness is the measure of agility. A system that allows different types of change in a short period of time is more agile than a system that requires a long duration. Agility also refers to the ease of change, and according to Fricke and Schulz (2005), it requires change to be implemented from an external agent to cope with the variability of the environment.

### **2.3.4 Changeability**

Changeability is defined as the ability of a system to change easily. According to Ross et al. (2008), the changeability of a system is determined by the number of acceptable change paths that the system can take. The number of acceptable change paths is determined both by the possible number of outcomes and the number of mechanisms that allow the change. Changeability often refers to the four properties used to handle future changes, which include adaptability, flexibility, agility, and robustness (Fricke and Schulz, 2005). All these properties incorporate changeability in a system throughout its entire life. The interrelationship of these properties as they form a system's changeability is depicted in Figure 2.1 (Fricke and Schulz, 2005).

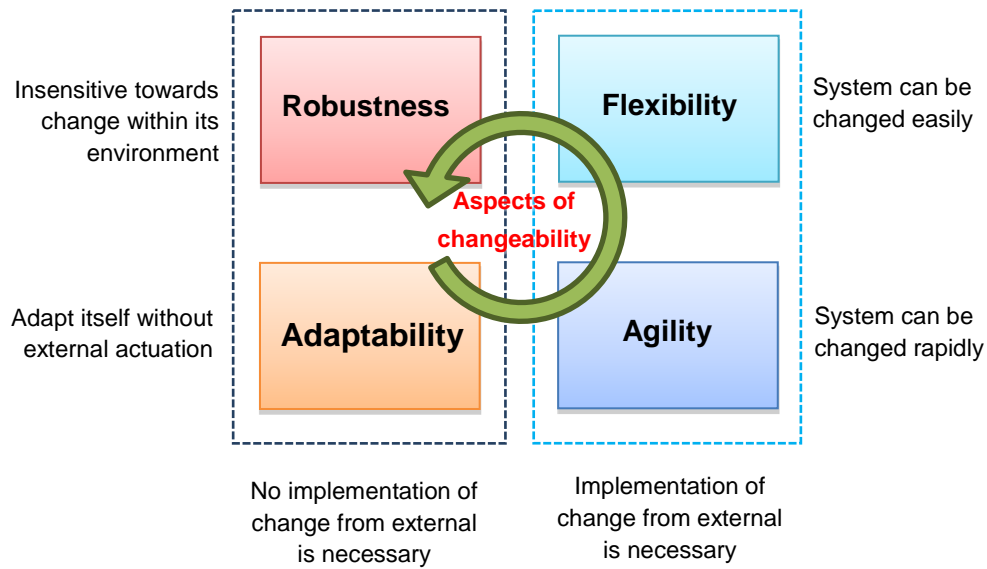

Figure 2.1 Properties to handle change

## 2.4 Designing for Flexibility

Most of the literature that deals with designing for flexibility addresses the issues related to uncertainty modelling, identifying options and/or system alternatives, generating and valuing flexibility, and decision making (Shah et al., 2008); (Ramirez, 2002); (Cardin and Neufville, 2008). For example, Shah et al. (2008) develop a three 'D' (Dice, Design & Decision, and Discounting) concept in response to the common problem of uncertainty that faces system design. The first part of the concept, *Dice*, represents the uncertain future within which the engineering solution will deliver a benefit. *Design & Decision* represents the designers' control over current design choices and, as the design allows, over choices in the future in response to the resolution of uncertainty. *Discounting* describes future benefits and costs associated with subsequent contingent

decisions that need to be discounted back to a common point in time so that different design options can be compared. Comparable frameworks for the designing flexibility are presented by different authors. Nilchiani and Hastings (2007) proposed an approach based on system analysis for the development of flexible designs. De Neufville (2000) used principles from real option analysis to generate a framework for the design of flexible systems entitled 'Dynamic Strategic Planning'. In general, designing for flexibility is characterized by the four major element frameworks discussed in the following sections.

#### ***2.4.1 Uncertainty Description and Modelling***

The description of unknown future conditions is the most important factor in the design of flexible WDS. WDS are facing major challenges throughout their life cycles due to the increasing uncertainties that will affect them. These uncertainties are usually caused by dynamic global change pressures and associated variability. The future conditions will certainly differ from the past trends and are difficult to predict. A statistical analysis of recorded trends and a stochastic generation of various possible future sequences have been done to account for the future variations. Since the statistical characteristics are themselves uncertain, there is no assurance that generated sequences are representative of the range of sequences that might occur in the future (Beard, 1982).

Flexibility has value precisely because of uncertainty. The capacity of uncertainty to be resolved in the future is usually understood as the characteristic that allows it to generate value (Ramirez, 2002). Uncertainty is therefore identified as a key element of flexibility. It creates both risks and opportunities in a system, and it is with the existence of uncertainty that flexibility becomes valuable (Nilchiani, 2005).

Uncertainties can be modeled using a number of different methods, including a scenario based approach (Arboleda and Abraham, 2006) in which various future states are described as members of families of discrete possibilities, as well as sampling type methods such as Monte Carlo Simulation (MCS) (Nilchiani and Hastings, 2007) and others. As a general rule, scenario based uncertainty modelling methods are relatively simple, but normally work only under certain assumptions (e.g., independent, discrete, etc.). The sampling type methods tend to be more general, but they are also much more computationally demanding. The choice of a particular method depends on the information available, though none of the methods give precise results (Nilchiani, 2005).

#### **2.4.2 Option Identification**

In finance literature, options are defined as the “right, but not the obligation” to take an action. The key feature of an option is the cost of exercising the option and of using one’s right to act. It is in this respect that an option has

value (de Neufville, 2001). Real options are options that relate to physical assets rather than financial instruments. Real options can be categorized as those that are either “in” or “on” projects. In engineering systems, flexibility is also identified as both “in” and “on” a system, where flexibility “in” a system is a technical aspect of the design that enables the system to adapt to its environment, and flexibility “on” a system relates to a management decision that does not alter technical components (de Neufville, 2002). For example, the flexibility to defer WDS expansion for a specific phase is non-technical and therefore is flexibility “on” a system. Most of the sources for flexibility “on” a system are well known. Some examples of this for urban water systems include investment deferral, multistage deployment, and expansion.

According to de Neufville and Cardin (2008) flexible design options (FDO) is the physical components that enable flexibility “in” a system. The design of flexible systems that have the ability to thrive in an ever-changing environment often requires identification of the options of flexibility for the system. Most flexibility options are not generic for different types of systems, but instead must be verified for specific types of system such as WDS. Shah et al. (2008) describe this verification of specific flexibility options as the main challenge for the application of real option analysis for different types of engineering systems. Furthermore, de Neufville and Cardin (2008) confirm that the identification of the options of flexibility that are specific to each system is essential. Identification of potential flexible options has been discussed often in the literature, and several

techniques have been used to identify flexible options. Some of these are change propagation analysis, sensitivity design structure matrix, engineering systems matrix, interview method, screening method, etc. However, the appropriateness of the methods depends on the type of system and the source of uncertainty in each case. The first two of these methodologies are discussed below.

#### **2.4.2.1 Change Propagation Analysis (CPA)**

In a complex system, in which all parts are closely linked, changes to one part or system are highly likely to result in changes to another, which in turn can propagate further reactions. Change Propagation Analysis (CPA) (Eckert et al., 2004) is used to analyze how a change in system components will propagate through a system. This method identifies the interaction between components by exploring the influence of a change in each component on the other components in the system. To measure the degree of change propagation for a single element, a Change Propagation Index (CPI) is used as a matrix. The CPI for a particular element expresses the difference between the amounts of change information  $\Delta E_{in}$  propagating “in” a component from components connected upstream and the amount of change  $\Delta E_{out}$  propagating “out” to other downstream components (see Equation 2.1).

$$CPI_i = \Delta E_{in,i} - \Delta E_{out,i} \quad 2.1$$

The terms 'multiplier', 'carrier', and 'absorber' have been defined by Eckert et al. (2004) to classify elements that react to changes. These terminologies are related to CPI as listed below.

- i) Multipliers ( $CPI > 0$ ): elements that generate more changes than they absorb.
- ii) Carriers ( $CPI = 0$ ): elements that absorb a similar number of changes to those that they cause themselves.
- iii) Absorbers ( $CPI < 0$ ): elements that can absorb more change than they themselves cause.

Eckert et al. (2004) also define the term 'constants' for a system as components that are unaffected by change. The CPA method looks at how a change in one component propagates through the other components in the system. Application of this method for WDS may demand high computational effort in order to explore the effect of change in each component on the other components of a system. Moreover, analyzing the effect of changing scenarios (uncertainties) on each component of WDS could be a better approach for identifying flexible options in WDS.

#### **2.4.2.2 Sensitivity Design Structure Matrix (sDSM)**

Kalligeros (2006) examines how changes in the functional requirements of a system propagate through the design variables using sDSM, as proposed by Yassine and Falkenburg (1999). Unlike the DSM representation of the system,



which is identical for all designs, the sDSM refers to a particular design because it represents only the sensitivity between design variables. sDSM is used to express the sensitivity of design variables and functional requirements of a system to changes in other design variables and functional requirements.

Functional requirements refer to performance levels that depend on the design variables of the system. For example, sDSM representation of a particular design variant for a particular set of design variables, denoted as  $X=[X_1, X_2, \dots, X_k]$ , and functional requirements denoted by a vector  $FR = [FR_1, FR_2, \dots, FR_k]$ , where  $k$  is the total number of functional requirements for a system is shown in Figure 2.2. sDSM can be defined as a square matrix with  $k$  rows and columns (Kalligeros, 2006).

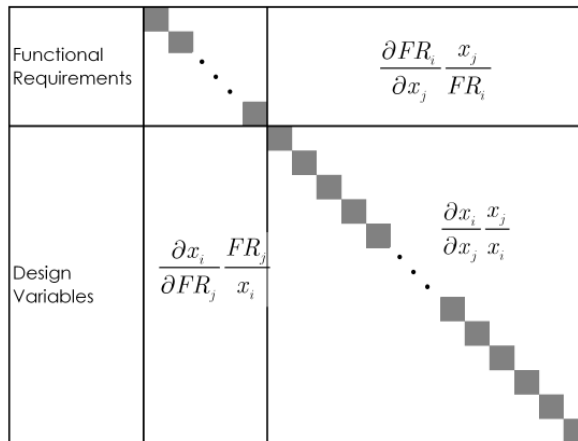

Figure 2.2 sDSM (functional requirements and design variables)

The southwest quadrant of the sDSM is populated by the sensitivities of the design variables to exogenous parameters; the main body of the sDSM

(south-east quadrant) contains the sensitivity of the design variables to other design variables for the particular solution.

Design variables that are insensitive to changes in other design variables and functional requirements are potential platform components. Those that are most sensitive are potential sources of flexibility. In flexible WDS design, the sensitivity of design variables to changing scenarios is much more important than the sensitivity of design variables to other design variables for the particular solution.

Investment decisions are still a major challenge for urban water infrastructures like WDS, which perform in an inevitably dynamic environment. Flexibility generation in system design is an investment problem in which a premium has to be paid for an option that can be exercised later. The investment decision depends on the trade-off between the cost of capturing the options and the expected benefit that may arise from future uncertainties. The estimation of the value of flexibility has three major elements (de Neufville, 2002). These are:

- i) Estimation of the loss associated with the system without flexibility;
- ii) Calculation of the value of the flexible options;
- iii) Identification of the strategies for exploiting the options to permit the best use of the flexibility built into the system.

Shah et al. (2008) delineate some of the attempts and challenges of decision-making under uncertainty. Designers wish to develop engineering solutions that meet their needs both now and in the uncertain future. They therefore try to design solutions that will deliver high value to them in a variety of different possible futures. They also attempt to create designs that allow them (or their agent) to make changes and adjustments to the engineering solution so that they can maximize the value once the future is known. Since they must make design choices in the present on the promise of future benefits, their decisions will be based on their perception of the value of the future benefits as seen at the time of decision.

For large design spaces, the decision-making process requires optimization approaches aimed at optimizing the value of decision variables based on the objective functions, while ensuring the limits described by the constraints. In addition, it requires a specific chosen system as a baseline (usually a non-flexible system) for determining the whole life economic gain. The largest economic gain, when compared to the non-flexible alternative, represents the most flexible system alternatives that deliver high flexibility value.

## **2.5 Water Distribution Systems and Uncertainties**

### ***2.5.1 Uncertainty in WDS Design***

The modelling of water distribution often relies on deterministic approaches to describe the behavior of a system. However, all real-life problems

incorporate uncertainty in one way or another. Two general types of uncertainty exist; these are reducible and irreducible uncertainty.

Reducible uncertainty generally results from a lack of information about some aspect of the problem being analyzed (e.g., the status of some valve in the WDS may not be known simply because that information is lacking). However, once the inspection is done, uncertainty can be reduced. Irreducible uncertainty consists of fluctuations that are essential to the problem being studied. Examples of this type are uncertainties associated with pressure and flow measurements. The uncertainty puts the modeler in the difficult position of trying to predict the future and making decisions based on future developments.

For example, the growth of cities can't be predicted with any precision; it follows that it is also difficult to predict future water demands. Some cities have relatively stagnant water demands, but others experience volatile growth that challenges the engineers who design the water systems. The questions about what the future may look like are difficult to answer—no method exists that can answer them with absolute certainty. Demand projections are only as accurate as the assumptions made and the methods used to predict them (Walski et al., 2003), and designs are based on those deterministic projected values.

The contradiction between the deterministic design approach and natural uncertainty can seriously affect the reliability of the results of modelling. Thus the

design, planning, and management of WDS requires that decisions be made in the presence of various sources of uncertainty (Babayan et al., 2007).

### **2.5.2 WDS Design Under Uncertainty**

The recognition of future uncertainty in both design requirements and the operating environment is the most important issue in WDS planning and management, and this recognition represents a significant shift away from traditional practices that use known values for uncertain future parameters (Hassan and de Neufville, 2006). Some recent studies on WDS under uncertainty and their attempts to cope with those uncertainties are reviewed below.

Babayan et al. (2005) considered the uncertainty associated with water demand when predicting the behavior of a system. Their research focused on designing a water distribution network with minimum cost while meeting the pressure requirements in terms of a given robustness level under uncertain demand. A stochastic WDS design methodology is used to obtain robust and economic solutions for the water distribution network design (robustness of the network is defined as its ability to provide adequate supply to customers despite fluctuations in some or all of the design parameters). The assumptions made in the study are:

- i) Network configuration data (i.e., pipe layout, connectivity, etc.) is known.
- ii) Minimum pressure head constraints at pipe junctions (nodes) are given.

- iii) Diameters of the new pipes (laid down on their own or in parallel with existing pipes) are represented as decision variables.
- iv) Uncertain nodal demands are independent, random variables with given probability distribution functions (PDFs).

Babayan et al. (2007) developed a multi-objective optimization approach to formulate the problem associated with stochastic (i.e. robust) WDS design under uncertain variables (future water consumption and pipe roughness). The problem formulation is based on two parameters—the minimization of cost of the network design/rehabilitation and the probability of network failure due to uncertainty in input parameters. The most uncertain parameters, future water consumption and pipe roughness, are considered as independent variables with pre-specified probability density functions (PDFs). The problem is solved using GAs after converting it to an equivalent, simplified deterministic optimization problem. The methodologies are tested and compared on the well-known problem of reinforcing New York Tunnels, and they show that neglecting uncertainty in the design process may lead to serious under-design of water distribution networks.

Recently, Giustolisi et al. (2009) proposed a procedure for robust design through a multiobjective (minimization of design cost, maximization of WDS robustness) approach that considered nodal demands and pipe roughness as uncertain variables. The research followed a two-step design procedure for

computational efficiency, including a deterministic design (i.e., constrained least-cost design procedure) as the first step and using a deterministically derived initial population in order to solve the robust design problem multi-objectively, implementing the minimization of design costs and the maximization of WDS robustness as objective functions. This study is a great achievement in design of WDS under uncertainties. The methods are used to design systems that satisfy a fixed set of requirements, despite changes occurring in the system's environment. However, the ability to change or react in a timely and cost effective manner is required for the system to deliver high value in an ever-changing world, and flexibility is proposed as a key feature for designing systems in a changing world (Beard, 1982; de Neufville, 2004; Saleh et al., 2001; Schulz et al., 2000).

## **2.6 Reliability Based WDS Optimization**

WDS are often designed to supply adequate amounts of water at each node and with sufficient pressure. However, incidents such as pipe breakage and variation in nodal demand will cause high energy losses in the system that can lead to the failure of delivering the desired flow rate at the required pressure. Despite these facts, the design of WDS usually involves optimization of cost by reducing the size of components or completely eliminating some of the components. These optimization techniques leave the system with insufficient capacity to respond to future eventualities such as demand variability, pipe breaks (usually due to gradual aging), etc., with the required performance level

(Farmani et al., 2005). However, the design of WDS for adequate service with reliability and a safety factor to handle future uncertainties has become a major goal (Babayan et al., 2007) and, in the most recent decade, optimization of WDS has shifted to a design that involves the tradeoff between cost, reliability, and robustness of the design.

The major definition of reliability is not seen as a gap in analyzing WDS as such; rather, the assessment of reliability in a system has been referred to differently by different authors, which has made the term vague due to the vast number of interpretations it has been given over many years. Reliability in WDS mainly refers to the ability of the system to provide an adequate level of service under normal and abnormal conditions (Goulter, 1995). According to Babayan et al. (2005), the reliability of WDS centers on providing consumers with the required quantity of water as often as possible under potential demand uncertainty and pipe failure conditions. It is also defined as the flexibility of the system to respond to component failures through alternative flow pathways (Halhal et al., 1997). Reliability is also usually associated with the probability of the system to operate at an intended performance over a specified period (Farmani et al., 2005). According to Raad et al. (2010), reliability refers to a measure of system performance expressed as the ability of the system to satisfy the demand placed on it and might be quantified as the proportion of time that the system functions as intended (its availability).



Reliability is also measured in terms of connectivity and reachability. Connectivity indicators are used to represent the probability of whether a demand node is connected to the source, and a reachability indicator is used to represent the probability that all nodes are connected to the source (Wagner et al., 1988). Walski et al. (1987) suggested that improving the performance of WDS by analyzing reliability should involve how the users are affected by considering the number of users without the required service or duration of failure occurrences.

According to Tolson and Maier (2004), network capacity reliability is the probability of meeting design constraints (e.g., pressure) under different uncertain parameters (e.g., demand and pipe roughness). The reliability of WDS is primarily studied by considering two types of failure—mechanical failure and hydraulic failure. Details of these types of failures are presented in the following subsections.

### **2.6.1 Hydraulic Failure**

Hydraulic failure mainly occurs due to the reduction in hydraulic capacity of pipes and/or uncertainty of nodal demand. The capacity of pipes largely depends on their roughness coefficient. The roughness of water network pipes varies over time. The cause of the variation is unknown and depends on many factors such as age, environmental condition (temperature, soil type, etc), water and flow characteristics, etc. Similarly, the design of WDS is based on the estimation of demand for both existing and future populations. However, the

predictions are filled with a great deal of uncertainty and could cause hydraulic failure. Design consideration of hydraulic reliability gives the system the ability to perform well under the aforementioned uncertainties. The design of flexible WDS considers many options embedded in the system to deal with eventualities and also equips the system with the ability to change to another alternative system (evolving system) to reduce the hydraulic failure associated with future changes.

### **2.6.2 Mechanical Failure**

Mechanical failure basically refers to the failure of WDS components. This failure scenario usually occurs due to pipe breakage, pump breakage, unavailability of WDS components due to maintenance, or even through externalities like power failure. Pipe breakage usually occurs due to gradual aging; it is a challenge for water engineers to determine the condition of pipes in order to determine if the mechanical failure is caused by pipe breakage. In addition to the condition of pipes, the size of pipes has a considerable effect on the breakage rates. Smaller pipes break more frequently than larger pipes and affect the system's ability to meet its performance goals.

According to Ostfeld (2004), the assessment of the reliability of WDS could be grouped into three major categories: (i) analytical (connectivity or typological) approach, (ii) simulation (hydraulic) approach, and (iii) heuristic (entropy) approach. A summary of the literature discussing these approaches is presented in Table 2.1.

- i) Analytic approach is associated with the probability of the WDS to remain connected physically. It is based on the connectivity and reachability of the components of WDS without considering the hydraulic reliability of the system; it basically depends on the layout configuration of the WDS.
- ii) Simulation approach is based on the hydraulic reliability of the WDS. This refers to the conveyance of the required quality and quantity of water at the required pressure at the appropriate location during a specified time period (Trifunovic, 2012). Simulation reliability analysis method requires hydraulic modelling of the WDS. This method is considered the most popular method in determining the reliability of WDS.
- iii) Heuristic approach is based on the measure of reliability through entropy of WDS. The level of entropy is correlated with the reliability; however it is a challenge for WDS engineers to determine what precisely entropy means in terms of reliability (Trifunovic, 2012).

### **2.6.3 Water Distribution System Reliability Measures**

Reliability measures are used as an indicator of the ability of the WDS to respond to future eventualities and extreme events. Recent works have presented different reliability surrogate measures as indicators, including *flow entropy*, *resilience index*, and *network resilience*. The indicators are usually used to evaluate the critical scenario combining the peak demand, fire flows, scenarios, etc.

Table 2.1 Methods for reliability measurement of WDS

Authors	Approach	Reliability Measure	Methodology
Goulter, (1987)	Analytical approach	General overview/trends	Overview
Jacobs and Goulter, (1988)	Analytical approach	Account of all possible combinations of working/non-working system components	State enumeration, filtering & heuristic procedures
Jacobs and Goulter (1989)	Analytical approach	Based on redundancy of WDS layout	Integer programming combined with manual search
Wagner et al., (1988)	Analytical approach	Connectivity and Reachability	Graph theory algorithms
Su et al., (1987)	Simulation approach	Probability of meeting nodal demands and heads requirements for pipe failure condition	Minimum cut-set
Fujiwara and Ganesharajah, (1993)	Simulation approach	Based on expected served demand (considering insufficient heads and flows at the nodes)	Markov chain approach
Xu and Goulter, (1999)	Simulation approach	Based on the probability of meeting nodal demand at least with a minimum required pressure	first-order reliability-method-based algorithm
Awumah, and Goulter, (1992)	Heuristic approach	Entropy based measures: based on flow and consumption	Tailored maximum entropy flow algorithm for single source
Tanyimboh, and Templeman, (2000)	Heuristic approach	Entropy based measures: flow and consumption	Tailored maximum constrained approach

### 2.6.3.1 Flow Entropy

The concept of entropy was developed by Shannon (1948) based on the statistical approach of information theory to measure the degree of variability in a system. It is sometimes called the measure of randomness or uncertainty. The Shannon entropy function is written as shown in Equation 2.2.

$$\varepsilon = f(p_1, p_2, \dots, p_n) = - \sum_{i=1}^I p_i \ln p_i \quad 2.2$$

where  $\varepsilon$  is the entropy;  $p_i$  is the probability associated with the  $i^{th}$  event/outcome;  $I$  is the number of outcomes; and  $-\ln p_i$  is self-information of a random variable (Shannon, 1948).

The concept of Shannon entropy has been used to measure the reliability of WDS (Awumah, 1992). The method aims to obtain the maximum uniformity of the flow distribution in a system from all supply points to all nodes, and ultimately to minimize the mechanical and hydraulic failures in a WDS. This reliability surrogate measure has been applied for reliability-based design of WDS by a number of researchers, such as Awumah and Goulter (1992) and Tanyimboh and Templeman (1993) and is written as shown in Equation 2.3 and Equation 2.4.

$$\varepsilon_w = \varepsilon_R + \sum_{j=1}^n \frac{Q_j}{Q} \varepsilon_i \quad 2.3$$

$$\varepsilon_w = - \sum_{r \in R} \frac{q_r}{Q} \ln \left( \frac{q_r}{Q} \right) - \frac{1}{Q} \sum_{j=1}^n Q_j \left[ \frac{d_j}{Q_j} \ln \left( \frac{d_j}{Q_j} \right) + \sum_{j \in n_u} \frac{q_{j,u}}{Q_j} \ln \left( \frac{q_{j,u}}{Q_j} \right) \right] \quad 2.4$$

where  $\varepsilon_w$  is the entropy of the WDS;  $\varepsilon_R$  is the entropy of the source;  $\varepsilon_i$  is the entropy of the demand node  $j$ ;  $Q_j$  is the total flow at each node;  $Q$  is the total demand;  $q_r$  is the flow from the source  $r$ ;  $R$  is the number of source points;  $n$  is the number of demand nodes;  $n_u$  is the set of all nodes immediately upstream

from and connected to node  $j$ ; and  $q_{j,u}$  is the flow in the pipe that joins  $j$  with the upstream node  $u$ .

As shown in Equation 2.4, the network entropy  $\varepsilon_w$  depends on the values of inflow and outflow of the WDS and the flow rate of the pipes. A higher value of  $\varepsilon_w$  means a more balanced system that is able to respond to failures in a more effective manner. In addition, looped and redundancy pathway systems increase the distribution and uniformity of flow and in turn maximize the entropy of the system. This reliability measure increases redundancy incidentally, especially if pipe failure is considered (Raad et al., 2010) and maximizes the uniformity of flows in the network.

### **2.6.3.2 Resilience Index**

The resiliency index method was designed to guarantee the availability of water by increasing the hydraulic reliability and availability of WDS. The idea of resiliency index was introduced by Todini (2000) and is a measure of the excess power in the system. It is based on increasing sufficient surplus power in the system, which could be used in case of failures. Todini (2000) used the surplus potential to handle failures as an indicator of the network reliability of the looped WDS. By providing excess power at each node, the system will have the capability to absorb much of the internal power dissipation during a failure event. The total power in the system is described as shown in Equation 2.5.

$$P_{total} = P_{int} + P_{ext} \quad 2.5$$

The total available power in the system depends on the power at the supply point and the additional power introduced into the WDS by pumps (see Equation 2.6).

$$P_{tot} = P_{reservoir} + P_{pump} \quad 2.6$$

$$P_{tot} = \gamma \sum_{r=1}^{N_r} Q_r H_r + \sum_{p=1}^{N_p} P_p \quad 2.7$$

where  $P$  is the power;  $Q_r$  and  $H_r$  are the flow rate and the pressure head at each reservoir and pump, respectively;  $N_r$  and  $N_p$  are the number of reservoirs and pumps in the WDS; and  $\gamma$  is the specific weight of the water.

The available power (energy per unit of time) at each demand node ( $P_{ava}$ ) depends on both the total amount of power supplied to the WDS and the power dissipated internally in the pipes ( $P_{dis}$ ) and it expressed mathematically as shown in Equation 2.8 through Equation 2.11. .

$$P_{ava} = P_{tot} - P_{dis} \quad 2.8$$

$$P_{ava} = \gamma \sum_{j=1}^n Q_j H_{ava,j} \quad 2.9$$

$$P_{dis} = P_{tot} - P_{ava} \quad 2.10$$

$$P_{dis} = P_{tot} - \gamma \sum_{j=1}^n Q_j H_{ava,j} \quad 2.11$$

where  $Q_j$  and  $H_{ava,j}$  are the flow rate and the pressure head at each node and  $n$  is the number of nodes in the WDS.

The resilience index (which indicates the power surplus) of the looped WDS is defined by the normalized power surplus ( $P_{surp}$ ) as shown in Equation 2.12 and Equation 2.13.

$$I_R = \frac{P_{surp}}{P_{max,surp}} \quad 2.12$$

$$P_{max,surp} = P_{tot} - P_{req} = P_{tot} - \gamma \sum_{j=1}^n Q_j H_{req,j} \quad 2.13$$

where  $P_{max,surp}$  is the maximum possible surplus power in the WDS while satisfying the total demand. Thus the resiliency index can be represented as using Equation 2.14 and Equation 2.15.

$$I_R = \frac{P_{ava} - P_{req}}{P_{tot} - P_{req}} \quad 2.14$$

$$I_R = \frac{\gamma \sum_{j=1}^n Q_j (H_{ava,j} - H_{req,j})}{\gamma \sum_{r=1}^{N_r} Q_r H_r + \sum_{p=1}^{N_p} P_p - \gamma \sum_{j=1}^n Q_j H_{req,j}} \quad 2.15$$

The provision of surplus power at each node may not be sufficient for the reliability of WDS. For example, a branched WDS could have excess power head at each node but may not be reliable enough to satisfy the required demand for the intended period—that is, its resiliency may not represent the redundancy of the pipes at the nodes (the case of branched systems). Thus, surplus power is necessary but not sufficient for reliability (Prasad, 2004), suggesting the need for network reliability, which considers these issues.



### 2.6.3.3 Network Resilience

The concept of network resilience was developed from the resiliency index introduced by Prasad (2004). This approach simultaneously considers the reliability index (surplus power at demand nodes) and the reliability of loops in the network. Network resilience is based on the principle that reliable loop networks should have similar pipe sizes (Raad et al., 2010). This method penalizes the abrupt change in pipe size within the loop network. Considering nodes supplied by a number of pipes, a high reliability system is represented by a node that has pipes with the least variation in size. For  $m$  pipes joining at node  $j$ , the similarity of the pipes at node  $j$  is defined as shown in Equation 2.16.

$$S_j = \frac{\sum_{j=1}^m D_j}{m * \max[D_1, D_1, \dots, D_N]} \quad 2.16$$

The robustness of the system could then be guaranteed by increasing the network; furthermore, a WDS designed based on network resiliency will be better able to cope with pipe failures than a system designed based on the resiliency index. The excess (surplus) power ( $P_{surp,j}$ ) at each node may be determined using Equation 2.17.

$$P_{surp,j} = \gamma Q_j (H_{ava,j} - H_{req,j}) \quad 2.17$$

The combined resiliency (both surplus power and pipe uniformity at the nodes) is represented by the weighted surplus power (see Equation 2.18).

$$R = \sum_{j=1}^n S_j P_{surp,j} = \sum_{j=1}^n S_j * Q_j (H_{ava,j} - H_{req,j}) \quad 2.18$$

The resiliency of the whole network is then represented by the normalized combined resiliency (normalized by the maximum) (see Equation 2.19). In addition, the energy supplied to the WDS (i.e., the pump energy), which was not considered in the network resiliency is then added (Prasad, 2004).

$$I_N = \frac{\sum_{j=1}^n S_j * Q_j (H_{ava,j} - H_{req,j})}{\gamma \sum_{r=1}^{N_r} Q_r H_r + \sum_{p=1}^{N_p} P_p - \gamma \sum_{j=1}^n Q_j H_{req,j}} \quad 2.19$$

#### 2.6.4 Discussion

Reliability in a WDS is not sufficient to cope with the future change requirements that those systems will face. Most optimization practices in the planning of WDS design the systems on the basis of cost. Some consider the reliability of the system using reliability surrogate measures such as flow entropy, resiliency index, and network resilience. These approaches increase the system's capacity to perform under severe conditions and are more favorable to robust systems than to flexible systems, as they maintain the uniformity of flow (entropy) or surplus power at the nodes (resiliency index). The entropy method increases the uniformity of flow depending on the inflow and outflow of the network and pipe flows, and the resiliency index aims to obtain an excess power at each node, allowing the system to absorb internal power dissipation during a failure. The reliability measures do not consider the different states and periods

of future uncertain parameters and do not offer the capability of a system to change when there is a change requirement. In addition, they do not provide the opportunity to embed different options into the system's design at different stages in order to improve the performance of the system. However, flexible systems are an alternative that can provide an adequate amount of water at each node and sufficient pressure for different future states and times of design (scenarios). Therefore, this study develops a flexible WDS design methodology that maximizes the ability of a system to handle a wide range of uncertainties. This methodology is presented in the next chapter.

### **3 Framework for Design of Flexible Water Distribution System**

#### **3.1 Introduction**

This chapter addresses the main objective of this research, that is the development of a design framework that can generate optimal water distribution systems (WDS) that are adaptable and flexible under future global change pressures. The framework facilitates the flexible design of WDS, which are able to cope with future changes and uncertainties in a cost effective and performance efficient manner. The framework is based on optimization techniques and explores the flexibility of the WDS under different possible future uncertainties. The proposed framework involves four major steps such as uncertainty description, identifying suite of flexibility options, flexibility generation, and flexibility assessment and decision-making under uncertainty (see Figure 3.1).

This chapter presents the development of the major steps of the framework as well as their interactions. The chapter also addresses, as part of the development of the framework, the specific research objective to develop performance metrics that will allow an assessment of the flexibility of the WDS. The chapter concludes by explaining how to interpret the results of the framework and how to apply it in decision-making processes. Flexibility generation is the major component of the framework that involve GA-based

flexibility optimization model for centralized WDS, and clustering tool for decentralized WDS. The two components will be explained in detail in Chapter 4 and Chapter 6 respectively. The application of the framework for real world case studies is presented in Chapters 5 and 7.

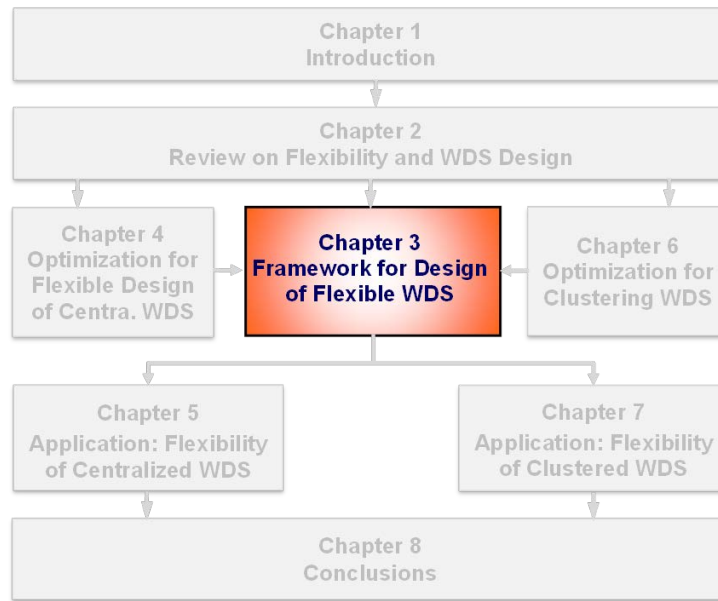

Figure 3.1 The interconnection of Chapter 3 with other chapters

### 3.2 Framework for Design of Flexibility Water Distribution System

WDS design principles should comprehensively address “delivering flexibility” in a system (Ramirez, 2002). According to Eckart et al. (2011), flexibility is defined as “the ability of water systems, to use their active capacity to act, to respond on relevant alterations in a performance-efficient, timely and cost-effective way.” The planning and design of WDS requires decision criteria for flexibility that allows the systems to cope with uncertainty. Designers attempt to

develop solutions that will satisfy both current and future requirements, despite the fact that the future is uncertain.

In order to design flexible WDS that have the capability to cope with future alterations and to enhance the ability of a system to utilize the positive side of uncertainty, the following basic questions should be addressed: flexibility to what and when?; what type of flexibility is required and where is it embedded?; and how much flexibility is required? (Hocke and Heinzl, 2006); Shah et al., 2008; Cardin and Neufville, 2008). These questions thus frame the flexible WDS design framework proposed in this work, as shown in Figure 3.2. The proposed design framework involves four major steps, outlined below and then described in the following section:

- i) Uncertainty description: when is flexibility required and for what?
- ii) Identifying suite of flexibility options: what flexibility is required and where is it embedded?
- iii) Flexibility generation: the level of flexibility required?
- iv) Flexibility assessment and decision-making under uncertainty: which alternative should be selected?

In order to determine when flexibility is required, the first step is comprised of uncertainty description and scenario development. This step defines the range of major uncertainties to be treated.

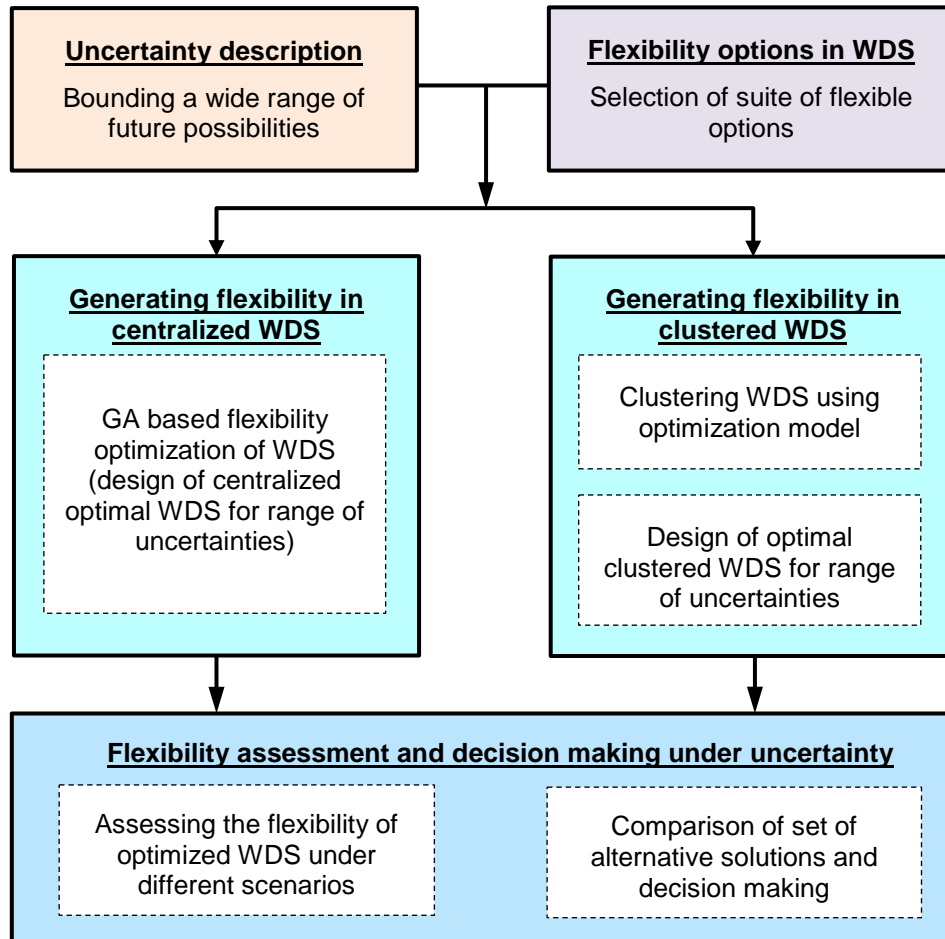

Figure 3.2 Flexible WDS design framework

The second step is the identification of flexibility options. This step defines the sets of options for WDS, options that are most likely to offer the best lifetime flexibility. The third step involves flexibility generation into WDS by embedding the ability of the system to change when change is required. This involves two different alternatives. One is for centralized WDS and the other is for decentralized/clustered WDS. In designing flexible centralized WDS, GA based flexibility optimization is performed to embed stepwise expansion/growth of the centralized WDS. In designing decentralized WDS, a unique clustering technique is applied to allow implementation of flexible clusters. The flexibility generation for

both centralized and clustered WDS described here offers an opportunity to embed suites of flexibility options into WDS so that it adapt to future change. Since options don't guarantee flexibility, this process may require considering various options. If an option does not offer lifetime flexibility, a different option could be embedded into the system with that lifetime value added with respect to the rigid system (usually with robust systems). In addition depending on the nature of the problem the appropriate optimization model for centralized or for decentralized/clustered WDS has to be selected. The last step is a flexibility assessment and decision-making process for determining the best system alternative. A post-optimization analysis is performed to assess the flexibility of different alternatives and compare their flexibility under a wide range of uncertainties. To support the decision about which flexible alternatives should be selected, the *minimax* regret rule is applied. The decision is based on current knowledge about the future. However, flexibility affords decision makers with the ability to make different decisions at different times when required.

### **3.2.1 Uncertainty Description**

#### **3.2.1.1 Uncertainty in Design of WDS**

Water engineers and planners often face challenges in making a decision under uncertainty. The design of water distribution models is often developed as a simplified version of a real network by considering deterministic and precise input parameters. For example, in the case of pipe roughness, the complexity of understanding deterioration over time and the associated cost and time involved



in estimating the actual value make it difficult to determine the friction characteristics of the pipe after a certain age. The uncertainties surrounding these systems can clearly be complex.

For simplification, Shibu and Reddy (2011) separated uncertainty into three major groups: (i) uncertainties associated with measurement and prediction; (ii) uncertainties associated with information gaps/lack of knowledge; and (iii) uncertainties associated with simplification of the real problem. According to Peng and Zhao (2009), the uncertainties can also be divided into bounded and unbounded uncertainties. Details of these categorical typologies are shown in Figure 3.3 (Peng and Zhao, 2009).

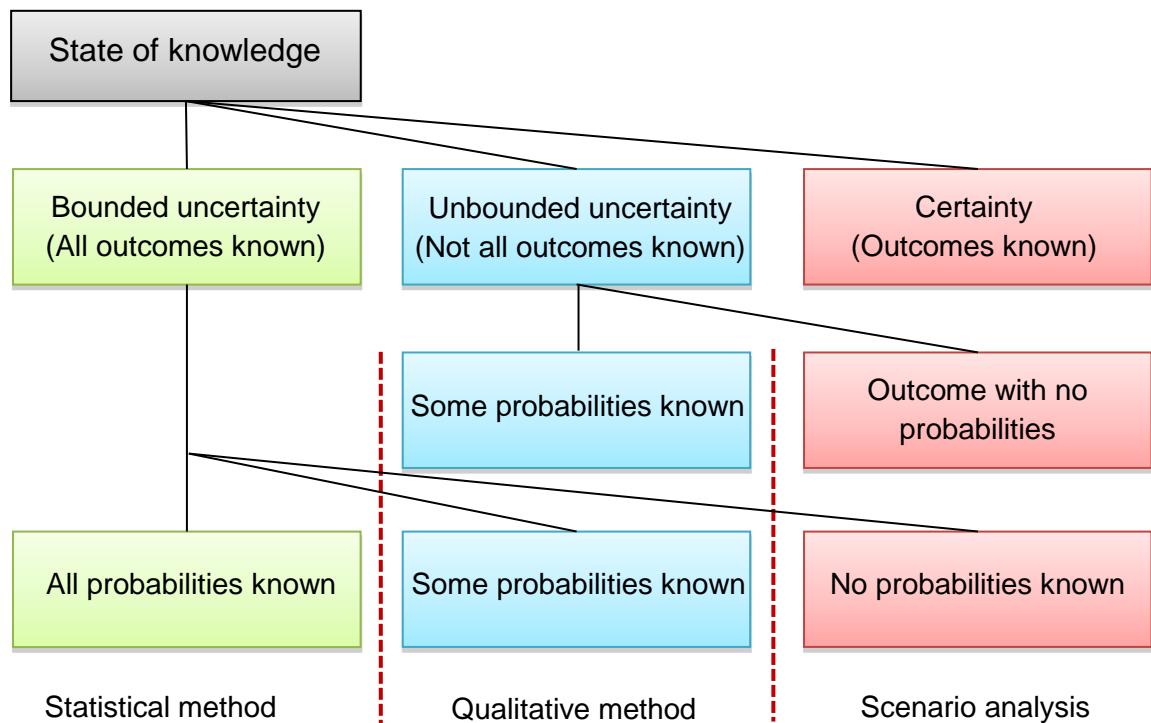

Figure 3.3 Typology of uncertainties

Various methods have been used to describe uncertain information based on their typology. For example, the last section in Figure 3.3 illustrates that scenario analysis could be used to describe future outcomes with unknown probability. Other methods such as Monte Carlo Simulation (Kuczera and Parent, 1998), Latin Hypercube (McKay et al., 1979), and First Order Second Moment (FOSM) (Dettinger and Wilson, 1981) are used to describe uncertainties. The selection of a method for uncertainty description generally relates to the type of uncertainty involved. Monte Carlo Simulation is a versatile method, which is based on a large number of model simulations (Nilchiani and Hastings, 2007). It consists of performing a large number of deterministic analyses for random realization of the problem. Latin Hypercube sampling is a particular Monte Carlo sampling technique. The difference between Latin Hypercube sampling and Monte Carlo sampling is the way in which the uncertain variables are sampled. Monte Carlo technique uses random sampling, whereas the Latin Hypercube sampling technique generates stochastic variables in a random yet constrained way (McKay et al., 1979). The First Order Second Moment method was introduced by Dettinger and Wilson (1981) and has been widely used to analyze uncertainties. According to Maskey and Guinot (2003), this method uses linearization of a function that relates the input parameters to the output variable. Scenario planning is a 'what if' approach used to describe possible future changes and uncertainties (Eppen, 1989). It describes various future states as members of families of discrete possibilities. This particular technique is widely used when it is difficult to associate probabilities with uncertain parameters.

Again, the choice of a particular method depends on the information available—none of the methods give precise results (Nilchiani, 2005).

Uncertainty in WDS involves spatial and temporal variations of community growth, water demand, pipe breakage, friction characteristics of pipes, public perception, climate change, and a number of other factors. The uncertainty associated with future water demand is one of the major factors that impact the design of WDS. Because of its huge impact on the basic condition of WDS, this study considered the future spatial and temporal variation of water demand in the design of flexible WDS. One of the most convenient ways of representing demand uncertainties in the design of a WDS is through scenario planning (Arboleda and Abraham, 2006). Scenario approach is use for the description of the uncertainty associated with spatial and temporal variation of demand because of two main reasons. The first reason is that the probability associated with the variation of demand is unknown and scenario approach is appropriate method for uncertainty parameters with unknown probability. The second reason is that scenario approach describe the uncertainties using scenario nodes (where each node represent the future state and stage) and hence those scenario nodes allow decision making for a stepwise evolution of WDS to adapt to different future conditions. As a general rule, scenario-based uncertainty modelling methods are relatively simple and can be applied for discrete future states.

### 3.2.1.2 Scenario Development

The focus of a scenario is not to forecast future change or to characterize the uncertainties associated with it, but rather the focus is on bounding the uncertainties (Schoemaker, 1991). In the design of WDS, bounds or ranges of possible future water demand patterns are considered either by presenting best and worst cases, or by using scenarios that may include the base condition (based on future projections and previous studies) and the lower and higher extreme cases. Figure 3.4 (a) illustrates one-dimensional planning based on the assumption that the future conditions are known, and Figure 3.4 (b) illustrates scenario planning based on future conditions associated with uncertainties.

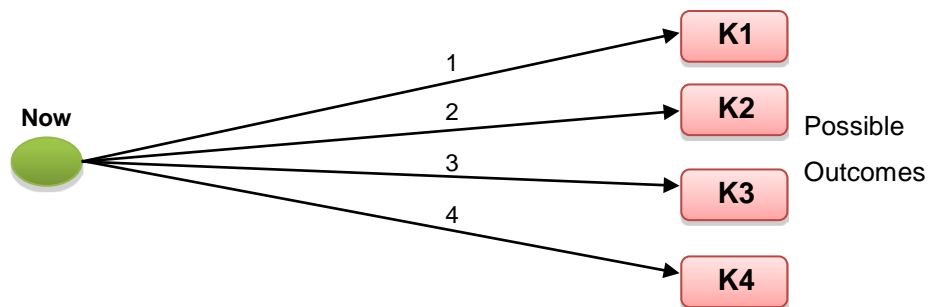

(a) One dimensional planning for known future condition

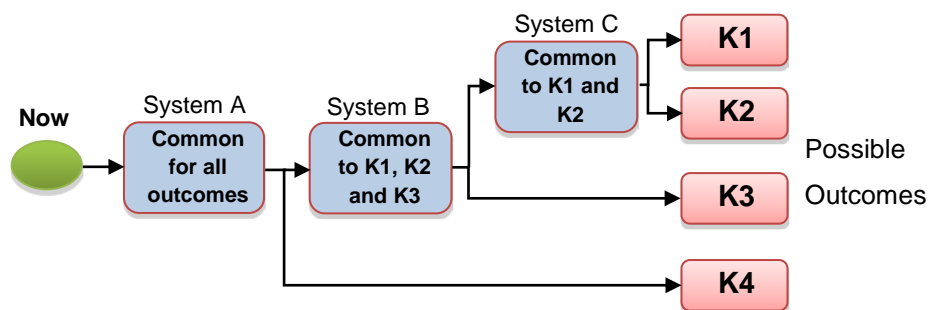

(b) Scenario planning for unknown future

Figure 3.4 Planning options: (a) one dimensional (b) scenario planning

The one-dimensional planning approach is suitable when the future is well defined and the range of uncertainty is limited; scenario planning is suitable if the future is coupled with a wide range of uncertainties (Kazi et al., 2009). Figure 3.4 (a) illustrates that if the future condition is known, a single trajectory can be followed. For the known outcomes K1, K2, K3, and K4 an independent trajectory/decision path 1, 2, 3, and 4 can be followed respectively. Because the future outcomes are coupled with uncertainties, the successive decision paths should involve possible combinations of outcomes. Figure 3.4 (b) illustrates scenario planning that allows a combination of different possible outcomes and involves successive decision steps (paths) to different possible futures. For example, the unknown future outcomes K1, K2, and K3 in Figure 3.4 (b) could represent possible future water demand in WDS. Thus, from the figure, the adaptation to the future demand K1, K2 requires both systems B and C, whereas system B only is required to cope with future demand K3. This means that system B is common for the future demand K1, K2, and K3. Common elements of WDS allow a stepwise change to different possible future demand scenarios. Due to its ability to incorporate possible future outcomes, the scenario approach offers greater flexibility in responding to a changing environment (Marra and Thomure, 2009). The selection of the scenario in WDS is based on the experience of the designer or decision maker and their knowledge of the particular system being optimized (Arbues et al., 2003). For example, temporal and spatial variation of water demand is considered as the only uncertain parameter in the design of a WDS. A range of limited possible future states can

represent the future distribution of nodal demand in a simple, tractable manner using the scenario tree shown in Figure 3.5.

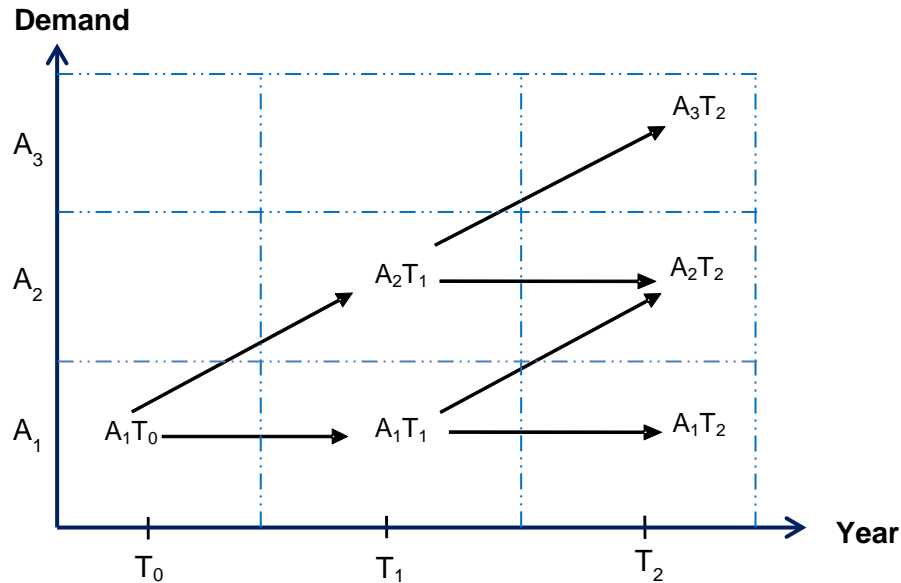

Figure 3.5 A scenario tree (future water demand A at different time T)

The nodes in Figure 3.5 represent states of the nature (demand Q) at a particular point in time (T). For increasing water demand scenario varying from  $Q_1$  at time  $T_0$ , to  $Q_2$  at time  $T_1$  and  $Q_3$  at time  $T_2$ , the scenario tree is developed. This scenario tree involves four paths shown in Figure 3.5. The scenario paths describe the possible future states that the design of the WDS needs to consider.

### 3.2.2 Flexibility Options in WDS

Flexibility options in WDS are the sets of options in a system that most likely offer better lifetime flexibility in the uncertain environment (de Neufville, 2001). Identification of the flexible options in WDS is one of the most important

and challenging steps in designing for flexibility. According to de Neufville (2002), flexibility options are described as either flexibility “in” or “on” a system. Flexibility “in” a system is a technical aspect of the design that enables the system to adapt to its environment, while flexibility “on” a system relates to management decisions without altering its technical components, such as investment deferral (de Neufville, 2002). In conventional design of WDS, the issue of embedding flexible options in the system is not well known. However most of the management aspect of flexibility (investment deferral, expansion) has been considered during the planning stages informally. To identifying what flexibility is required and to help the selection of suites of options that are expected to deliver better flexibility, the options are categorized into three major groups: system design options, system management options, and system element options. In order to deliver better flexibility, options from one category could be coupled with other category. A more detailed discussion of the options is presented below.

### **3.2.2.1 System Design Options**

System design options are technical design options which allow a designer to modify a system to adapt to the future change requirement. These include platform design, stage design, and cluster design.

A platform design approach is utilized where a base system can accommodate a variety of different future alternative solutions. Suh (2005) described the concept of platform design as the generation of 'system families,'

where some elements are common to all system alternatives. Platform design in WDS involves backbone elements (some pipes, reservoirs) which remain in the system for all discrete stages of development. The commonality provides flexibility to the system by creating an opportunity to add new components into a platform element (de Weck et al., 2005). For main pipes in a WDS, parallel pipes could allow stepwise increment/expansion of the platform component. The flexibility of a platform system depends on the developer's ability to choose the optimal extent of communality between different possible alternative solutions that can be used at the later stages depending on how uncertainty unfolds (Kalligeros, K. 2006) and the optimal cost associated with stepwise evolution of the system over time.

Staged deployment is one of the options for creating flexible WDS. It allows incorporating alternative solutions at different decision points (Huang, 2012). Since the uncertain parameters are observed through time, a stage analysis reduces the range of uncertainty to be treated during each decision period, thus reducing the risks associated with decisions. Furthermore, this approach represents an economic opportunity in that it minimizes the initial deployment costs by deploying an affordable system and pushing the expenditures toward the future as much as possible or by investing a premium cost at the earliest stages for an option that can be exercised later.



One important system design principle is cluster/decentralized system design. A generic description of how the principle of system clustering contributes to flexibility is offered by Fricke and Schulz (2005). A cluster system provides semi-centrality or decentrality where a high degree of an autonomous system could be developed to handle future change (Kluge and Libbe, 2006). A semi-centralized or decentralized structure facilitates the allocation of resources and attributes them to the locations of the system that are most suitable for change (Fricke and Schulz, 2005). To facilitate the gradual development of the WDS through time, this option needs to be coupled with staged design options. For example, a centralized WDS can be designed in such a way that it can be changed into decentralized sub systems with little effort and without affecting the performance of the entire system This may consist of strategically locating flow and pressure valves, connecting alternative water sources to the system when it is required and decoupling from the system when it is not required, etc. The gradual stepwise development of semi-central or decentralized cluster systems enables the expansion or deferral of WDS development corresponding with spatial growth. Hence a cluster approach offers WDS flexibility against the uncertainties of spatial growth, whereas centralized WDS are usually large and complex system that do not adapt easily to a changing environment.

### **3.2.2.2 System Management Option**

System management options are options that increase the ability of planners and decision makers to implement different management decisions at

different times of an operation. Some of these options in planning WDS include investment deferral and multistage deployment. An investment deferral option allows decisions to be delayed or rescheduled depending on how the future unfolds. The multistage deployment option allows decision makers to make flexible decisions along the design horizon. The implementation of these management options should be evaluated with respect to the range of uncertainties they can handle and the flexibility they can offer.

### **3.2.2.3 System Element Options**

System element options are component options comprised of flexible elements or a combination of elements within the architecture of WDS that deliver better lifetime value under uncertainty. One major challenge for flexibility in WDS is the identification of potential flexibility locations for flexible elements in the WDS. This is because identification of WDS element options demands a rigorous understanding of the components in the system and how they respond to different future pressures and variability. Element options are specific to the system under consideration, and there are no general principles for the development of element options in systems. Nevertheless, several disciplines have attempted to identify the technical aspects of flexibility for their respective systems, though not in the design of WDS. In WDS development, placing a sufficient number of valves in key locations from the beginning despite imposing a premium cost could be beneficial (Armand, 2010). This could reduce the effort required to insert a new valve into existing WDS in operation (sometimes this is

expensive or even impossible). In addition, valves give the option to decouple part of the WDS if required (e.g. during maintenance, or in case decentralization of some part of the centralized network is required). Similarly, the orientation, size, and operation of other WDS components (pipes, pumps, tanks, etc.) and their combination could offer flexibility value. Pipes can be placed in the system so that they can be changed through time when change is required. For example, considering the expansion of WDS as an uncertain parameter, some pipes in the system will be more highly affected by the future growth of the network than others. Those pipes could be built large enough to absorb future uncertain changes (robust approach) or the location of those pipes could be treated differently so that the system can trace the future growth by changing them through time. This includes embedding smaller pipes in to the system at the beginning and expanding the system by adding parallel pipes to trace the future urban growth more closely.

In order to deliver better flexibility, options from one category could be combined with other categories. Figure 3.6 illustrates an example of a combination of different options that could be implemented at different stages of the design for a spatially and temporally-growing water demand scenario shown in Figure 3.5. The options are (i) a platform design option, involving the ability of the system to change to a different system, (ii) a staged design option, which offers flexibility to decision-making at different times, and (iii) a clustered design

using valves to allow decoupling of part of the components from the system, which are considered in the design at different times.

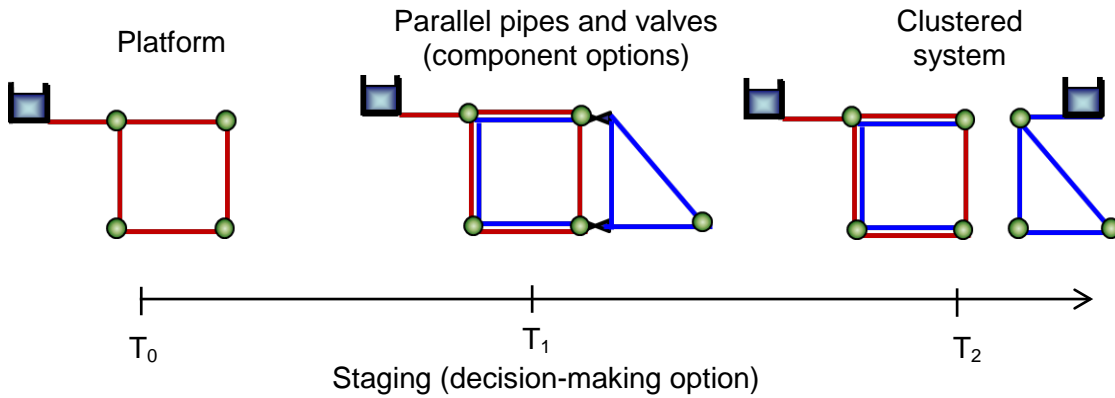

Figure 3.6 Different WDS options

Figure 3.6 illustrates that the platform option is a backbone system and performs for all stages that allow expansion by laying parallel pipes. The clusters are developed by decoupling part of the system (at time  $T_2$ ) using element options (such as valves) emended at time  $T_1$ . In addition, the expansion of the system from one system (with five pipes) to two autonomous systems (with twelve pipes) involves stage wise decision options that follow the future requirements. Selection of options is an iterative process that depends on the flexibility that a given option delivers. The generation and analysis of flexibility is discussed in the next subsection.

### 3.2.3 Generating Flexibility

In a system design, generating flexibility is an investment problem for which a premium must be paid to secure an option that can be exercised later (de Neufville, 2002; Schulz et al., 2000). According to Schluchtermann (1995), the level of flexibility intended for the system is key for the planning of flexibility. One of the most important principles in dealing with flexibility is designing the system “*as rigid as possible and (only) as flexible as necessary*” (Eversheim and Schaeffer, 1980). Flexibility is considered as an optimization task. It can range from totally inflexible to fully, or excessively, flexible and is considered an optimization problem. On the one hand, excessive flexibility is problematic because it generates unnecessary costs for the development of the system (a large effort to adapt) and negative consequences such as disturbances in the system’s performance. On the other hand, too little flexibility could cause problems in adapting to uncertain future drivers because of the specialization (rigidity) of the system (Tsegaye et al., 2011). Thus, both extremes have to be avoided, and an optimum of flexibility has to be developed (de Neufville, 2000). Figure 3.7 illustrates the levels of flexibility ranging from non-flexible (rigid) system to systems with excessive flexibility and the associated cost (Schulz et al., 2000).

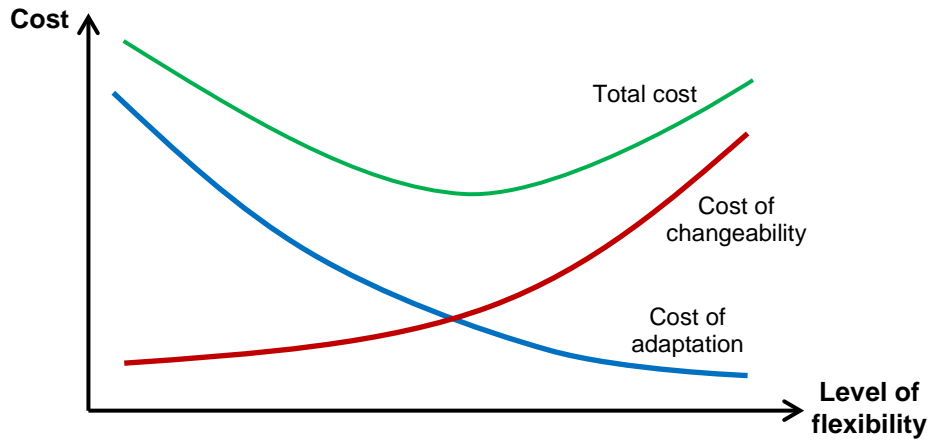

Figure 3.7 Typical relationship between level of flexibility and total cost

Figure 3.7 shows the possible range one can choose in designing WDS. It is assumed that an optimum level that reduces the effort to adapt to future change lies between excessive flexibility and non-flexible system (de Neufville, 2000). When we embed more and more flexible options into the WDS, the changeability of the system increases; however, enhancing changeability in a system is an investment problem for which a premium has to be paid (Schulz et al., 2000). Based on the expected future uncertainties, different combinations of options could be embedded into WDS to offer various levels of flexibility. Excessive flexibility in WDS is achieved by designing a small system capacity with high changeability, whereas rigid and insensitive systems can be achieved by designing large systems. These two systems require different levels of initial investment and adaptation. Figure 3.8 shows the relation between investment and adaptation for small changeable and large rigid WDS.

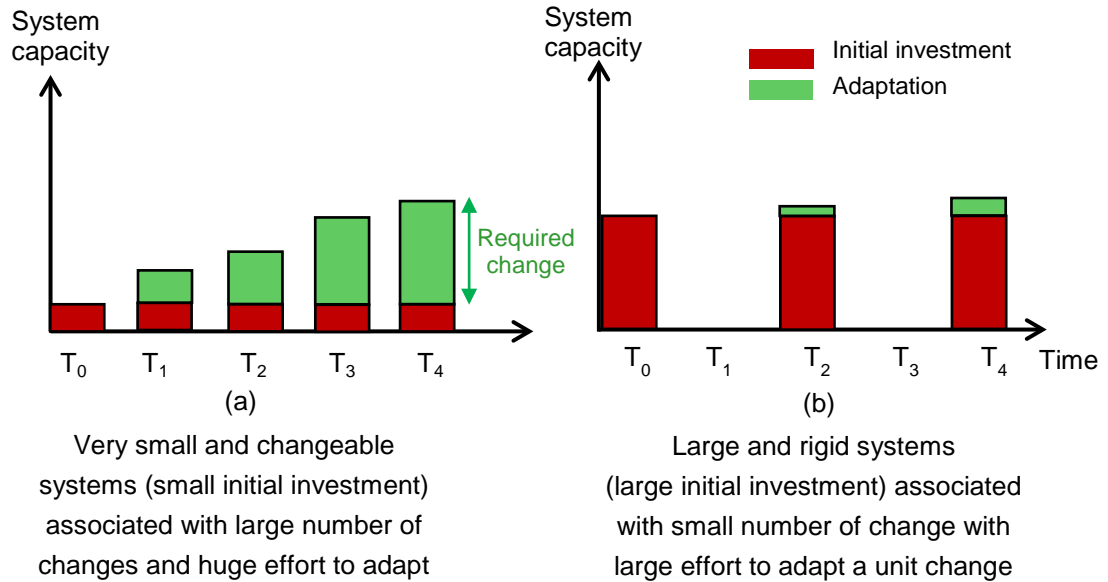

Figure 3.8 Initial investment and required adaptation

Figure 3.8 (a) illustrates that very small and changeable WDS require small initial investments for which huge effort is needed for each additional unit capacity improvement of the system. In addition, it requires a large capability to change when change is required, thus incurring additional effort associated with embedding an option that allows for ease of change in the future. As a result, enhancing changeability in a WDS with a large premium cost associated with adaptation makes it more difficult for those systems to cope with future change (Schulz et al., 2000). As shown in Figure 3.8 (b), unlike systems with excessive flexibility, rigid/robust systems require a huge initial cost of investment. These systems are insensitive to changing environments and are difficult to change when there is a change requirement (de Neufville, 2000). Large investment coupled with a large change effort makes these systems more rigid to react to future change and uncertainty.

The trade-off between the two extremes of excessive and rigid flexibility can be explored using an optimization process that considers both investment and adaptation to different future conditions. In recent decades, the focus of optimization for WDS has shifted from the use of traditional optimization methods, such as linear programming (Alperovits and Shamir, 1977; Kessler and Shamir, 1989) and nonlinear programming (Watanatada, 1973; Lansey and Mays, 1989; Karatzas and Funder, 1996;) to the use of heuristics derived from nature (HDN) such as genetic algorithms (GA) (Simpson et al., 1994), simulated annealing (SA) (Kirkpatrick, 1983) and more recently, ant colony optimization (ACO) (Maier et al., 2003; Simpson et al., 1994; Zecchin, et al., 2007). These optimization techniques encourage the implementation of different objectives with a range of constraints in planning and design of WDS.

According to Dijk et al. (2008), the hydraulic simulation of a WDS within a pressurized, looped pipe network is a complex task, which effectively means solving a system of non-linear equations. The discrete nature of the WDS optimization problem—and the size of the solution space—also makes the optimization process more difficult for conventional optimization techniques to find the optimum solution. Because of its ability to deal with nonlinear complex optimization, GA has become the preferred WDS optimization technique for many researchers and practitioners, including Simpson et al. (1994). According to Huang (2012), GA performs better in designing flexible WDS under uncertainty. Designing for flexibility requires a number of stages and states of



future conditions to be represented by discrete decision nodes (along with a scenario tree). GA optimization techniques can handle discrete decision variables and is a preferred optimization technique for flexibility.

In this study two approaches to flexible optimization have been considered. These are (i) designing centralized system that is sufficiently flexible to the future change and uncertainties, and (ii) enhancing flexibility through decentralization/clustering WDS that facilitates the gradual development of the system through time. The first approach requires the development of optimization algorithms that will cover a wide range of uncertainties. This study develops a unique GA based flexibility optimization (GAFO) model to embed flexibility into centralized WDS (see Chapter 4). The latter requires a clustering techniques and optimization tool that allow partitioning the WDS in to clusters and developing adaptive system. Chapter 6 presents the development of an optimization based clustering tool to allow implementation of flexible decentralized WDS in emerging areas. Depending on the nature of the problem the appropriate optimization model for centralized or for decentralized/clustered WDS has to be selected. This subsection discuss briefly the GAFO and cluster optimization models. The GAFO model is applied to real case-study in Chapter 5 and the clustering method is applied to real case-study in Chapter 7.

### **3.2.3.1 Centralized Flexible WDS**

In optimization of flexible centralized WDS small incremental changes in pipes are utilized to increase the capacity of the WDS and to accommodate a variety of different future changes. This is done by adding parallel pipes to the main component when future growth requires either spatial expansion or a capacity increase. This study develops GAFO model to explore the least costly centralized WDS alternatives that span across a wide range of uncertainties. The model is coded in C++ programming language. This tool differs from previous works which have applied GA in two major aspects: (i) GAFO allows flexibility to be embedded into a WDS design as the optimization is performed against all possible future scenarios. It considers an objective function that involves all possible future scenarios and develops a system's ability to adapt to different future condition; (ii) GAFO is based on staged decision-making which allows stepwise evolution of the WDS over time. GAFO's objective function involves minimization of the cost related to investment and the adaptation to future possible conditions. The optimization embeds flexibility into the system by maximizing the ability of the system to follow different trajectories based on future conditions. Depending on the number of decision points and alternative options embedded in a WDS, a number of subsequent optimal system alternatives—which could span over a wide range of uncertainties—are generated. Considering scenario path illustrated in Figure 3.5 and using parallel pipe for step wise growth of the centralized WDS, an example solution space as shown in

Figure 3.9 could be generated. This solution space follows the same pattern as the scenario paths.

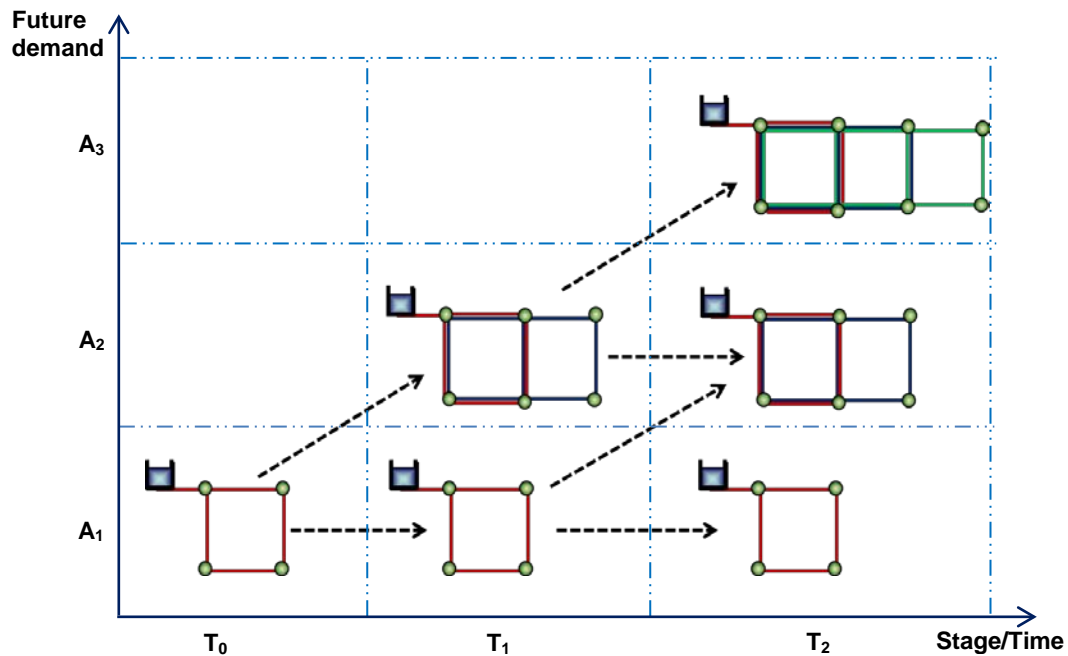

Figure 3.9 Centralized WDS spanning over range of uncertainties

The flexibility-based centralized WDS optimization approach develops a system designed to span a wide range of future conditions, as shown in Figure 3.9. The optimal design explores the least cost solution for both the initial investment and the change requirements for different alternatives at different stages. In addition, different design alternatives could be developed using the same approach, and comparison between alternatives is performed with respect to their ability to cope with future changes. An assessment method for the capability of the WDS alternatives to perform in an uncertain environment is presented in the subsection 3.2.4.

### **3.2.3.2 Clustered Flexible WDS**

Recent studies have shown that clustered/decentralized approach to WDS design allows gradual development of the systems and provide sufficient flexibility to address changing global pressures with time (PSGS 2010; Bieker et al., 2010). This research has developed an optimization method that divides an urban area into clusters to allow for the provision of flexible, modular decentralized urban water systems (see chapter 6).

The optimization involves Euclidean norm minimization and K-mean algorithm. The WDS in each homogeneous cluster is optimized using GA optimization model for a range of uncertainties. The modular diversity of these clusters exponentially increases the amount of possible configurations that can be achieved for WDS from a given set of inputs. For example considering a scenario path illustrated in Figure 3.5 with three future demand states (A1, A2 and A3) in three stages ( $T_0$ ,  $T_1$  and  $T_2$ ), a set of clustered optimized WDS solutions that span a wide range of uncertainties could be developed using clustering and optimization technique. Figure 3.10 shows an example clustered WDS that grows over time.

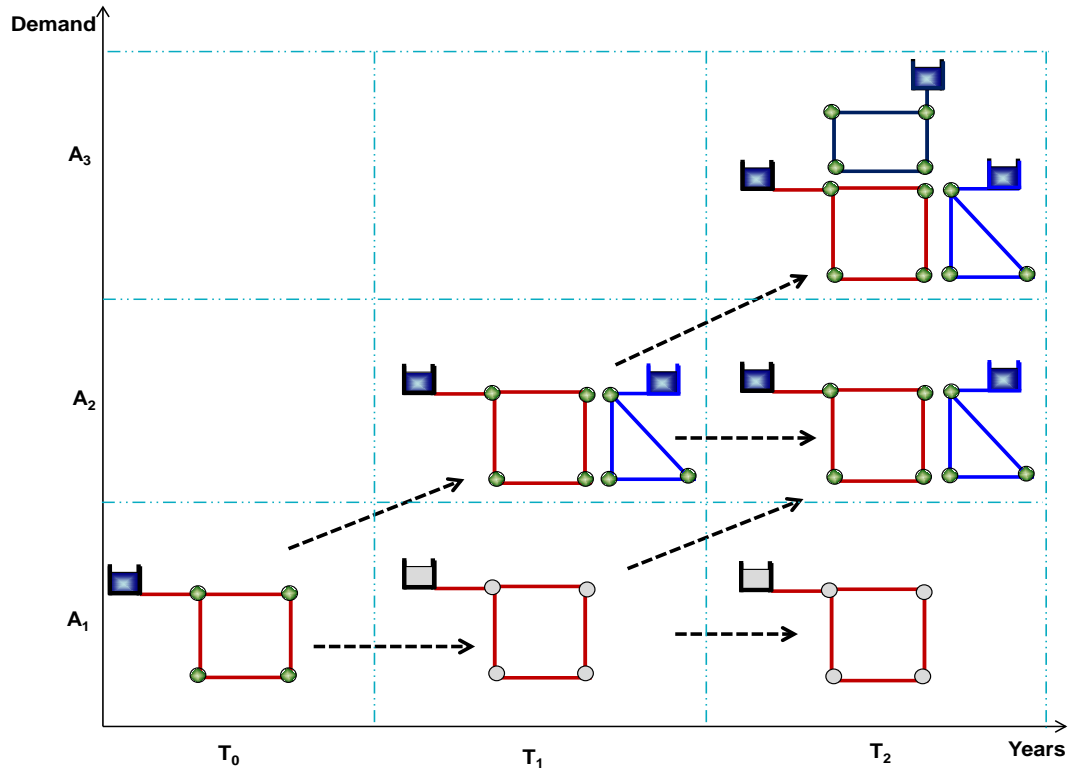

Figure 3.10 Clustered WDS spanning over range of uncertainties

The clustered WDS in Figure 3.10 are designed to span a wide range of uncertainties and to respond and react to the future change in cost effective manner. Different options could also be embedded at different time (i.e. decoupling valves) to enhance flexibility.

Once the flexibility based optimization is performed, the decision-making process is followed to assess the flexibility of different alternatives and to choose the most flexible one. Since the design of flexible WDS considers ranges of possible solutions that perform in unknown future conditions, the choice between flexible WDS alternatives is made using the principles of decision-making under

uncertainty (Finne, 1998, Khu and Keedwell 2005). The details of the decision-making process are discussed in the following subsections.

### **3.2.4 Flexibility Assessment and Decision Making Under Uncertainty**

In this study, a two-stage decision making process is proposed. The first stage is a flexibility assessment of optimized WDS alternative under possible scenarios to determine their ability to respond and adapt to the future. The second stage is comparison and selection of WDS alternative that perform better under wide range of uncertainties.

#### **3.2.4.1 Flexibility Assessment**

A post optimization analysis is performed to evaluate the flexibility of different optimal flexible WDS. In order to analyze different flexible alternatives, four key measurements are induced from the definition of flexibility: “the ability of water systems, to use their active capacity to act, to respond on relevant alterations in a performance-efficient, timely and cost-effective way” (Eckart et al., 2010). These measurements are *capability to respond*, *capability to react*, *performance*, and *duration of change*.

*Capability to respond* ( $C_{rs}$ ) is the embedded capability of the WDS to absorb specific future alterations. This flexibility dimension indicates the intended degree of change that embedded options allow for the system to cope with future changes.  $C_{rs}$  depends on the range of uncertainty that the system is designed to

handle and the effort (cost) required to handle the specified range of uncertainties. In contrast, *capability to react* ( $C_{ra}$ ) is the capability of the WDS to react to unknown future alterations. This dimension indicates the nature and degree of change (in response to unknown future alterations) that the system is able to adapt to, beyond what it was designed for. This capability depends on the range of uncertainty to which the system is required to react and the effort (cost) required to adapt to those unknown uncertainties.

*Performance* ( $P_s$ ) is an indicator used to measure the ability of the WDS to perform better under future alterations. In design of WDS the performance requirements are design constraints that have to be satisfied. According to Mays (2000), the main constraint is supplying the desired water demand with adequate pressure head at withdrawal nodes. Thus, in this research the design of WDS is based on meeting a certain minimum pressure head and is not used as comparison criteria for flexibility of WDS.

*The Duration of the change* ( $t_d$ ) process is the period which is required to adapt the WDS to new requirements. Usually future alterations associated with WDS occur slowly, and this criterion could be ignored in measuring the flexibility of WDS. Thus as part of the development of the framework this chapter develops the metrics for measuring the degree of flexibility within a WDS. These metrics include: the capability of the WDS to respond and the capability of WDS to react

to future change. These metrics are combined in to a single metric called the 'optimal level of flexibility' metric ( $F_{opt}$ ).

$C_{rs}$  depends on the range of uncertainty that the system is designed to handle (*Range of response-  $U_{rs}$* ) and the effort required to handle the specified range of uncertainties (*Cost of change-  $C_c$* ).  $U_{rs}$  indicates the pre-specified range of uncertain future developments for which a change in the WDS is required. In this study,  $U_{rs}$  is calculated from the future spatio-temporal water demand to which the system must respond.  $C_c$  is the measure of the effort/cost associated with the initial investment.

In contrast,  $C_{ra}$  indicates the nature and degree of change (in response to unknown future alterations) that the system is able to adapt to, beyond what it was designed for. This capability depends on the range of uncertainty to which the system is required to react (*Range of reaction-  $U_{ra}$* ) and the effort required to adapt to those unknown uncertainties (*Cost of adaptation-  $C_a$* ). In the design of WDS under demands of uncertainty,  $U_{ra}$  indicates a range of possible future water demand changes for which the WDS needs to change, and  $C_a$  indicates the effort associated with adapting to those possible uncertainties, including the costs for several possible changes in the whole life span of the WDS. Consider WDS<sub>2</sub> shown in Figure 3.11, which follows scenario [ $A_1T_0$ -  $A_2T_1$ -  $A_2T_2$ ] and required to adapt to scenario [ $A_1T_0$ -  $A_2T_1$ -  $A_3T_2$ ].  $U_{rs}$  represents the total water demand that the WDS<sub>2</sub> supplies over its lifetime and  $C_c$  represents the



associated optimal investment cost in NPV term. However, this system is required to adapt to demand state  $[A_3]$  at time  $t=T_2$ . Thus it must adapt  $U_{ra}$  range of demand from its state  $[A_1T_0- A_2T_1- A_2T_2]$  to  $[A_1T_0- A_2T_1- A_3T_2]$  at time  $t=T_2$  and require  $C_a$  amount of cost in order to adapt to WDS<sub>3</sub> as shown in Figure 3.11.

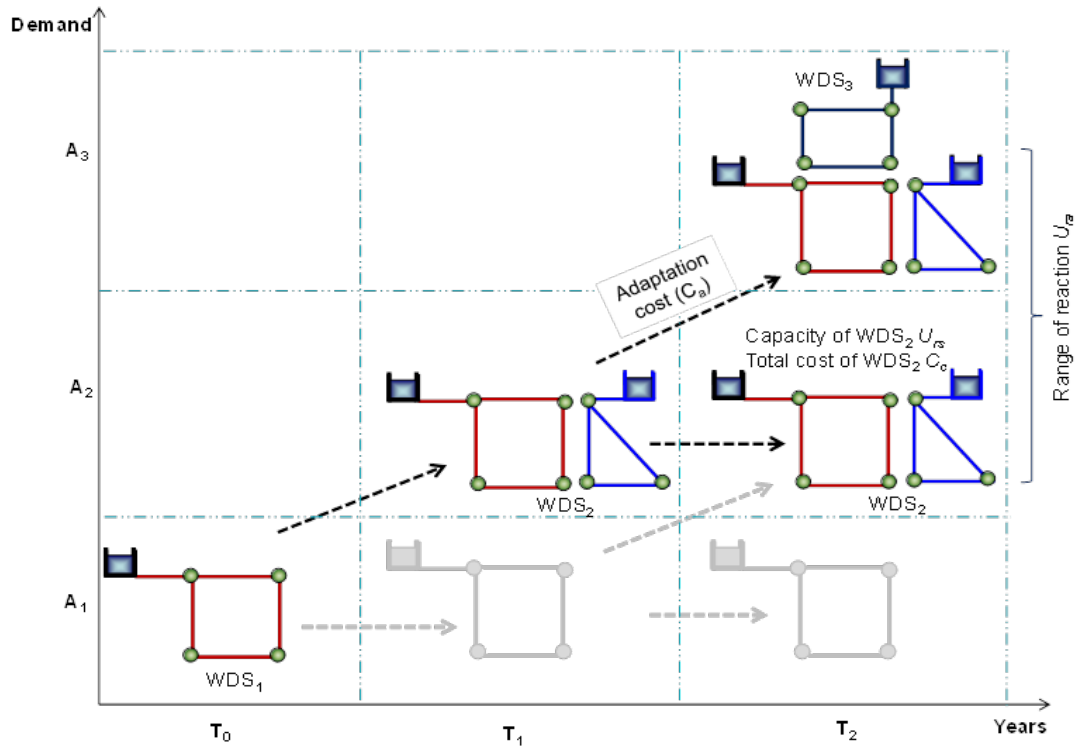

Figure 3.11 The range of response and adaptation, and associated cost

Different combinations of options, based on expected future uncertainties, could be embedded in WDS to offer different levels of flexibility within the range between excessively flexible and rigid. The values of  $C_{rs}$  and  $C_{ra}$  embedded in the optimized WDS is a point of critical consideration. Thus the combined value of  $C_{rs}$  and  $C_{ra}$  is explored to determine the level of flexibility ( $F_{opt}$ ) of different

WDS options. Flexible WDS design framework to determine the level of flexibility of WDS, and thereby to assist in decision-making, is presented in the next subsection. In addition, the research requires a specific chosen system as a baseline (usually a non-flexible system) for determining the economic gain as well as the associated regrets.

#### **3.2.4.1.1 The Capability to Respond ( $C_{rs}$ )**

The flexibility based GA optimizer returns the least cost for each alternative solution, but cost alone does not reflect the capability to respond to future change.  $C_{rs}$  is directly related to the range of water demand it can handle and inversely related to the effort (money) it requires. The larger the water demand that the WDS responds to, the higher its capacity and the higher the effort (cost) it requires to lower the capacity. Thus, in this study the  $C_{rs}$  is represented by the ratio of the range of response and the cost of change, as shown in Equation 3.1.

$$C_{rs} = \frac{U_{rs}}{C_c} \quad 3.1$$

where  $C_{rs}$  is the capability to respond to future changes;  $U_{rs}$  is the range of uncertainties to which the WDS can respond (i.e. the range of water demand the system can perform without losing its performance); and  $C_c$  is the Net Present Value (NPV) of the designed optimal WDS.

A WDS that has a larger  $C_{rs}$  performs better under uncertainty than a system with a smaller  $C_{rs}$ . Since flexibility requires the ability to react (adapt) to

different unknown future changes, an optimal WDS with a maximum  $C_{rs}$  doesn't necessarily guarantee flexibility. There is therefore a need to analyze WDS alternatives for different scenarios with respect to their adaptation capacity.

#### **3.2.4.1.2 The Capability to React ( $C_{ra}$ )**

$C_{ra}$  is the capability of a system to react to unknown future alterations. It is directly related to the water demand variation to which it is required to adapt and inversely related to the associated adaptation cost. It is represented by the ratio of the range of uncertainties to which the WDS needs to adapt (e.g. unexpected change in nodal demand) to the effort required (total cost to adapt to future change) as shown in Equation 3.2.

$$C_{ra} = \frac{U_{ra}}{C_a} \quad 3.2$$

where  $C_{ra}$  is the capability to react to the future alterations;  $U_{ra}$  is the range of uncertainties that the system can react to (range of adaptation); and  $C_a$  is the cost of adaptation required to change the system. In cases when either the cost of change or range of change is zero, the capability to react is taken as zero. A larger range of future uncertainties to which a WDS needs to adapt correlates to a higher capability to react to future alterations, while the higher the effort (cost) required to change the WDS, the lower the capability to adapt to future changes.

In this study, the parameters  $C_{rs}$  and  $C_{ra}$  will have unit dimensions in demand per unit cost (i.e. required adaptation demand of  $m^3/\text{year}$  per associated cost in \$). Confusion should be avoided, as this unit is different from the usual

unit cost parameters such as the amount of cost required for the unit capacity of a system in \$/m3/year.

### 3.2.4.1.3 Optimal Flexibility ( $F_{opt}$ )

In WDS design, the choice between WDS alternatives has to be made in the present without knowing the future. A system could have a large  $C_{rs}$  and yet its value delivery could be limited with the flexibility dimension  $C_{ra}$  that represents the adaptation capability to future conditions. The investment decision on the type of alternative to choose depends on the level of flexibility that comprises both  $C_{rs}$  and  $C_{ra}$ . The level of optimal flexibility that a system can deliver is represented by  $F_{opt}$ .  $F_{opt}$  and is the extent to and ease with which a system can cope with eventualities, which depends the combined effect of  $C_{rs}$  and  $C_{ra}$ . Equation 3.3 is used to determine the value of  $F_{opt}$  in terms of the  $C_{rs}$  and  $C_{ra}$  flexibility measuring criteria. Thus, decision makers might choose different weights to give to the  $C_{rs}$  and  $C_{ra}$  values.

$$F_{opt} = \omega_{rs}C_{rs} + \omega_{ra} C_{ra} \quad 3.3$$

where  $F_{opt}$  is the level of flexibility of a WDS,  $\omega_{rs}$  and  $\omega_{ra}$  are weighting factors for  $C_{rs}$  and  $C_{ra}$  respectively, and  $\omega_{rs} + \omega_{ra} = 1$ .

For example in Figure 3.9, the four scenarios are  $[A_1T_0- A_1T_1- A_1T_2]$ ,  $[A_1T_0- A_1T_1- A_2T_2]$ ,  $[A_1T_0- A_2T_1- A_1T_2]$ , and  $[A_1T_0- A_2T_1- A_3T_2]$ , and the optimal system-state mapping of the scenario are  $WDS_1$ ,  $WDS_{2a}$ ,  $WDS_{2b}$ , and  $WDS_3$ . When considering the optimized state  $WDS_1$ , which follows the scenario  $[A_1T_0-$

$A_1T_1 - A_1T_2$ ],  $C_{rs}$  is determined using the ratio of lifetime supply capacity of that  $WDS_1$  (i.e., corresponding water demand in the scenario) to the cost of  $WDS_1$  (capital cost NPV).  $C_{ra}$  is determined by the ratio of the range of water demand to which  $WDS_1$  needs to react to the cost required to adapt to all scenarios.  $F_{opt}$  is then determined using the weighted average value of  $C_{rs}$  and  $C_{ra}$ . The same procedure is followed to determine the  $F_{opt}$  values for the systems  $WDS_{2a}$ ,  $WDS_{2b}$ , and  $WDS_3$ . Similar approaches will be followed for different WDS alternative solutions for comparison.

Flexibility assessment indicates whether or not the selected option can deliver the required flexibility. Embedding options into a WDS may not guarantee flexibility and requires an iterative process where different flexible options are embedded and analyzed to determine whether or not they offer better flexibility ( $F_{opt}$ ). The choice of the level of flexibility is also based on current knowledge and is not a one-step decision; instead, decisions can be changed along the course of action based on how future uncertainties unfold.

#### **3.2.4.2 Decision Making Under Uncertainty**

Decision-making involving unforeseen events has been done using decision theory, utility theory, and game theory (Parsons and Wooldridge, 2002). According to Kahneman and Tversky (1979), decision theory helps decision makers choose among a set of WDS alternatives based on their possible consequences. In decision-making under uncertainty, the outcomes of choosing

different alternative states need to be evaluated. The decision-making process in decision theory recognizes the need for an evaluation of results associated with different alternative states and thus involves a ranking of the results based on the decision criteria. According to Finne (1998), decisions under uncertainty (unknown future conditions) are usually based on the following criteria: *maximax*, *maximin*, *laplace*, and *minimax regret*.

The *maximax* decision criterion is based on a “pure greed” state of mind of the decision maker. This criterion specifies that the decision maker should select the course of action that maximizes the maximum value of the other course of actions. This decision rule is an optimistic approach, in which the decision maker should assume the best of all possible solutions and is referred to as the “best best” payoff decision rule (Troffaes, 2007).

On the other hand, the *maximin* decision rule is based on a “pure fear” state of mind of the decision maker. It suggests that the decision maker should choose the course of action that maximizes the minimum payoff he can get (Einhorn and Hogarth, 1986). This pessimistic approach implies that the decision maker should expect the worst to happen. Here, the decision maker selects an action that, if things turn out for the worst, the *maximin* criteria provides the maximum payoff. This decision rule considers the worst consequence of each possible course of action and chooses the least worst one. This is sometimes referred to as the “best worst” payoff decision criterion (Lau and Chan, 2004).

The *Laplace* decision rule uses the highest average payoff across all the states of nature (outcomes) of all alternatives. It assumes that all the outcomes are “equally likely” (Lau and Chan, 2004) and the different actions should be evaluated according to their payoffs averaged over all the states of nature. It is referred to as the “best average” payoff decision rule.

The *minimax regret* rule selects the alternative that will minimize the maximum regret (Bell, 1982). According to Lau and Chan (2004), *minimax* regret decisions are based on “fear of guilt” and reduce the chance that the outcome will turn disappointing/regretful. This is also referred to as the “best worst” regret decision rule.

The choice of a decision rule is based on the type of decision maker, the system to be analyzed, and the problem under consideration. Both *maximin* and *maximax* approaches focus too narrowly on a single element in what may be a large payoff matrix. The *Laplace* decision rule also assumes that all the outcomes are equally likely, which does not exist in reality. However, the *minimax* regret rule offers the benefit of minimizing the future regret associated with the present decision, that is, the opportunity cost that will be incurred as a result of having made the wrong decision (e.g. profit/cost savings forgone).

A risk-neutral decision maker using *minimax* regret rule will select the option with the lowest regret/opportunity cost based on the assumption that the

maximum regret will occur for all the available decision options. It is one of the more credible decision-making criterion under uncertainty when the likelihoods of the various possible outcomes are not known with sufficient precision (Lipshitz and Strauss, 1997), which is the case for WDS. In this study, the *minimax* regret rule is chosen for flexibility-based decision-making in WDS design. The regret is represented by the opportunity loss associated with  $F_{opt}$  value. The larger the  $F_{opt}$ , the better the flexibility, and the lower the level of regret associated with it. Thus, the opportunity loss in terms of  $F_{opt}$  will be the difference between the maximum  $F_{opt}$  and the  $F_{opt}$  value of each alternative. The regret equation will therefore have the following form shown in Equation 3.4 to 3.6.

$$f_{R(s,j)} = \max\{F_{opt(s,j)}\}_{j=1}^r - F_{opt(s,j)} \quad 3.4$$

$$f_{R,max(j)} = \max\{F_{opt(s,j)}\}_{s=1}^m \quad 3.5$$

$$f_{R,min} = \min\{f_{R,max}\}_{j=1}^r \quad 3.6$$

where  $f_{R(s,j)}$  is the regret as a function of the capability to change for alternative solution  $j$  under scenario  $s$ ;  $f_{R,max(j)}$  is the maximum regret of WDS solution  $j$  under all scenarios  $s$ ;  $m$  represents the maximum number of scenarios considered;  $r$  is the maximum number of WDS solutions; and  $f_{R,min}$  is the minimax regret value.

For example, we might consider two WDS designed to perform under two scenarios for a period of one year. The  $F_{opt}$  associated with each alternative is shown in Table 3.1. In this example, there are two decision options ( $WS_1$  and  $WS_2$ ) and two conditions (Scenario-1 and Scenario-2).



Table 3.1  $F_{opt}$  value for alternative WDS under two different scenarios

Scenarios	$F_{opt}$ ( $m^3/yr/\$$ )	
	$WS_1$	$WS_2$
1	13	11
2	16	19

If  $WS_2$  is chosen and Scenario-1 happens, the decision maker suffers an opportunity loss of  $2m^3/yr/\$$  (where the opportunity loss associated with  $WS_1$  will be zero). However if Scenario-2 happens, the opportunity loss associated with  $WS_1$  will be  $3m^3/yr/\$$  while  $WS_2$  will have no opportunity loss. The opportunity losses for each alternative under each scenario are shown in Figure 3.8.

Table 3.2 Opportunity losses associated with each option

Scenario Path	$f_R$ (regret)	
	$WS_1$	$WS_2$
Scenario-1	0	2
Scenario-2	3	0
<b>Maximum regret</b>	<b>3</b>	<b>2</b>
<b>Minimax regret</b>	<b>2 (<math>WS_2</math>)</b>	

Based on the *minimax* regret (opportunity loss) principle, the option that minimizes the maximum possible regret will be chosen. Thus, between the two alternative options,  $WS_2$  has the minimum regret, which dictates that it should be considered a better option. This decision approach is used to evaluate the flexibility measuring criteria of a large number of design options under a wide range of scenarios in the design of flexible WDS. The design option with the

minimum opportunity loss related to  $F_{opt}$  value is expected to perform better under a changing environment.

The decision-making process in developing flexible WDS considers a baseline as a benchmark to which different alternatives can be compared. The baseline system is a non-flexible/robust WDS designed and operated in a traditional way (Nilchiani and Hastings, 2007). Indeed, often a non-flexible/robust system is considered as a baseline. The comparison is used to evaluate the value added to the system by flexible design. The alternative with the largest value added, when compared to the non-flexible baseline, represents the most flexible WDS alternative that delivers a high flexibility value.

Chapters 5 and 7 apply this methodology to develop a centralized flexible WDS for Mbale town, Uganda and a clustered (decentralized) WDS for Arua town, Uganda. Comparisons are also made between a system designed based on traditional approaches and a flexible WDS designed using the developed methods in this study.

### **3.3 Conclusions: Framework for Design of Flexible WDS**

This chapter has developed a framework for designing and optimizing flexible WDS that can cope with future change and associated uncertainties in a cost effective, performance efficient, and timely manner. The framework is based on GA optimization techniques and involves four major steps:

- i) Uncertainty description: a scenario tree is used to reflect multiple possible future states in a simple tractable manner to answer the question.
- ii) Identifying flexibility options: a suite of flexible options is identified which are expected to offer better lifetime flexibility to the WDS.
- iii) Generating Flexibility: to generate flexibility in centralized WDS GA based flexibility optimization (GAFO) model is developed. In addition an optimization model for clustering emerging areas to allow implementation of flexible decentralized WDS is developed. The optimization of the each clustered WDS is done using GA optimization.
- iv) Decision-making under uncertainty: This involves flexibility assessment and comparison that indicates whether or not the selected option can deliver better flexibility. To support the decision about which flexible alternatives should be selected, the *minimax* regret rule is applied.

The framework for the design and optimization of a flexible WDS focuses on minimizing the cost of the system, and the decision regarding the best alternative is based on the performance matrices developed, which are the capability to respond and react to change. These performance metrics allow for the flexibility of an urban water system to be assessed. Other metrics of flexibility, such as the performance or the duration of change, are not considered, as the optimization assures the minimum performance requirement (pressure head) for all systems and assumes that the duration of change of a system is minimal with respect to duration for change in future conditions. The framework is applicable

for all urban water systems, where the optimization process is only focused on WDS, assuming a comparable performance.

The framework optimizes the flexibility of WDS with a predefined set of flexibility options. The decision of which flexibility options should be considered in the optimization process is not supported by the framework. A question for future research is how to provide guidance on the identification and selection of suitable flexibility options.

In Chapter 4, the GA based flexibility optimization (GAFO), a core element of the framework, will be presented in detail. The framework will be applied to two case studies with different types of WDS. In Chapter 5 the framework will be applied for a centralized WDS in order to analyze how much the flexibility is improved in comparison to a conventional centralized system and centralized system optimized for a range of uncertainty. In Chapter 6 the framework is applied for clustered WDS and it is assessed to determine if a clustered system provides a higher flexibility than a conventional centralized system.

## 4 Optimization for Flexible Design of Centralized WDS

### 4.1 Introduction

This chapter addresses the specific research objective of developing an optimization model that maximizes the flexibility of WDS at the least cost. As a result, this optimization model will generate a flexible, staged development plan for the incremental growth of the WDS.

In this chapter a new approach for the flexibility-based optimization of WDS based on a Genetic Algorithm (GA) optimization technique is proposed, and a new modelling tool called Genetic Algorithm based Flexibility Optimization (GAFO) is developed. GAFO allows optimizing WDS for a wide range of uncertainties with minimal costs and helps to design flexible WDS that are adaptable to new, different, or changing requirements. The optimization model is part of the framework for the flexible design of WDS presented in Chapter 3, where it is presented briefly (see Figure 4.1)

This chapter is divided in two parts. First, the specific optimization problem for the flexible design of WDS is developed. Second, the GAFO model is developed in order to solve the described optimization problem. At the end of the chapter the proposed GAFO model is applied to a hypothetical water distribution

network. Applications of the GAFO model to real world case studies are presented in Chapter 5 and 6.

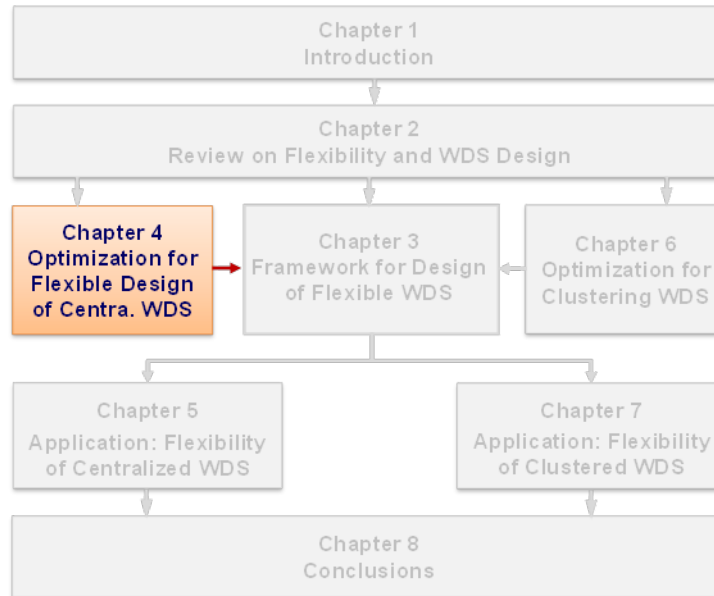

Figure 4.1 The interconnection of Chapter 4 with other chapters

## 4.2 Optimization Problem for Flexible Design of WDS

### 4.2.1 Basic Optimization for WDS

Problem formulation in the design of WDS involves design variables, objective functions, and constraints. A design variable in an optimization problem refers to any quantity or choice directly under the control of the designer. It involves many forms, as WDS are comprised of many components and performance criteria. Design variables may include the selection of diameters for pipes, pump types, and locations, the sizing and locating of tanks, valve pressure settings, and valve locations. A constraint is a condition that must be satisfied in

order for the design to be feasible. Constraints can reflect resource limitations, user requirements, or bounds on the validity of the analysis models. The general constraints in the hydraulic analysis of a WDS are continuity and energy equations. Bound constraint conditions in a WDS optimization problem could be specified to include minimum and maximum allowable pressures at each demand point, minimum and maximum velocity constraint for each of the pipes, and water quality requirements. Further constraints may be added for materials as well, such as allowing for different rehabilitation alternatives (cleaning, relining, or both) (Walski et al., 2003). According to Mays (2000), the main constraint in a WDS optimization problem is supplying the desired water demand with adequate pressure head at the withdrawal nodes. The optimal design of a WDS is often viewed as the least cost optimization problem (Zecchin et al., 2005)—a problem in which the value of cost should be minimized. However it has also been applied for different objectives in designing and operation of WDS. These include whole life cost, network reliability, redundancy, water quality, pump scheduling and maintenance/rehabilitation, WDS model calibration, valve location, etc. (Savic, 2002). Considering capital cost, the overall optimization problem for finding the least cost combination of pipe size can be expressed mathematically, as shown in Equation 4.1 through 4.5.

$$\text{Minimizing} \quad f_{cost}(D) = \sum_{j=1}^N C(D_j, L_j) \quad 4.1$$

$$s. t, \quad \sum Q_{in} - \sum Q_{out} = Q \quad 4.2$$

$$\sum h_f - \sum E_p = 0 \quad 4.3$$

$$H_{min} < H < H_{max} \quad 4.4$$

$$D \in \{A\} \quad 4.5$$

where  $f_{cost}(D)$  is the cost of the pipes;  $N$  is the number of pipes;  $D$  is the design variable pipe diameter;  $C(D_j, L_j)$  is the cost of component  $j$  with diameter  $D_j$  and length  $L_j$ ;  $Q_{in}$  is flow into a junction;  $Q_{out}$  is flow out of a junction;  $Q$  is external flow or demand at each node;  $h_f$  is pipe head-loss;  $E_p$  is energy input by a pump;  $A$  is the specified commercially available size; and  $H_{min}$  and  $H_{max}$  are the lower and upper limits of the nodal pressure head.

For pipe cost, it is assumed that the capital cost per unit length of pipe varies nonlinearly with its diameter and can be expressed by a single expression for all diameters  $C(D_j, L_j) = K L_j D_j^n$  where  $K$  and  $n$  are regression coefficients that depend on the local pipe cost function.

The above equations are based on a generic optimization formulation that follows a fixed set of system objective requirements over time. In designing flexible WDS, the changing system's requirements that take into account the possible scenario paths should be considered. Thus, the next sections focus on developing a unique optimization function for flexible design of WDS that have the ability to adapt to different future conditions.



#### **4.2.2 Unique Objective Function for Flexibility Optimization**

The focus of flexibility based optimization is to maximize the ability of the system to adapt to new, different, or changing requirements. The flexibility of a system to cope with an ever-changing environment requires the ability to change or react in a performance efficient and cost effective manner. Thus, the development of an objective function for flexibility focuses on minimization of the investment and adaptation cost associated with the changing environment, while the minimum required performance is maintained for all possible future conditions.

This chapter develops an objective function for flexibility based on two unique features: (i) the objective function should consider a wide range of uncertainties for which the system needs to cope, and (ii) the objective function should involve a staged function such that adaptation from one stage to another is possible to cope with future change requirements. These two unique features of the objective function will be critical in optimization of flexibility enhanced changeability from one state to another. Also, this approach enhances a number of possible trajectories which allows the WDS to make a stepwise evolution over time. The proposed flexibility based design objective follows the same pattern as the scenario tree description of uncertainties. For example, considering demand ranging between minimum ( $Q_1$ ) to maximum ( $Q_2$ ), the objective function for flexibility minimizes the WDS cost for all possible discrete future scenarios

ranging between demand  $Q_1$  and  $Q_3$ . This involves minimizing the cost for each scenario state ( $S_t$ ) and each time stage ( $t$ ).

The proposed flexibility based objective function is based on the input scenarios that represent future uncertainties (number of stages and states of the future condition such as future water demand). Thus it is formulated to minimize the Net Present Value (NPV) associated with both investment at each stage and adaptation to the future states. The nature of this optimization problem requires a nested loop process that involves the following components:

- i) It considers a wide range of possible future states (scenarios), and the cost function involves the sum of the cost values of all states at each stage as shown in Equation 4.6. This involves future states  $s = \{0, 1, 2, \dots, m\}$  where  $m$  is the maximum number of states at each stage ( $t$ ). Also Figure 4.2 illustrates how the first loop function is calculated (at each stage).

$$f_t(D) = \sum_{s=1}^m \frac{1}{(1+r)^{t\Delta t}} \left( \sum_{j=1}^N K L_j D_j^n \right)_s \quad 4.6$$

where  $f_t(D)$  is the cost of the pipes at each stage;  $L_j$  is the length of the  $j$ th pipe;  $N$  is the number of pipes;  $D$  is the design variable defining the dimension of components (i.e pipe diameter);  $t$  is the design stage,  $\Delta t$  is the period in each stage,  $r$  is the discount rate;  $m$  is the maximum number of future states ( $s$ ); and  $K$  and  $n$  are regression coefficients for pipe cost function.

ii) The cost function involves the summation of the cost values from step i.

This means that the sum of the cost values of all stages is summed such that the objective function is minimized over the whole range of stages.

Equation 4.7 is used to determine the cumulative cost values. Figure 4.2 illustrates how the second loop function is calculated for each stage.

$$f_{cost}(D) = \sum_{t=0}^{S_t} f_t \quad 4.7$$

where  $f_{cost}(D)$  is the total cost of the initial investment and adaption;  $t$  is the design stages  $\{0, 1, 2, \dots, S_t\}$ ;  $S_t$  is the maximum number of staging in the design horizon.

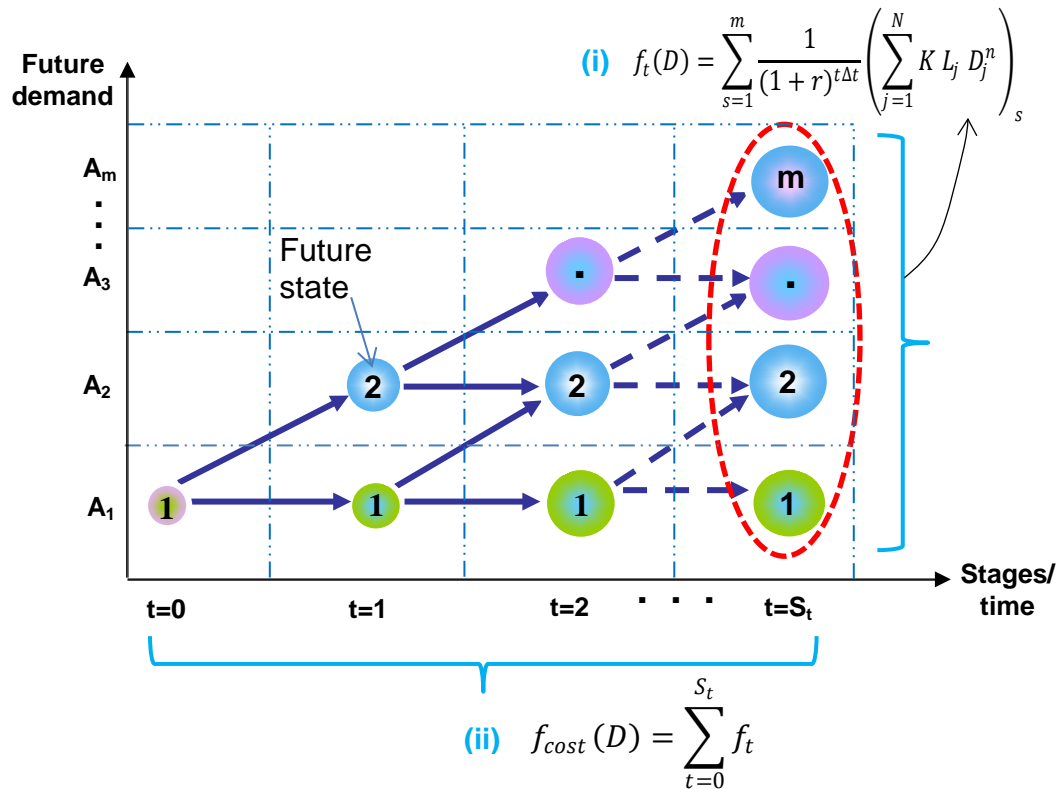

Figure 4.2 Optimization objective function for all possible future states

As shown in Figure 4.2, the objective function is a convoluted process in which an evaluation of all future states at each stage is first performed and then summed for all stages. For the least cost flexibility optimization problem the combined equation can be mathematically expressed as shown in Equation 4.8. This equation combines all the cost values for all possible states of all stages to which the system needs to adapt.

$$\text{Minimizing, } f_{cost}(D) = \sum_{t=0}^{S_t} \left[ \sum_{s=1}^m \frac{1}{(1+r)^{t\Delta t}} \left( \sum_{j=1}^N K L_j D_j^n \right) \right]_{s_t} \quad 4.8$$

where  $f_{cost}(D)$ ,  $D$ ,  $K$ ,  $L$ ,  $N$ ,  $\Delta t$ ,  $r$  and  $n$  are as stated above;  $t$  is the design stages  $\{0, 1, 2, \dots, S_t\}$ ;  $S_t$  is the maximum number of stages in the design horizon.

Equation 4.8 involves a nested loop process of optimization. For each  $t=\{0,1, 2, \dots, S_t\}$  the objective function spans through  $s=\{1,2, \dots, m\}$  where  $m$  varies for each time stage ( $t$ ). For example, in Figure 4.2 at time stage  $t=1$ , the maximum number of future states  $m$  is 2, whereas at time  $t=2$  the maximum number of future states  $m$  is 3. This process introduces a new approach in designing WDS that advances the process of optimization that takes into account future uncertainties and enhances flexibility. This enables the system's ability to adapt to a changing environment and allows for exploring flexibility alternatives that offer better value under uncertainty.

### 4.3 Genetic Algorithm Optimization Model for Flexible WDS

During the last two decades, the design of WDS has shown a drastic increase in the development and application of various types of optimization tools, one of which is the evolutionary algorithm (EA). Genetic Algorithm (GA), which is implemented in this study, is one of the most popular types of EAs (Espinoza et al., 2006; Nicklow et al., 2010). Recently, there has been a growing interest in the application of GA for the design of WDS. GA has proved to be a flexible and powerful tool in solving complex water distribution optimization problems (Simpson et al., 1994). GA provides a stochastic optimization approach. It is basically described as an artificial adaptive heuristic search algorithm based on the genetic process and evolution principle of biological organisms, which includes reproduction, natural selection, and diversity of the species (Popov, 2005).

According to Lopez-Pujalte et al., (2003), GAs use a randomly generated input population called *chromosomes*. This input population represents possible solutions to the problem, and each chromosome therefore represents one individual solution. These “individuals” evolve over successive iterations known as *generations* by means of the processes of *selection, crossover, and mutation* (a detailed discussion of this is presented in the following subsections). According to Dijk et al. (2008), GAs imitate nature’s optimization techniques of evolution, based on the following characteristics:

- i) Survival and reproduction of the fittest members of the population

- ii) The maintenance of a population with diverse members
- iii) The inheritance of genetic information from parents
- iv) The occasional mutation of genes

GA differs from the traditional approaches of existing optimization techniques (Simpson et al., 1994). They are better suited for the optimization of WDS problems than traditional optimization techniques such as nonlinear programming and linear programming for a number of reasons, which are outlined below (Raad et al., 2010; Vairavamoorthy and Ali, 2000).

- i) GA handles discrete design variables like pipe diameter
- ii) GA does not rely on the continuity of derivatives of the objective function or the constraint
- iii) GA deals directly with a population of solutions at any one time and is much less likely to restrict the search to a local optimum, compared with point-to-point movement optimization techniques, which tend to operate in that manner.

This research strives to illuminate and exploit the benefits that GA offers to the design of flexible WDS. Many researchers have indicated that GAs will give nearly optimal solutions with a reasonable number of iterations (such as Babayan et al., 2007; Nicklow et al., 2010; Savic, 2005; Vairavamoorthy and Ali, 2000). According to Huang (2012), GA performs better in designing flexible WDS under uncertainty. Designing for flexibility requires optimizing over a wide range of

future uncertainties that involve large design space; likewise the optimization objective function formulated in Equation 4.8 requires a number of stages and states of future uncertainties to be considered. The time and states of future conditions are represented by discrete decision stages (along with a scenario tree). These require optimization algorithms that better handle discrete decision variables.

This study proposes a GA based flexibility optimization and develops a tool called Genetic Algorithm based Flexibility Optimization (GAFO) in order to allow for the stepwise evolution of WDS over time by embedding flexibility into the design of WDS. The GAFO model code is developed using a C++ programming language. The major steps that GAFO includes are the generation of an initial population, hydraulic analysis, uncertainty-based fitness evaluation, generation of a new population (using selection, cross-over, and mutation genetic operators) and termination (see Figure 4.3). GAFO algorithm shown in Figure 4.3 differs from those outlined in previous works in the following two major aspects:

- i) Optimization in this approach is performed for a range of future conditions. This means that a system will be evaluated with respect to its ability to cope with future changes. In addition, a modified penalty function is used to evaluate the system's performance over a wide range of future uncertainties.

- ii) Optimization in this approach is also based on staged decision-making, which allows for stepwise evolution of the WDS through time.

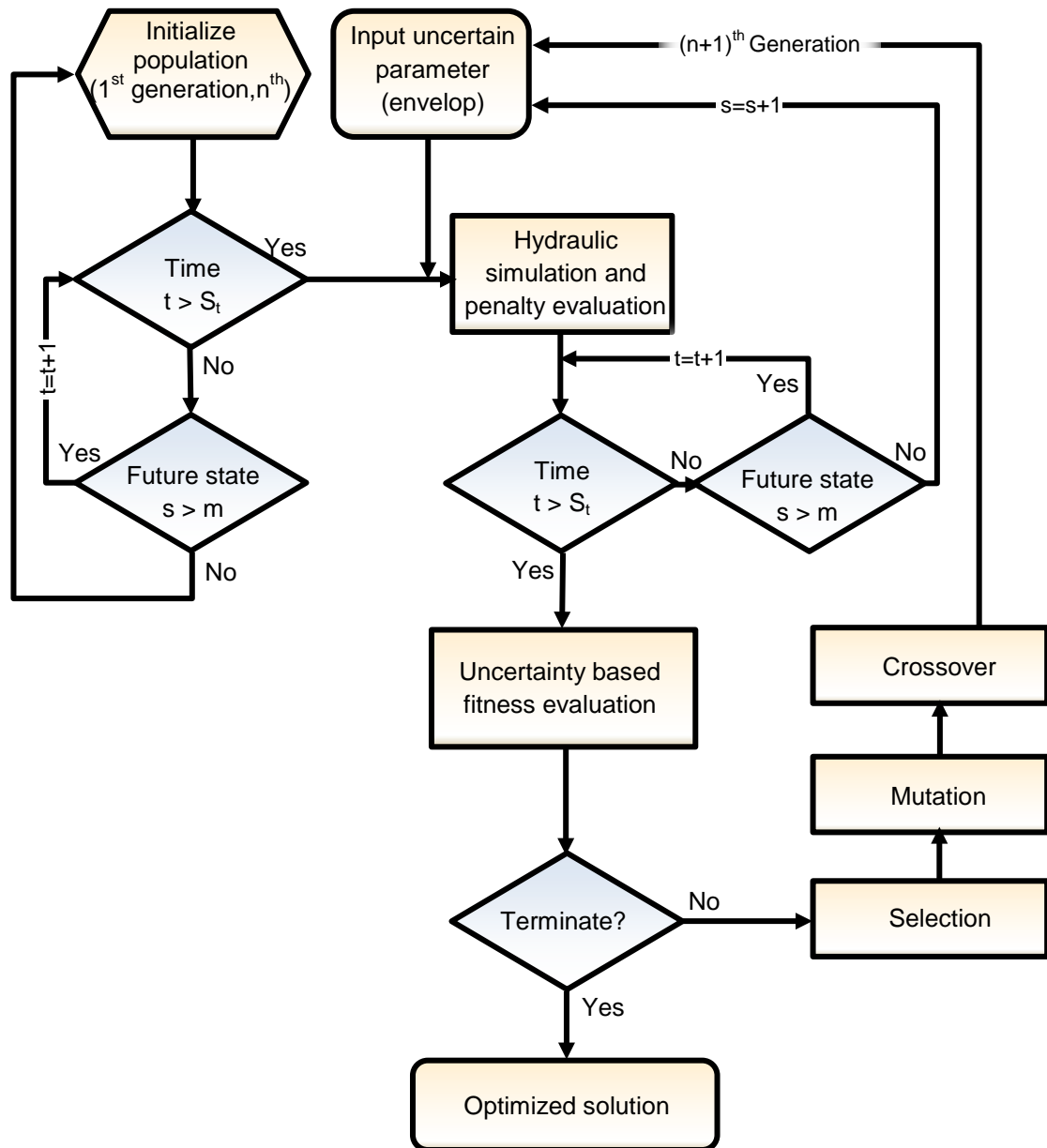

Figure 4.3 GAFO model algorithm ( $t$  is the design stages  $\{0, 1, 2, \dots, S_t\}$ ;  $S_t$  is the maximum number of staging in the design horizon,  $m$  is the maximum number of future states  $s$  at each stage  $t$ )



For example, as shown in Figure 4.3, the initialization of a random population in the GAFO model is done for all possible future conditions (all future states 's' and time stages 't'). The hydraulic simulation and penalty calculations also involve a convoluted loop process that requires a range of uncertain input parameters described by future state and design stage (t). Similarly, the fitness function that involves the minimization objective function is performed for a whole range of future conditions. This allows the GAFO optimizer to explore the fittest population that allows a stage wise evolution of the WDS under different future conditions. The details of the GAFO optimization process is presented in the next subsection.

#### **4.3.1 Generation of Initial Population**

GAFO generates the initial random population of 'n' number of chromosomes (possible solutions to the problem) using a random generator. This represents a possible initial pipe network solution (string) in the design of a WDN. The unique feature of this optimization is that the initialization involves a population of possible pipe network solutions (string) for each state (s) at each stage of the design (t). This helps the GA optimizer to search for optimal solutions which perform over a wide range of uncertainties. The GA's search for possible solutions depends on the size of the population chosen, usually set by the user at the beginning of the optimization process. According to Popov (2005), a small population provides an insufficient sample size—causing premature performance—while a large population size requires more time to converge the

population. As such, the process of selection behind the population size is that it should be set proportionally to the size and difficulty of the problem. Many users end up using the so-called standard setting of 50-100 individuals (Gupta, 1998). In contrast, some optimization models employ an adaptive population size approach. This was done by Lobo and Lima (2007) and Brest and Maucec (2008). However, variable population size optimization process is not the focus of this study. For this study, an initial population size is set at the beginning of optimization and remains constant throughout the GA run. Based on the population size, the GAFO performs a random selection of pipe diameters from a pre-specified list of available pipes to develop an initial solution (for all possible future states).

The initial population is represented by discrete pipe diameters. For example, considering four available pipe diameters, 101.6mm, 152.4mm, 203.2mm, and 254mm, a vector [101.6, 152.4, 203.2, 254] represents a suite of possible pipe diameters. GA pipe solutions (populations) could be represented either by binary or integer chromosomes. If the solution network consists of pipe diameters [152.4, 203.2, 203.2, 152.4], GA representation of the solution vector with binary and integer chromosomes is listed as shown below.

- i) Binary 

0	1	0	0	1	1	0	0	0	1	0	1
---	---	---	---	---	---	---	---	---	---	---	---
- ii) Integer 

1	2	2	1
---	---	---	---

Even though either binary or integers may be used, the binary code requires longer chromosomes to represent the solution vector than the integer code and requires much more processing time and computer memory. It also requires huge effort to convert to discrete pipe diameters when evaluating the total cost. In addition, binary coding generates redundant states that do not represent any of the design variables, resulting in poor performance of the GA (Vairavamoorthy and Ali, 2000). Therefore, in this study the GAFO employs an integer coding technique to represent the solution for the flexible design of WDS.

#### ***4.3.2 Hydraulic Analysis for a Range of Uncertainties***

This stage involves the simulation of a hydraulic solver. In this study, the hydraulic simulation software EPANET (Rossman, 2000) is used to compute the pressure head and supply at each node and discharge in each pipe under the specified input parameters. In GAFO, the determination of pressure head and supply at each node is analyzed at each state and stage of the future condition described by the scenario tree. Thus, the result of the hydraulic analysis for a wide range of uncertainties is used to evaluate the performance of each population in a generation. A minimum pressure head at each demand node is used as a constraint. The actual heads are compared with the minimum required heads, and GAFO determines the pressure deficits in order to identify the populations that do not perform well.

### 4.3.3 Uncertainty Based Fitness Evaluation

#### 4.3.3.1 Computation of Penalty Function

The GA identifies the pipes supplying the node that does not meet the minimum required pressure and assigns to them a penalty cost. However, the identification of a suitable penalty function is one of the challenges of an optimization problem. Dijk et al. (2008) have suggested the use of extensive penalties to emphasize the poor result of the pipes supplying negative pressure nodes. Siedlecki and Sklansky (1993) and Vairavamoorthy and Ali (2000) suggested a variable penalty coefficient based on the degree of violation. The variable penalty coefficient is determined heuristically and depends on the level of violation, as shown in Equation 4.9. The penalty coefficient is a measure of the worth per meter attributed to pressure heads below the allowable minimum pressure head (Simpson et al., 1994).

$$P_c(D) = \sum_{i=1}^n P_{K,i} \begin{bmatrix} |H_i - H_{min}| & , \text{ for } H_i < H_{min} \\ 0, & \text{ for } H_i \geq H_{min} \end{bmatrix}, \quad 4.9$$

where  $P_c$  is penalty cost and  $P_k$  is the penalty coefficient for the  $K^{th}$  level of violation and the  $i^{th}$  pressure constraint (Vairavamoorthy and Ali, 2000).

The penalty function is used to measure the performance violation at each node under a range of uncertainty. The following three unique features are considered in determination of a penalty function for GAFO.

- i) The GAFO is formulated for a staged design where the performance of WDS is checked at different design periods in consideration of the range of uncertainties.
- ii) The performance violation of the WDS from the minimum required should consider all possible ranges of uncertainty. The range of uncertainties at each design stage is defined by the state of nature (i.e. water demand values).
- iii) In addition to different future states, the idea of weighted penalty is used, which suggests that the pipes that supply more water are more important than the ones that supply less water (Dijk et al., 2008). The weighted penalty considers the proportion of the distribution of supply pipes' importance, based on their flow rate ( $Q_{node}/Q_{total}$ ) (Dijk et al., 2008). As such, the unique penalty function for flexibility is shown in Equation 4.10 below.

$$P_c(D) = P_k \sum_{t=0}^{S_t} \sum_{s=1}^m \left( \sum_{i=1}^n \frac{Q_{i,t}}{Q_t} * \begin{bmatrix} (H_{i,t} - H_{min}), & \text{for } H_{i,t} < H_{min} \\ 0, & \text{for } H_{i,t} \geq H_{min} \end{bmatrix} \right)_{s,t} \quad 4.10$$

where  $P_c$  is the penalty cost term;  $P_k$  is a penalty coefficient;  $t$  is the design stage  $\{0, 1, 2, \dots, S_t\}$ ;  $r$  is the discount rate; and  $m$  is the maximum number of scenarios ( $s$ ) that represent future uncertainty.

In this chapter, the penalty function is developed for the pressure bound constraint function. However, a similar approach could be followed to determine

the penalty functions for other constraints in case they exist (one example of this is velocity). Once the penalty term is determined for the pipes, which results in the nodal pressure deficit, the modified total cost for each string is calculated by summing the network cost and penalty costs (Equation 4.11). The modified total cost ( $T_c$ ) is then used to determine the fitness of the solution.

$$T_c = f_{cost}(D) + P_c(D) \quad 4.11$$

#### 4.3.3.2 Fitness Evaluation

The GAFO search uses fitness calculation to identify the best solution to the optimization problem. The fitness function is a measure of how close the given design solution is to achieving the objective function. The performance of each string is measured based on the fitness function. Unlike traditional GA optimization, the unique nature of the GAFO search mechanism evaluates fitness for the whole range of uncertainties. This means the fittest solution will perform better for a wide range of future conditions. The fitness of the string is usually taken as some function of the objective function. One form of the fitness function (based on the minimum cost objective function) is to use the inverse of the total cost (network +penalty cost) (Chan et al., 2002), as shown in Equation 4.12.

$$f(D) = \frac{1}{f_{cost}(D) + P_c(D)} \quad 4.12$$

where  $f_i$  represent the fitness of  $i^{th}$  string (solution WDS).

Though designers may choose different forms of the fitness function, according to Simpson et al. (1994), the function as shown in Equation 4.12 provides the most effective solutions from the GA search by ensuring the lowest cost string to survive.

#### **4.3.4 Generation of New Population Using Reproduction**

As previously mentioned, the GA mimics nature's optimization techniques. As such, the next step of the GA is to use the current population to create the children that make up the next generation. The GA generates a new population by performing the necessary steps until the new generation is formed. These steps include *selection, crossover, mutation, and accepting* and are outlined in this section.

*Selection* is the process of choosing parent strings from the population. The GA selects parent strings based on their fitness value; the selection of individuals is performed by survival of the fittest. The more an individual fits to the environment, the higher its chances are to survive and to create a new offspring of the new population (Popov, 2005). Different selection schemes may be used, such as truncation selection, tournament selection, ranking selection, and proportional selection. In the case of truncation selection the individuals are arranged based on their fitness value, and some proportion ( $p$ ) of the best individuals will be selected with the same probability  $1/p$  (Crow and Kimura, 1970). This method is less sophisticated than other methods and is not often

used in designing WDS (Goldberg and Deb, 1991). Tournament selection is based on choosing random individuals from the population and selecting the best individual as a parent (Blickle, 1995). This is done by running several “tournaments” for which the winner of each tournament is selected for crossover. The selection pressure could be changed by varying the tournament size, where larger tournament sizes mean that weaker individuals have a smaller chance to be selected (Blickle and Thiele, 1995). According to Goldberg and Deb (1991), tournament selection requires a number of searches and is not very useful when a large population size is used. Ranking selection involves sorting the individual solutions based on the objective function and assigning the fitness to each individual depending on its position in the group (rank) (Grefenstette and Baker, 1989). Rank one is assigned to the weakest individual and the maximum ranking to the fittest individual. It behaves in a more robust manner than other methods (Back and Hoffmeister, 1991; Whitley, 1989). Roulette-wheel selection is also known as fitness proportionate selection, where the chance of solutions to be selected is proportional to its fitness value (Holland, 1975). Individuals with a higher value of fitness will have a higher chance of being selected. This is a popular approach (Goldberg and Deb, 1991) in which the selection probability is determined by the probability of fitness value. This study examines the performance of the proposed GAFO for both the ranking and Roulette-wheel selection schemes.



In the proposed GA, the string with a higher value of modified fitness function will have a higher chance of being selected, which is basically determined by the probability of fitness value of the strings. Equation 4.13 follows the spin of the roulette-wheel process, for which the probability of the selection of a particular string for reproduction is given by:

$$P_f = \frac{f_i}{\sum_{i=1}^n f_i} \quad 4.13$$

where  $f_i$  is the fitness of string  $i$  in the population;  $P_f$  is the probability of the string  $i$  being selected using roulette-wheel, and  $n$  is the number of individuals in the population.

In ranking, the probability of selection is determined from the sum of ranks  $r$ . Equation 4:14 is used to determine the probability of selection based on ranking.

$$P_r = \frac{r_i}{\sum_{i=1}^n r} \quad 4.14$$

where  $r_i$  is the ranking of string  $i$  in the population;  $P_r$  is the probability of the string  $i$  being selected using the ranking selection scheme, and  $n$  is the number of individuals in the population.

The individuals that are retained based on their fitness value through the selection process are called *elite children*. Once relatively good strings are chosen, a reproduction process is performed by the genetic operators crossover

and mutation. *Crossover* is the process of recombination of parents to produce their new offspring (children). This is the point where the genes of strings between the parents are transferred. One randomly sampled breaking (cut) point along the chromosome is used to swap the partial string from each chromosome.

A typical recombination in the GA requires that two parents and a single point crossover is performed, but schemes with more parent areas and multiple crossover points are also possible (Popov, 2005). In this study the flexibility based GA is examined for both one-point and two-point crossover methods and the one that performs better is chosen. One-point crossover is where a random single point on chromosome is selected and the string is swapped between parents. Two-point crossover is where two crossover points are selected and the parent strings swapped between two points. According to Simpson et al., (1994), the crossover between parents is performed based on the crossover probability. A typical range of crossover probability ranges between 0.6 and 0.9 (Eiben and Smith, 2003). For example, considering a crossover probability of 0.75, the GA randomly picks two strings and generates a random number in the range of 0 to 1, and the crossover is performed if the random number is less than 0.75.

*Mutation* is an occasional flipping of genes that prevents the loss of potentially useful genetic information. This process provides a small local change of feasible solutions to embed the changeability of the string and to steer away from convergence to the local optimum solution. The newly generated population

(the network solution developed by selection and crossover) is further subjected to a random change of the value of a gene (pipes) from the available pipe size based on the mutation rate. The probability of mutation often ranges from 0.01 to 0.05 (Eiben and Smith, 2003). According to Simpson et al. (1994),  $1/n$  is used as a guideline for computing the probability of mutation, where  $n$  is the size of the population. According to Srinivas and Patnaik (1994), the optimal mutation rate depends on the type of problem. Thus, this study will examine the proposed GAFO for a wide range of mutation (0.035 to 0.08) with respect to the progression rate of the GA.

To avoid the loss of the best population in the generation, the GA passes the chromosome with a high fitness value to the other generation without any crossover and mutation. This population is then either replaced with another better population or remains unchanged if there is not a better population in the subsequent generations. Once the selection-crossover-mutation is performed, the new offspring is placed into the population. This final step is called “*accepting*” the new child.

#### **4.3.5 Production of Successive Generation and Termination**

The individuals who pass the selection-crossover-mutation process described above form a new generation, and the reproduction cycle goes on until an appropriate termination condition is met. GA repeats the above steps to generate successive new generations. As the number of generations increases,

the individuals in the population get closer and converge to the objective function (Eiben and Smith, 2003). For a least cost GA optimization process, the least cost strings are stored and updated as a cheaper alternative. This process repeats until the termination criteria are satisfied. Most GA optimizations use the following termination criteria (Safe et al., 2004):

- i) Maximum Generation: The GA stops when the number of generations reaches the value of the initially specified generations.
- ii) Time limit: This criterion is based on getting some result within a period of time. It returns solution strings within a specified number of iterations, whether it has reached the extreme or not.
- iii) Fitness limit: This criterion is based on an initially specified fitness limit. The GA stops when the fitness function for the best string in the population is less than or equal to the fitness limit.
- iv) Stall generation: This criterion is based on whether there is improvement in the fitness function. The GA terminates if there is no improvement in the fitness value of the best individual over stall generations.
- v) Stall time limit: This criterion is also based on the improvement of the objective function over an interval of time (stall time limit). The GA stops when there is no improvement in the objective function during the stall time limit.

The options *stall time limit* and *time limit* prevent the algorithm from running too long, but may not return an optimum value. According to Dijk et al.

(2008), the simplest stopping criteria use a fixed number of generations or alternatively use a stall generation where the reproduction cycle terminates when no improvement is observed in the fitness value of the best string in some fixed number of generations. In this study both the maximum generation and stall generation stopping criteria are used.

#### **4.3.6 Guideline for the GA Based Flexibility Optimization**

Unlike other traditional GA optimization techniques used by different researchers (Simpson et al., 1994; Babayan et al., 2007; Giustolisi et al., 2009; Nicklow et al., 2010), GAFO performs the optimization in stages for a wider range of possible future states. To guide designers implementing the developed GAFO model for the design of flexible WDS, the optimization process has been summarized in 10 steps below.

- i) Read network data, cost data, required minimum pressure, probability of mutation, population size, maximum number of generation, penalty factor, design horizon, design stages, and number of decision points (scenario nodes).
- ii) Read scenario data for the uncertain parameters. This is a range of future water demand scenarios described by future state (s) and time stages (t).
- iii) Generate initial population using random generator for all possible future state (s) and time stages (t). This represents a possible initial pipe network solution in the design of WDN.
- iv) Counter 1.

- v) For all population perform the following:
  - a) Call the WDS design software EPANET and perform a hydraulic analysis to determine the flow and nodal pressure values. This is performed under all possible scenarios (step ii).
  - b) Evaluate the cost of the solution networks. This is the NPV associated with the solutions for all scenario states (s) and time stages (t).
  - c) If the solution doesn't meet the minimum required pressure head, calculate the penalty cost for all nodes with pressure less than the minimum. This is done for all scenario states (s) and time stages (t).
  - d) Calculate the total cost as the sum of the network cost and the penalty cost for all possible states and stages of design (over the whole range of possible scenarios).
  - e) Calculate the fitness of all future states.
- vi) Increment counter 1.
- vii) If counter is greater than the maximum generation, or if there is no improvement in the fitness function for certain specified generations, then the GA will converge. If so, store the detail of the best solution and go to step x—otherwise go to step 8.
- viii) Generate a new population
  - a) Select a best fit solution using selection scheme.
  - b) Perform the crossover for the selected population based on the probability of crossover (select two at a time to produce two offspring).

Keep the best solution from the previous population without crossover (offspring will be a copy of parents).

c) Mutate the offspring based on different mutation rates.

d) Store the new population.

ix) Repeat steps 5 to 7.

x) Store the details for the best solution WDS which performs under uncertainty.

#### **4.4 Hypothetical Test- GAFO Model**

##### ***4.4.1 Input Pipe Data and GA Parameters***

In this section, the GAFO model is applied to a hypothetical water distribution network. In this hypothetical test, spatial and temporal variation of demand is considered as an uncertain parameter. The hypothetical water distribution network layout following the critical spatial growth scenario is shown in Figure 4.4 (all other scenarios are tabulated in Table 4.1). A pipe length of 1000m and roughness of 130 is considered for all commercially available pipe diameters tabulated in Table 4.3. A 40-year design horizon with three-stage deployment is considered in this case study. The developed GA optimization model is applied to determine the least costly WDS solution that satisfies the future spatial and temporal growth demand while maintaining adequate pressure ( $H \geq 20\text{m}$ ) to determine the flexible WDS that can cope with the future spatial and temporal population growth in a more tractable manner.

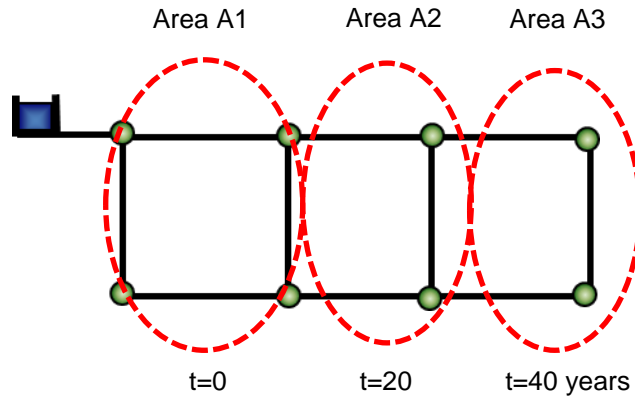

Figure 4.4 Typology of the hypothetical WDS

GAF0 is performed for a population of 50 individuals with 500 generations. Thus, the test includes a sample of 250,000 individuals (50 chromosomes in 500 generations). For the above typology, with all 11 pipes and 14 different commercially available pipe diameters, the solution space contains a total of  $14^{11}=4.05 \times 10^{12}$  different possible solutions at each stage of the design. This means a GAF0 sample represents around 0.000006% of the solution space. A step-by-step application of the developed model to this hypothetical case study and the simulation results are presented below. In addition, the model is also examined with different values of mutation rate of penalty factor with different selection and crossover methods.

#### **4.4.2 Input Spatial and Temporal Demand Growth**

The optimization is performed for a range of uncertain spatial and temporal demands. Uncertainty in nodal demand is examined at three discrete design stages (0, 20<sup>th</sup>, and 40<sup>th</sup> year). For this specific case, an increasing nodal



demand pattern with a range of uncertainty varying between 20L/s and 40L/s during the first stage, and 20 L/s to 60L/s during the second stage is used. The number of possible decisions and the state of demand at each design stage is shown in Table 4.1.

Table 4.1 Design stages and future growth

Simulation time step (i)	Design period t (years)	Number of Decision points (d)	Nodal demand in L/s (Q)	Spatial growth (each 1km <sup>2</sup> )	Total decision points
T <sub>0</sub>	0	1	[20]	A <sub>1</sub>	6
T <sub>1</sub>	20	2	[20, 40]	A <sub>2</sub>	
T <sub>2</sub>	40	3	[20, 40, 60]	A <sub>3</sub>	

The uncertainty representing the specified range of demand and spatial extent is modeled using the demand vectors. The scenarios representing the future demand growth for each design stage is represented as shown in Table 4.2. These demand vectors are input parameters of the GAFO model.

Table 4.2 Uncertain demand scenarios

Scenarios	Spatial extent Year 0-20 <sup>th</sup> -40 <sup>th</sup>	Nodal demand (L/s) Year 0-20 <sup>th</sup> -40 <sup>th</sup>
1	A <sub>1</sub> T <sub>0</sub> -A <sub>1</sub> T <sub>1</sub> -A <sub>1</sub> T <sub>2</sub>	20-20-20
2	A <sub>1</sub> T <sub>0</sub> -A <sub>1</sub> T <sub>1</sub> -A <sub>2</sub> T <sub>2</sub>	20-20-40
3	A <sub>1</sub> T <sub>0</sub> -A <sub>2</sub> T <sub>1</sub> -A <sub>2</sub> T <sub>2</sub>	20-40-40
4	A <sub>1</sub> T <sub>0</sub> -A <sub>2</sub> T <sub>1</sub> -A <sub>3</sub> T <sub>2</sub>	20-40-60

For the WDS to accommodate the future spatial and temporal demand growth shown in Table 4.2, this hypothetical test considers a platform approach

that uses parallel piping of the WDS. Parallel pipes will be deployed to the platform component when the future growth requires either spatial expansion or a capacity increase. In addition to the platform approach, flexibility is generated by staging the system deployment such that the WDS could change in response to different future change requirements, as shown in Figure 4.5.

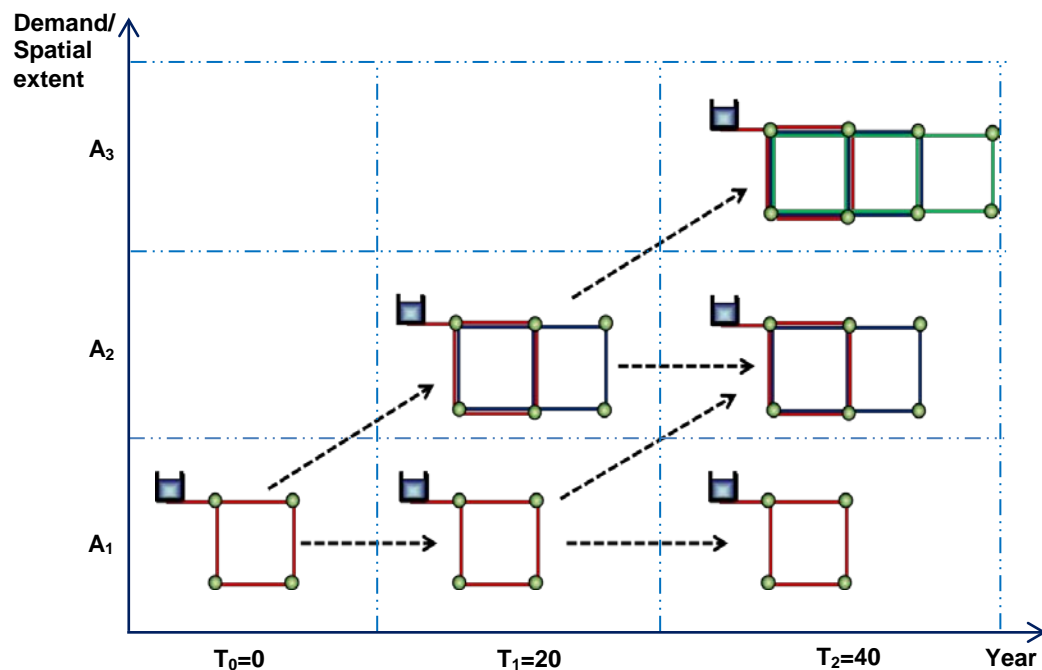

Figure 4.5 WDS spanning over the range of scenario

Figure 4.5 illustrates a WDS that follows the spatial and temporal growth of demand from A1 to A3 over 40 years. The layout is based on centralized designs, but a flexible approach where small incremental change in pipes is utilized to increase the capacity of the WDS so as to accommodate a variety of different future changes.

#### 4.4.3 Design Variable and GAFO Objective Function

Pipe diameter is the only design variable considered in the design process. Fourteen different commercially available diameters are used. The pipes range from a minimum pipe diameter of 25.4mm to a maximum pipe diameter of 609.6 mm. The list of these pipe diameters and their corresponding unit costs are shown in Table 4.3 (Prasad et al., 2004).

Table 4.3 Pipe cost

Diameter (mm)	Pipe cost (\$/m)	Diameter (mm)	Pipe cost (\$/m)
25.4	2	304.8	50
50.8	5	355.6	60
76.2	8	406.4	90
101.6	11	457.2	130
152.4	16	508	170
203.2	23	558.8	300
254	32	609.6	550

The GAFO minimizing cost objective function developed in this chapter (see Equation 4.8) is applied to optimize the WDS. The total cost is calculated using several input parameters such as: pipe length  $L=1000\text{m}$  cost function  $K * D_j^n$  values from Table 4.3; discount rate  $r= 3\%$ ; design stages  $t=\{T_0, T_1, T_2\}$  where each stage is  $\Delta t=20$  years; maximum future number of states at each period vary from  $s=\{1\}$  to  $s= \{1, 2, 3\}$ . In addition, the number of pipe links  $N=\{4, 6, 8\}$  is also an input parameter, but it follows the spatial growth and is decided by the optimizer at each decision stage.

#### 4.4.4 GAFO Process and Result Analysis

For each decision point, the GAFO generates an initial population using a random number generator that returns a pseudo-random integral number in the range from zero to Rand\_max. The integer code representing commercially available pipe diameters is shown in Table 4.4 (maximum integer representing the pipes is Rand\_max=13).

Table 4.4 Integer code representing the commercially available pipes

Diameter (mm)	Integer	Diameter (mm)	Integer
25.4	0	304.8	7
50.8	1	355.6	8
76.2	2	406.4	9
101.6	3	457.2	10
152.4	4	508.0	11
203.2	5	558.8	12
254.0	6	609.6	13

Hydraulic simulation is performed using WDS simulation software EPANET (Rossman, 2000). This software is used to compute the pressure head and supply at each node, as well as the discharge in each pipe under the specified input parameter. This model is coupled with the GAFO model. Thus, GAFO's randomly generated populations (WDS solution pipes) are used as an input for hydraulic simulation. This stage of GAFO computes the violation of performance due to changing input parameters (demand). The performance (i.e. pressure) of the string is analyzed for all possible demand cases. A constant penalty factor of 10,000 for the nodes that do not meet the minimum required

pressure (20m) is used. The performance variation in GAFO is computed using unique penalty functions developed in this chapter (Equation 4.10). The equation considers the performance variation for all 6 decision points formed by the different stages of the design  $t = \{0, 1, 2\}$  and future states  $s = \{1, 2, 3\}$ .

The sum of the penalty values is used to calculate the fitness of the population performing under a wide range of uncertainties. The performance of the GAFO is examined for both ranking and roulette wheel selection schemes. GAFO keeps a copy of the best parent population to the new offspring without crossover or mutation. This avoids the loss of the fittest population due to crossover and mutation processes. However, if there is a better population in subsequent generations, the GAFO replaces the best fit population from the previous generation with the best population from the later generation. One and two cut crossover methods with different probability of crossover are applied to examine the model. The GAFO simulation is also tested for different mutation rates. Successive generations are generated using similar steps. As the number of generations increase, the strings get closer together and converge to an objective function (least cost). Two termination criteria are used. The GA stops at a maximum of 500 generations, or if less than 0.01% improvement in the fitness value of the best chromosome is satisfied for 10% of the generation (50 generations). The progress of GAFO total cost function as a function of the number of generations for different selection schemes, crossover operators, and mutation probabilities is illustrated in Figure 4.6 to Figure 4.9.

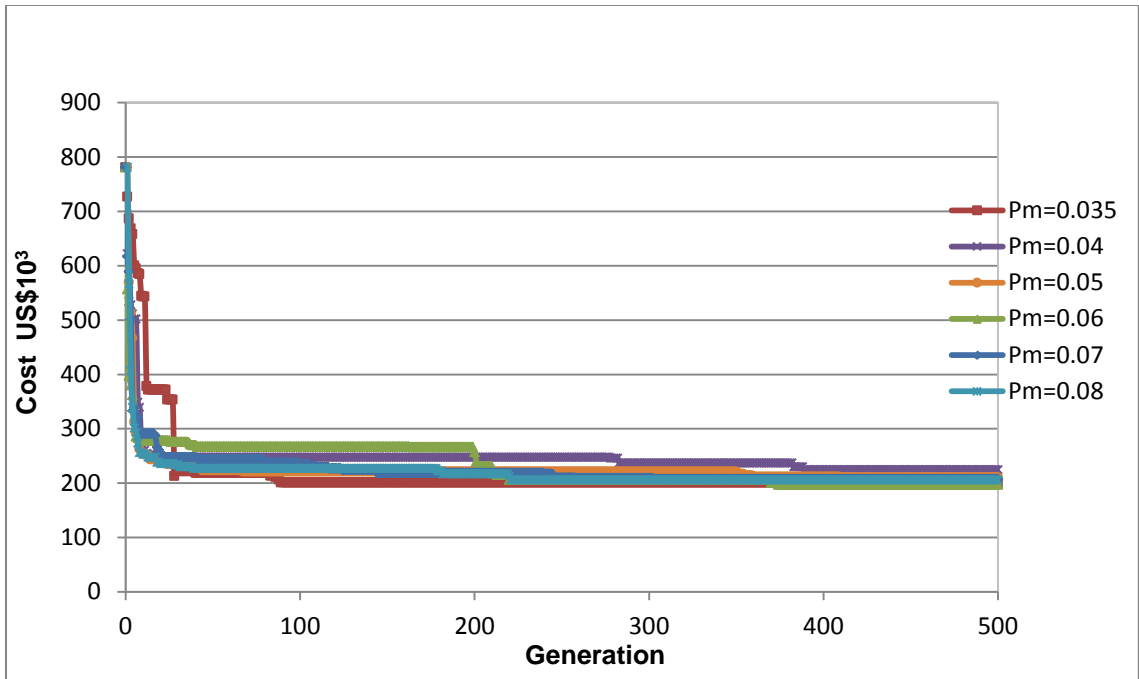

Figure 4.6 GAFO progression (roulette-wheel with one-point crossover)

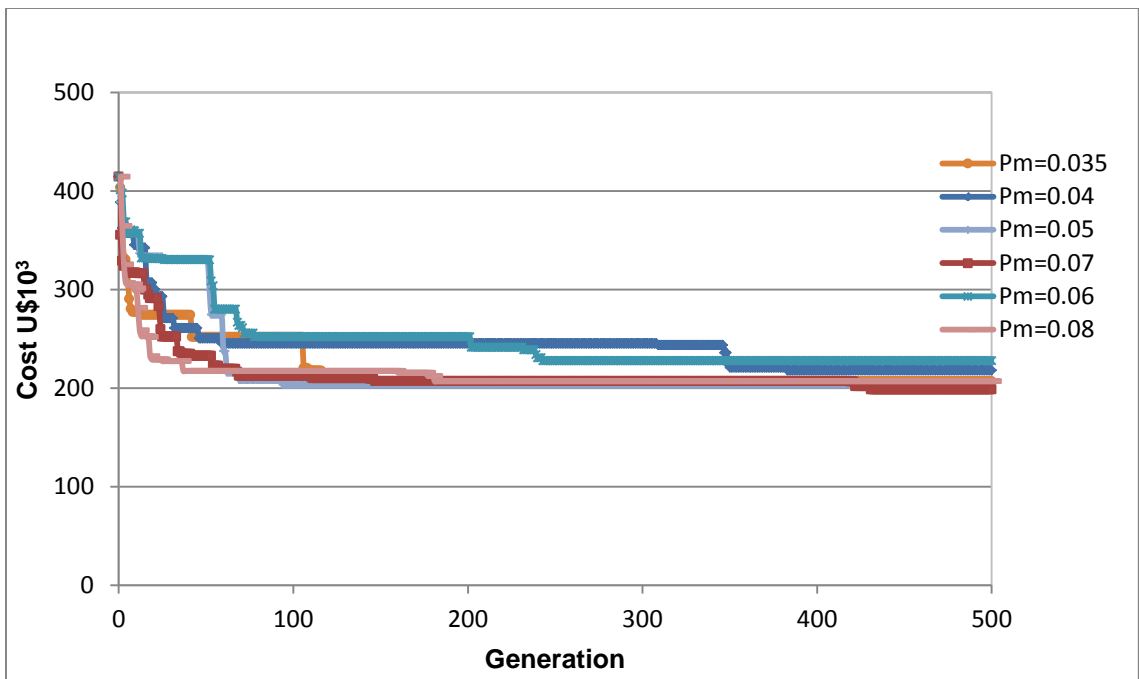

Figure 4.7 GAFO progression (roulette-wheel with two-point crossover)

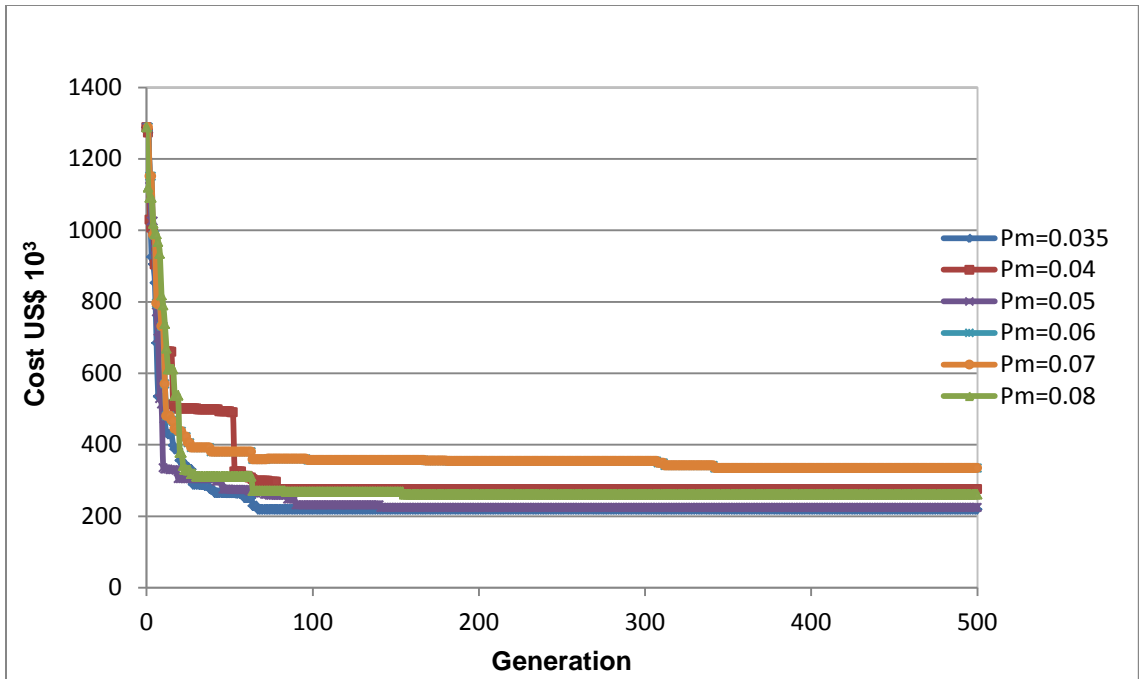

Figure 4.8 GAFO progression (ranking selection with one-point crossover)

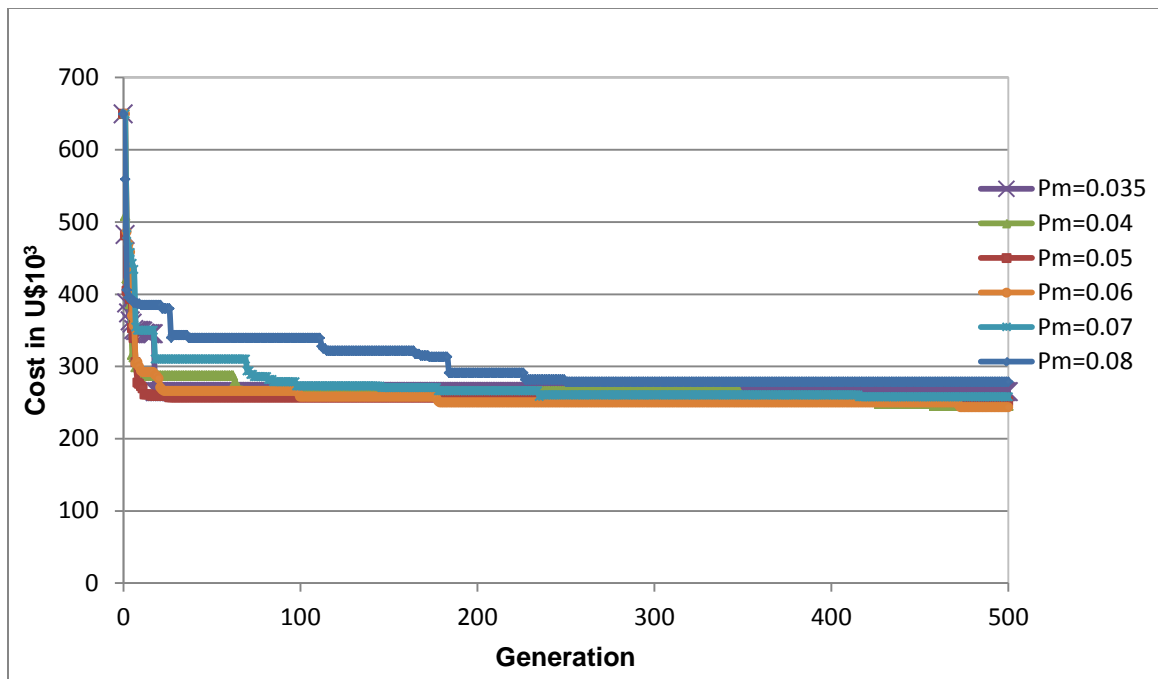

Figure 4.9 GAFO progression (ranking selection with two-point crossover)

The results in Figure 4.6 to Figure 4.9 show that the GAFO converges fast in the beginning generations and slower when coming close to the optimal solution (least cost WDS). This behavior is a general feature of GA optimization techniques; however, the convergence nature for different selection schemes and different mutation probability is different as shown in Figure 4.6 to Figure 4.9. GAFO's best fitness population costs for each mutation rate are selected and tabulated in Table 4.5. The minimum of the best fitness and average values are also plotted in Figure 4.10 and Figure 4.11 for comparison.

Table 4.5 Least cost for different selection scheme and crossover operator

Selection scheme	Crossover	Best fitness population for different mutation probability (cost in US\$)					
		0.035	0.04	0.05	0.06	0.07	0.08
Roulette-wheel	One-point	201047	224420	210213	197818	207672	206052
	Two-point	206761	217832	203331	227595	198637	206761
Ranking	One-point	219180	275419	224704	334506	334506	261424
	Two-point	264881	245378	251223	243109	257698	278788

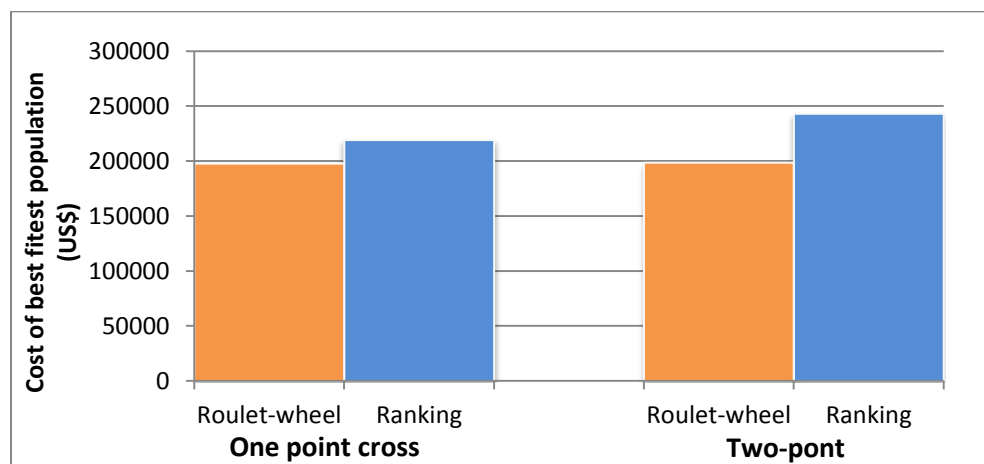

Figure 4.10 Comparison of the best fitness values



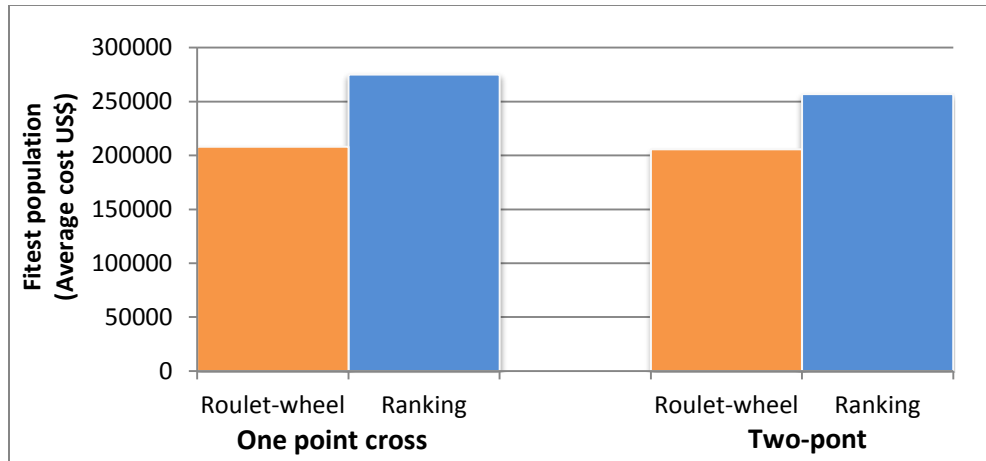

Figure 4.11 Comparison of the average fitness values

Comparison of GAFO results is done for both best and average fitness values. In both cases, the GAFO results with roulette-wheel selection scheme give the least cost value rather than the ranking selection scheme. The comparison of different crossover operations also show that GAFO simulation results for roulette-wheel selection using one-point crossover operator is better than the two-point crossover. The smallest cost for this test study (using roulette-wheel selection with one-point crossover) involves US \$58,000 if the future became scenario 1 ( $A_1T_0-A_1T_1-A_1T_2$ ), US \$9,632 for scenario 2 ( $A_1T_0-A_1T_1-A_2T_2$ ), US \$127,209 if scenario 3 ( $A_1T_0-A_2T_1-A_2T_2$ ) were to occur, and US \$197,818 if scenario 4 ( $A_1T_0-A_2T_1-A_3T_2$ ) comes to fruition. The optimal cost for each scenario is illustrated in stages of development following the future scenarios (see Figure 4.12). Scenarios 1 to 4 in Figure 4.12 represent the future spatial and temporal water demand growth described using the scenarios shown in Table 4.2.

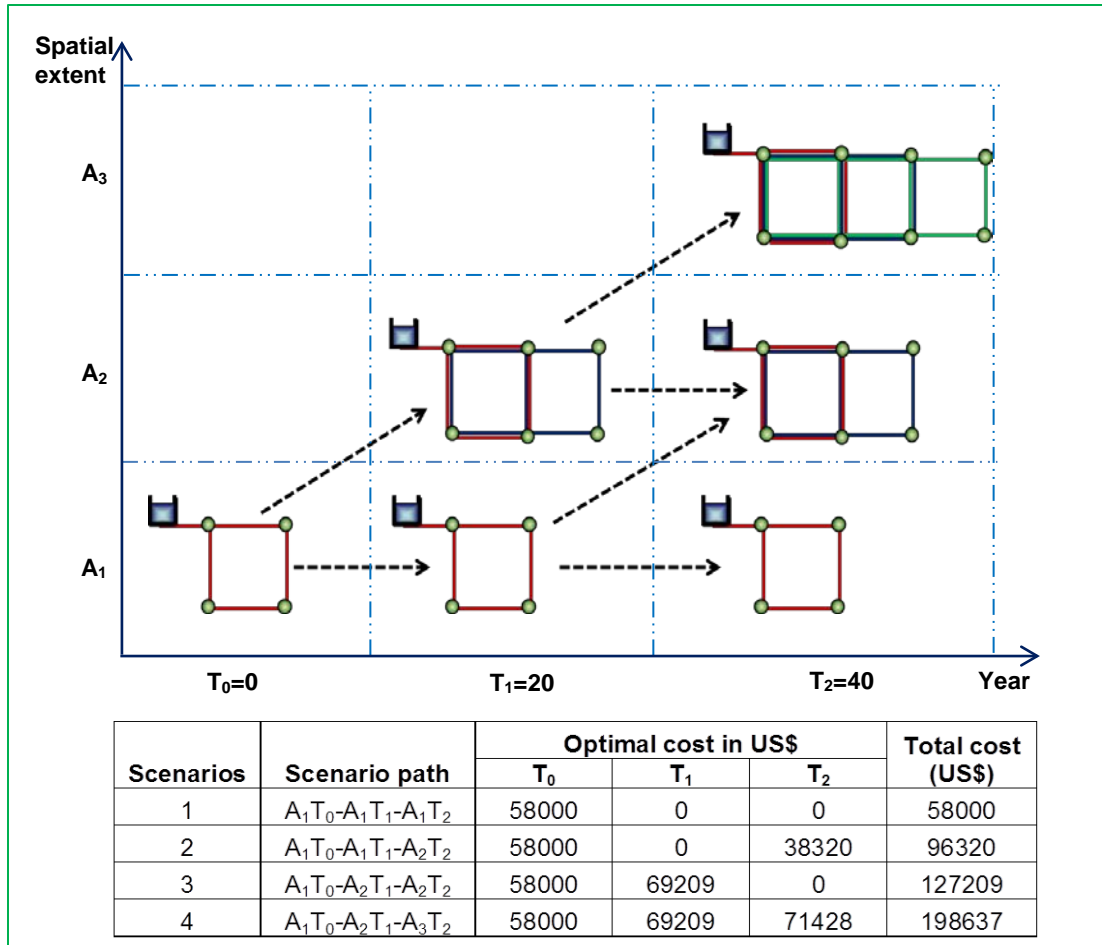

Figure 4.12 GAFO model results for the flexible WDS

In this optimization process, the GAFO embeds changeability which allows the WDS to evolve when there is a change requirement. To evaluate the value added by flexible design using the GAFO model, the output (NPV) of GAFO is examined with respect to a non-flexible WDS designed in a traditional way as a baseline. The traditional WDS design is performed for a critical scenario combination. However the design follows the same spatial expansion of the area as the flexible WDS. The cost values for the traditional design are shown in Table 4.6.

Table 4.6 Least cost for different scenarios

Scenarios	Scenario path	Optimal cost in US\$			Total cost (US\$)
		T <sub>0</sub>	T <sub>1</sub>	T <sub>2</sub>	
1	A <sub>1</sub> T <sub>0</sub> -A <sub>1</sub> T <sub>1</sub> -A <sub>1</sub> T <sub>2</sub>	205000	0	0	205000
2	A <sub>1</sub> T <sub>0</sub> -A <sub>1</sub> T <sub>1</sub> -A <sub>2</sub> T <sub>2</sub>	205000	0	4043	209043
3	A <sub>1</sub> T <sub>0</sub> -A <sub>2</sub> T <sub>1</sub> -A <sub>2</sub> T <sub>2</sub>	205000	22661	0	227661
4	A <sub>1</sub> T <sub>0</sub> -A <sub>2</sub> T <sub>1</sub> -A <sub>3</sub> T <sub>2</sub>	205000	22661	3088	230749

The comparison of the cost of WDS designed using GAFO (Figure 4.12) and using the traditional approach (Table 4.6) is done under different possible scenarios and plotted in Figure 4.13.

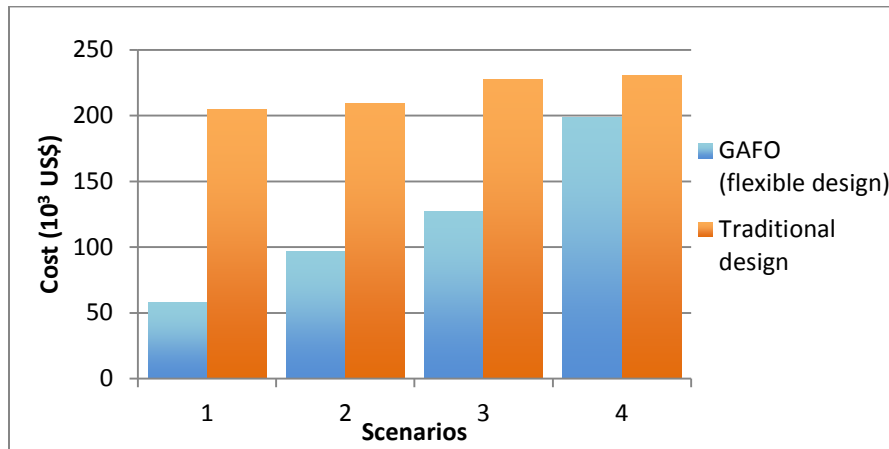

Figure 4.13 Traditional vs GAFO model result

The results in Figure 4.13 show that the improved cost of the flexible design ranged from 14% – 72% cheaper (for a range of four scenarios). Thus WDS designed using the GAFO model offer huge cost savings under possible future scenarios. The GAFO model maximizes the ability of the system to cope with uncertainties by enhancing a stepwise evolution of WDS over time.

#### 4.5 Conclusions: Optimization for Flexible WDS

In this chapter a new optimization model for the flexible design of WDS is developed. The proposed model is called the Genetic Algorithm based Flexibility Optimization (GAFO), and it allows for a stepwise evolution of WDS over time by embedding flexibility into the design stage. The GAFO model facilitates the development of flexible WDS that evolve with future change pressures and associated uncertainties over time and supports water system planners and designers to embed flexibility into WDS in a cost effective way.

The major steps of the proposed GAFO model involve: initialization of population, hydraulic simulation, uncertainty based fitness evaluation, and generation of new populations using reproduction. These four major steps are common to any GA optimization technique. Nevertheless, the proposed GAFO model has two major distinct features. First, the GAFO model maximizes flexibility by optimizing the objective function over a wide range of future uncertainties described by a scenario tree. The optimization process follows the scenario path and performs dynamic decision-making where the decision at each stage influences subsequent decisions. This means the minimization of objective function and fitness evaluation is done for the WDS solution to perform for all possible scenarios. Second, the GAFO model enhances changeability of the WDS. The optimization function maximizes the ability of the system to cope with uncertainties by considering the ease of change in terms of cost from one state

to another. This enhances a staged design which allows for the stepwise evolution of WDS over time.

The GAFO model is applied to a hypothetical case study in order to test different selection schemes, crossover operators, and mutation probability. The GAFO model performed well in terms of convergence for all cases. However, the comparison for the best and average fitness values shows that the GAFO performed better for roulette-wheel selection scheme with a one-point operator. In addition, the comparison between the GAFO model results and conventional non-flexible design shows that GAFO offers a cost savings of 14% to 72% for a range of four different scenarios.

In the next two chapters, the GAFO model will be applied to two real world case studies covering two basic options for the design of WDS. In Chapter 5, GAFO is applied to embed flexibility into a conventional centralized WDS. In Chapter 6, GAFO will be applied to a decentralized clustered WDS.

## **5 Flexibility of Centralized WDS: Case Study, Mbale, Uganda**

### **5.1 Introduction**

This chapter will compare the flexibility aspects of a centralized system that has been designed in a traditional approach to a centralized system that follows the flexible design approach developed in Chapters 3 and 4. In the first case, the design of the WDS is based on a scenario that attempts to meet the critical (maximum) temporal and spatial variation of demand. In the latter case, different options are considered that view the growth of the WDS as a gradual expansion, which involves staging and a parallel piping system.

The framework and optimization tool (GAFO) developed in this study has been applied to analyze and compare the flexibility aspects of the distribution system in Mbale, Uganda, taking into consideration the uncertainties associated with the changes in water consumption patterns and spatial growth in the town (see Figure 5.1). The case study will demonstrate the applicability of the developed framework and optimization tools for a centralized WDS that is planned for the future growth of a town.

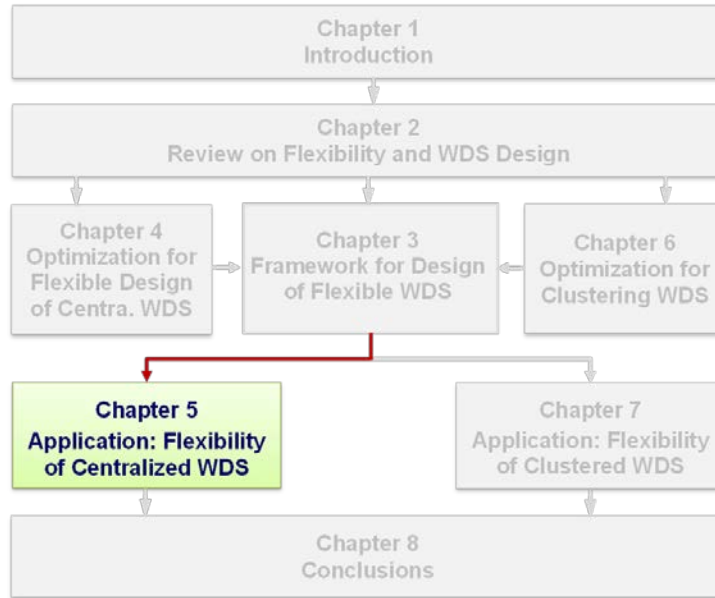

Figure 5.1 The interconnection of Chapter 5 with other chapters

## 5.2 Description of the Case Study Area

The town of Mbale is located at the foot of Mount Elgon in Eastern Uganda, 34° 10' east of the prime meridian and 1° 03' north of the Equator, lying 190 km northeast of Kampala (see Figure 5.2). The municipality occupies an area of approximately 24.35 km<sup>2</sup> (Ministry of Water and Environment, 2011). An analysis of the past development trends in Mbale reveals that the present level of urbanization is primarily attributable to increases in the population. The census records show that the population increased by 93% from 1980 to 1991, and by an additional 30% from 1991 to 2001. The recent growth has been accompanied by an increase in urban migration from the town's surrounding countryside to the town boundaries located in low-lying areas.

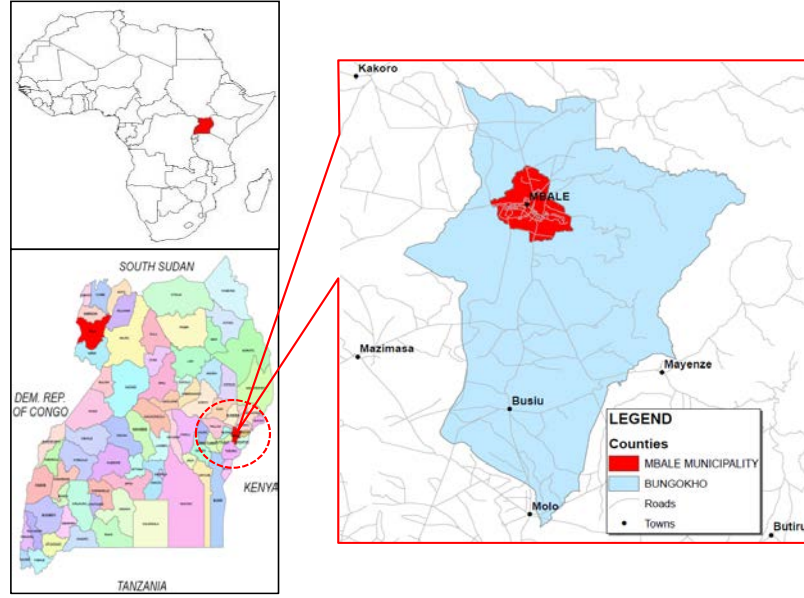

Figure 5.2 Geographic location of Mbale district

The current population within the municipality is projected to be 94,300 based on census results performed by the Uganda Bureau of Statistics, and Mbale's population growth rate was estimated at 3.6% annually (UBOS, 2011). The current state of the settlement and a categorical characterization of Mbale's water consumption are shown in Figure 5.3. Most of Mbale's development has occurred in an ad-hoc manner with no historical growth pattern. Within the central business district, the settlements are concentrated according to a linear pattern, while sub-standard settlements located in the peripheral areas lack any structure.



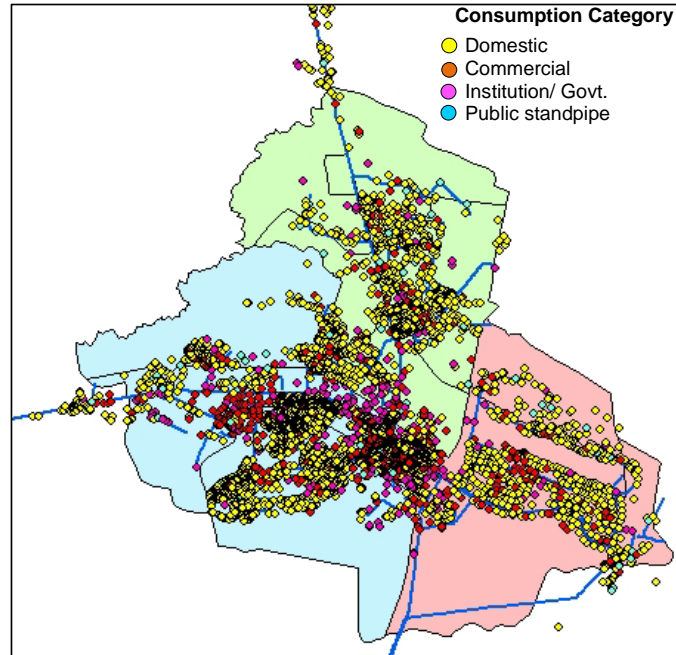

Figure 5.3 Mbale current settlement extent & water consumption category

### 5.3 Mbale Water Supply Challenges

According to the National Water and Sewerage Corporation (NWSC, 2012), the town's main sources of surface water include the Nabijo River, the Nabiyonga River, and the Manafwa River. The NWSC estimates that the maximum abstraction rate for the Nabijo and Nabiyonga Rivers is 5000 m<sup>3</sup>/d, while the Manafwa River can support 10,000m<sup>3</sup>/d. Due to seasonal variations, the water supply is becoming increasingly unreliable, resulting in a rationed supply during the dry season due to low source flows. Irregular supply is also exacerbated by the ageing pipeline infrastructure, which is subject to frequent bursts and leaks. When NWSC took over operation of the water supply of Mbale in 1973, the WDS contained about 85 km of pipeline. Since then, the amount of

the centralized infrastructure has ballooned to its current size of approximately 270 km. The WDS has grown by extending the existing centralized system to incorporate new settlements. This has resulted in some localized pressure deficits. Some of the limitations of the operational capacity, as mentioned by NWSC, can be attributed to an undersized transmission main and an underperforming treatment unit.

The existing challenges are expected to be amplified due to mounting population growth and urbanization pressures. Based on a growth rate of 3.6% (UBSO, 2011), the population of Mbale is expected to grow to 363,460 (more than three times the current population) by the year 2050. A summary of the population forecast from the years 2020 to 2050 is presented in Figure 5.4.

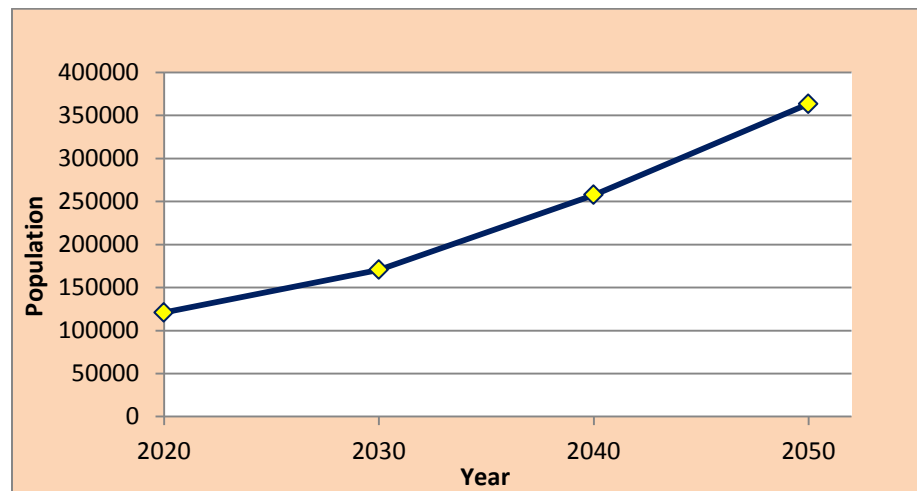

Figure 5.4 Population forecast for Mbale town from 2020 to 2050

It is anticipated that the municipality will grow spatially along the main roads and corridors that connect it to other major towns (Webster et al., 2012). Literature on urban economics suggests that changes in urban land areas (generally in the form of urban expansion or sprawl) are based on economic factors that include income, population size, agricultural land values, and transportation costs (McGrath, 2005). Currently, corridors of new developments in the town are found along major roads. In this study the anticipated growth along the main roads to the south and north of the municipality is considered. Figure 5.5 shows the future spatial extent of the town.

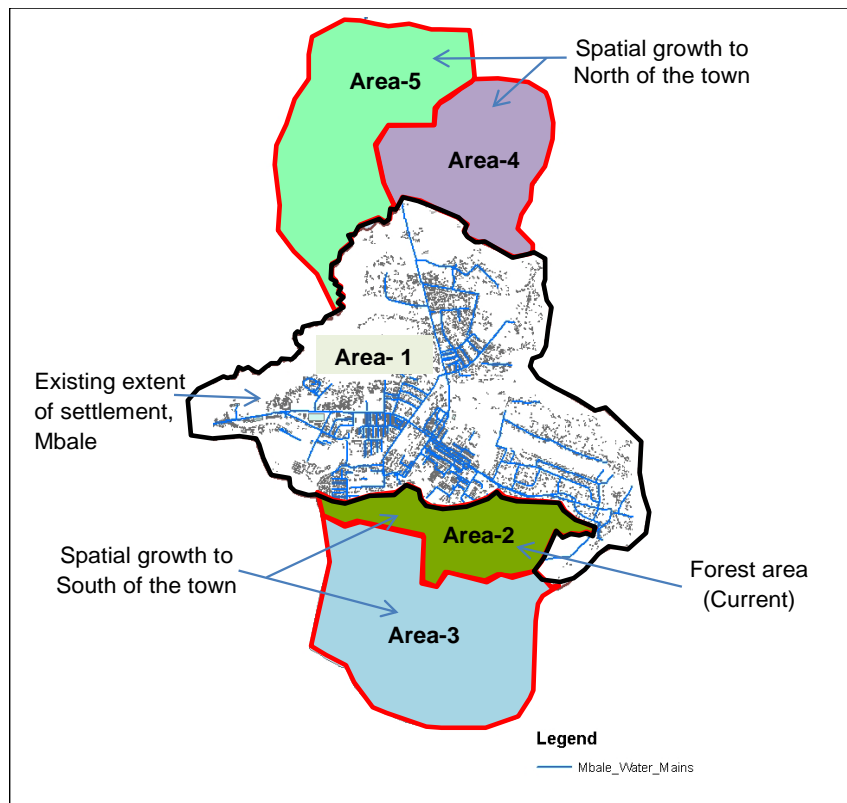

Figure 5.5 Spatial growth to the north and south of the town

Despite the challenges it poses, urbanization offers huge opportunities to implement a new paradigm for urban water systems. This is particularly the case in many emerging towns and villages like Mbale. Mbale is an emerging town—the area does not have mature infrastructure or governance structures, and urban planning has not yet happened, therefore providing a chance to implement new approaches to the provision of water to the community (Webster et al., 2012; Tsegaye et al., 2012). One of the opportunities is to develop a flexible WDS for the emerging areas.

#### **5.4 Development of Flexible Centralized WDS**

In this section, the developed framework and GAFO tool is applied to design a flexible centralized WDS for Mbale town. Comparisons are also made between a system designed based on traditional approaches (robust design) and a flexible WDS designed using the developed method in this chapter. A step-by-step application of the developed framework and the resulting comparisons are presented in the next subsections.

##### ***5.4.1 Uncertainty Description and Scenario Development***

In this case study of Mbale, two major uncertainties are considered in terms of the town's WDS: (i) future water consumption patterns, and (ii) the spatial growth of the town. The first uncertainty, water demand in the area, will vary depending on variations in population growth, socio-economic conditions, and physical water losses. It is therefore very important to take these future

variations into consideration. Through the use of scenarios, the possible future variations in water demand in Mbale are explored in this section. The second uncertainty involved in the future of the water system is the extent of the spatial expansion of the town due to unplanned growth. The town may grow in localized areas, though it may still follow linear extensions along roads; however, the extent of the expansion over time is uncertain. A consideration of these uncertainties at the design stage offers opportunities for the future water system to adjust to future growth at a reasonable cost, while considering potential options that may enable these uncertainties to provide value (Tsegaye and Vairavamoorthy, 2011). For the Mbale water system scenario, these two uncertainties are organized in a simple and tractable manner in which (i) the population grows continuously at a medium rate of 3.6%—which is associated with a range of possible spatial expansions—and (ii) per capita water demand either remains constant or increases with time. The following conditions are considered in determining the growth patterns the town may confront each year along the time horizon of 2020 to 2050.

- i) Year 2020: per-capita water consumption is 70 L/d; population density within the existing settlement area remains the same; population grows from 94,100 (in 2010) to 120,883 (in 2020), but the growth takes place in Area-2 (a forest area, which is expected to be a development site).
- ii) Year 2030: per-capita water consumption will either remain at 70 L/d or increase to 120 L/d due to increasing wealth; the town may either expand along the road to the south of the town center (Area-3) or remain the same

as that of 2020; population size will either remain the same as in 2020, or increase to 170,518 based on a growth rate of 3.6%; if there is a population increase, one-third of the additional population would settle in Areas-1 & 2, and two-thirds of the additional population would settle in Area-3 (see Figure 5.5).

iii) Year 2040: per-capita water consumption will either remain at 120 L/d or increase to 140 L/d; the town may either expand along the road to the north of the town (Area-4) or remain the same as in 2030; population size will either remain the same as in 2030, or increase to 257,664 (based on a growth rate of 3.6%); if the population grows, one-third of the additional population will settle in Areas 1, 2, & 3 and two-thirds of the additional population will settle in Area-4 (see Figure 5.5).

iv) Year 2050: per-capita water consumption remains at 140 L/d; the town may either expand north beyond Area-4 (to Area-5) or remain the same as in 2040; population size will either remain the same as in 2040, or will increase to 363,460 (based on a growth rate of 3.6%); if the population grows, one-third of the additional population will settle in Areas-1, 2, 3, & 4, and two-third of the additional population will settle in Area-5 (see Figure 5.5).

The above categories are used to develop the scenarios for this case study. Scenario development considers a 40-year design horizon with four-stage deployment. This means all scenarios will have four decision points (year 10th,

20th, 30th, and 40th). Based on the general future conditions suggested in each year, eight basic scenarios (development paths) can be developed as shown in Figure 5.6.

This scenario tree is used for describing the future possible conditions in a tractable manner and to create a decision node for flexible design that allows for stepwise evolution of the WDS to cope with the scenarios. The eight scenario combinations considered are listed in Table 5.1 and a detailed description of all scenarios is shown in Table 5.2.

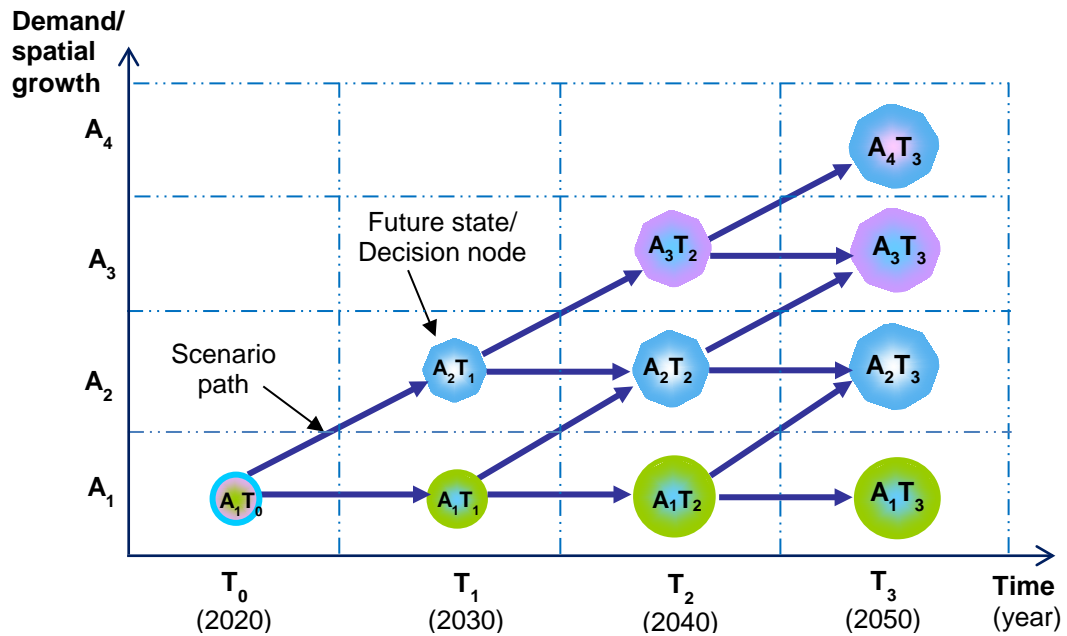

Figure 5.6 Scenario tree representing the future demand

Table 5.1 List of scenarios considered (for Mbale town)

Scenario No.	Scenario
1	A <sub>1</sub> T <sub>0</sub> - A <sub>1</sub> T <sub>1</sub> - A <sub>1</sub> T <sub>2</sub> - A <sub>1</sub> T <sub>3</sub>
2	A <sub>1</sub> T <sub>0</sub> - A <sub>1</sub> T <sub>1</sub> - A <sub>1</sub> T <sub>2</sub> - A <sub>2</sub> T <sub>3</sub>
3	A <sub>1</sub> T <sub>0</sub> - A <sub>1</sub> T <sub>1</sub> - A <sub>2</sub> T <sub>2</sub> - A <sub>2</sub> T <sub>3</sub>
4	A <sub>1</sub> T <sub>0</sub> - A <sub>2</sub> T <sub>1</sub> - A <sub>2</sub> T <sub>2</sub> - A <sub>2</sub> T <sub>3</sub>
5	A <sub>1</sub> T <sub>0</sub> - A <sub>1</sub> T <sub>1</sub> - A <sub>2</sub> T <sub>2</sub> - A <sub>3</sub> T <sub>3</sub>
6	A <sub>1</sub> T <sub>0</sub> - A <sub>2</sub> T <sub>1</sub> - A <sub>3</sub> T <sub>2</sub> - A <sub>3</sub> T <sub>3</sub>
7	A <sub>1</sub> T <sub>0</sub> - A <sub>2</sub> T <sub>1</sub> - A <sub>3</sub> T <sub>2</sub> - A <sub>3</sub> T <sub>3</sub>
8	A <sub>1</sub> T <sub>0</sub> - A <sub>2</sub> T <sub>1</sub> - A <sub>3</sub> T <sub>2</sub> - A <sub>4</sub> T <sub>3</sub>

Table 5.2 Description of the scenarios considered

Scenario no	Category	Year 2020	Year 2030	Year 2040	Year 2050
1	Population	120883	No change	No change	No change
	Demand	70 l/c.d			
	Expansion	Area-2			
	Population density	Additional pop. settle in Area-2			
2	Population	120883	No change	No change	170510
	Demand	70 l/c.d			120 l/c.d
	Expansion	Area-2			Area-3
	Population density	Additional pop. settle in Area-2			1/3 of the additional pop. grow within Area-1 & 2, and 2/3 expand to Area-3
3	Population	120883	No change	170510	No change
	Demand	70 l/c.d		120 l/c.d	
	Expansion	Area-2		Area-3	
	Population density	All additional pop. settle in Area-2		1/3 additional pop. grow within Area-1 & 2, and 2/3 expand to Area-3	



Table 5.2 (continued)

Scenario no	Category	Year 2020	Year 2030	Year 2040	Year 2050
4	Population	120883	170510	No change	No change
	Demand	70 l/c.d	120 l/c.d		
	Expansion	Area-2	Area-3		
	Population density	All additional pop. settle in Area-2	1/3 of the additional pop. grow with in Area-1 &2, and 2/3 expand to Area-3		
5	Population	120883	No change	170510	257664
	Demand	70 l/c.d		120 l/c.d	140 l/c.d
	Expansion	Area-2		Area-3	Area-4
	Population density	All additional pop. settle in Area-2		1/3 additional pop. grow in Area-1 &2, and 2/3 expand to Area-3	1/3 of the additional pop. grow within Area-1,2&3,and 2/3 expand to Area-4
6	Population	120883	170510	No change	257664
	Demand	70 l/c.d	120 l/c.d		140 l/c.d
	Expansion	Area-2	Area-3		Area-4
	Population density	All additional pop. settle in Area-2	1/3 of the additional pop. grow within Area-1 &2, and 2/3 expand to Area-3		1/3 of the additional pop. grow within Area-1,2 &3, and 2/3 expand to Area-4
7	Population	120883	170510	257664	No change
	Demand	70 l/c.d	120 l/c.d	140 l/c.d	
	Expansion	Area-2	Area-3	Area-4	
	Population density	All additional pop. settle in Area-2	1/3 of the additional pop. grow within Area-1 &2, and 2/3 expand to Area-3	1/3 of the additional pop. grow in Area-1,2 &3, and 2/3 expand to Area-4	
8	Population	120883	170510	257664	363460
	Demand	70 l/c.d	120 l/c.d	140 l/c.d	140 l/c.d
	Expansion	Area-2	Area-3	Area-4	Area-5
	Population density	All additional pop. settle in Area-2	1/3 of the additional pop. grow within Area-1 &2, and 2/3 expand to Area-3	1/3 of the additional pop. grow within Area-1,2 &3, and 2/3 expand to Area-4	1/3 of the additional pop. grow within Area-1,2, 3 &4, and 2/3 expand to Area-5

As an example, Figure 5.7 and Figure 5.8 illustrate the expected staged spatial growth patterns and the associated water demand of the town for scenarios 8 ( $A_1T_0$ -  $A_2T_1$ -  $A_3T_2$ -  $A_4T_3$ ).

				Area-4	Area-5
			Area-3	Area-4	Area-4
	Area-2	Area-3	Area-3	Area-3	Area-5
	Area-1	Area-2	Area-2	Area-2	Area-2
Area-1	Area-1	Area-1	Area-1	Area-1	Area-1
Base year (2011)	$T_0$ (2020)	$T_1$ (2030)	$T_2$ (2040)	$T_3$ (2050)	

Figure 5.7 Staged spatial growth for scenario  $A_1T_0$ -  $A_2T_1$ -  $A_3T_2$ -  $A_4T_3$

				$Q_5=9874$
			$Q_4=8134$	$Q_4=9247$
		$Q_3=3971$	$Q_3=5422$	$Q_3=6164$
	$Q_2=2036$	$Q_2=3968$	$Q_2=5417$	$Q_2=6159$
$Q_1=6426$	$Q_1=6426$	$Q_1=12524$	$Q_1=17100$	$Q_1=19440$
Base year (2011)	$T_0$ (2020)	$T_1$ (2030)	$T_2$ (2040)	$T_3$ (2050)

Figure 5.8 Water demand for scenario  $A_1T_0$ -  $A_2T_1$ -  $A_3T_2$ -  $A_4T_3$  (in  $m^3/d$ )

Figure 5.9 shows the future water demand values and the extent of spatial growth for all possible scenarios (combinations of A and T). These values represent the cumulative of all nodal demands of the area. The hydraulic simulation and optimization will be performed for those ranges of demands with their corresponding nodal demand values.

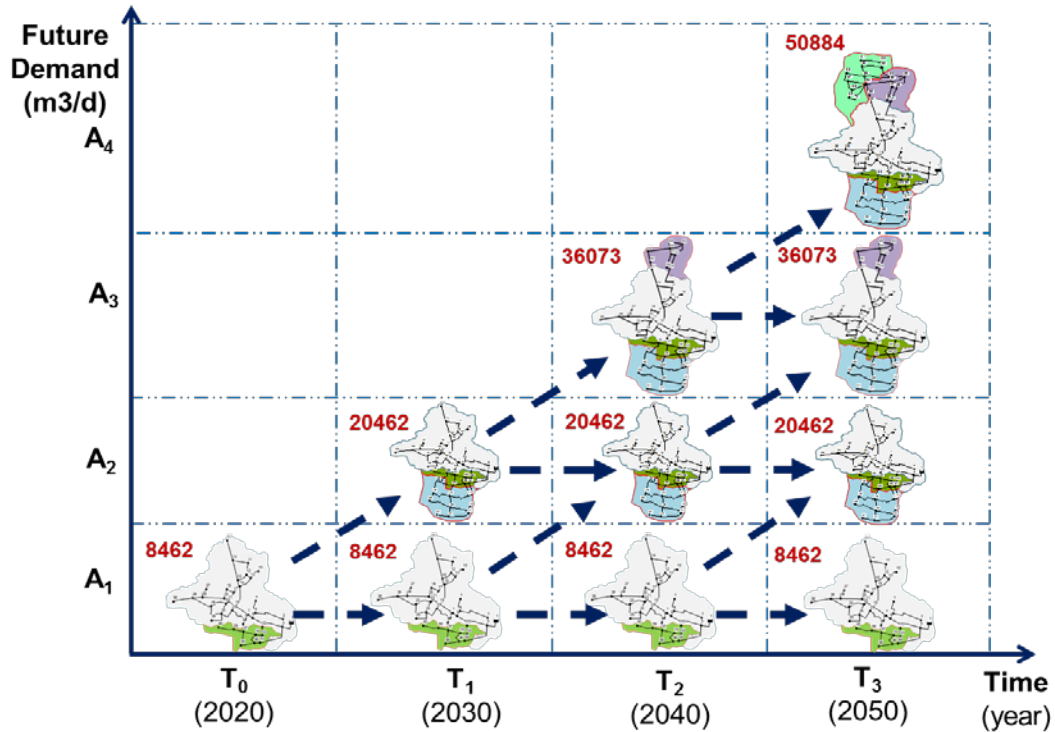

Figure 5.9 Spatial and temporal variation of water demand (A in m<sup>3</sup>/d)

#### 5.4.2 Design Options Considered

In this case study, a centralized design approach is followed to design WDS alternatives. The design of flexible centralized WDS employs the methodology and tools developed such that small incremental changes in pipes are utilized to increase the capacity of the WDS and to accommodate a variety of different future changes. This is done by adding parallel pipes to the main component when future growth requires either spatial expansion or a capacity increase (Kleiner, 1997). In addition, this approach allows for the implementation of WDS to be staged in a way that traces the urban growth trajectory more closely. The gradual stepwise development enables the expansion or deferral of WDS.

### 5.4.3 Generation of Flexibility

This chapter will compare the flexibility aspects of a centralized system that is designed in a traditional approach (WDS-1) and a centralized system that follows a flexible design approach (WDS-2) as developed in Chapters 3 and 4. In the first case, design of the WDS has been based on a scenario that attempts to meet the critical conditions. In the latter case, different options have been presented that consider the growth of the WDS as a gradual expansion, which involves staging and a parallel piping system. Thirteen different commercially available pipe diameters ranging from a minimum of 50.8mm to a maximum of 609.6mm are used. A list of the pipe diameters, their associated materials and laying costs is shown in Table 5.3 (Prasad et al., 2004; NWSC, 2012).

Table 5.3 Pipe material and laying costs

Diameter (mm)	Pipe Material (US\$/m)	Pipe laying cost (US\$/m)
25.4	2	3
50.8	5	3
76.2	8	4
101.6	11	4
152.4	16	4
203.2	23	7
254	32	7
304.8	50	10
355.6	60	20
406.4	90	20
457.2	130	25
508	170	25
558.8	300	25
609.6	550	25

The hydraulic simulation is performed using EPANET (Rossman, 2000). A 40-year design horizon with four-stage deployment is considered, and the range of uncertainties described by the scenario tree is used as an input for the flexibility optimization. The details of the design process for the two options and the results of the simulation are presented in the next subsections.

#### **5.4.3.1 WDS Design Alternative-1 (WDS-1)**

The conventional approach to the design of centralized WDS-1 is based on deterministic assumptions about the future. These involve the highest population growth and town expansion (a critical future scenario). It considers a design philosophy based on a fixed set of requirements, despite the fact that variations to the predictions may occur in the system's environment. In this case, the critical scenario-8 is used as an input with a staging design approach (see Table 5.2). The staging follows the spatial growth of the town such that Area-1 & 2 will grow by 2020, Area-3 by 2030, Area-4 by 2040, and Area-5 by 2050. This staged design offers the option of investment deferral at different stages of the design. Developments of the WDS-1 at various points of the town's expansion are shown in Figure 5.10. In this approach, as the population grows and new developments are established, the infrastructure is readily extended to provide the required additional capacity. This approach relies on providing an oversized infrastructure that will accommodate the highest flow predicted based on the maximum population and spatial growth. Thus, the huge cost incurred for the oversized infrastructure requirement and increased capacity may be

underutilized if the development path does not follow the expected maximum predictions.

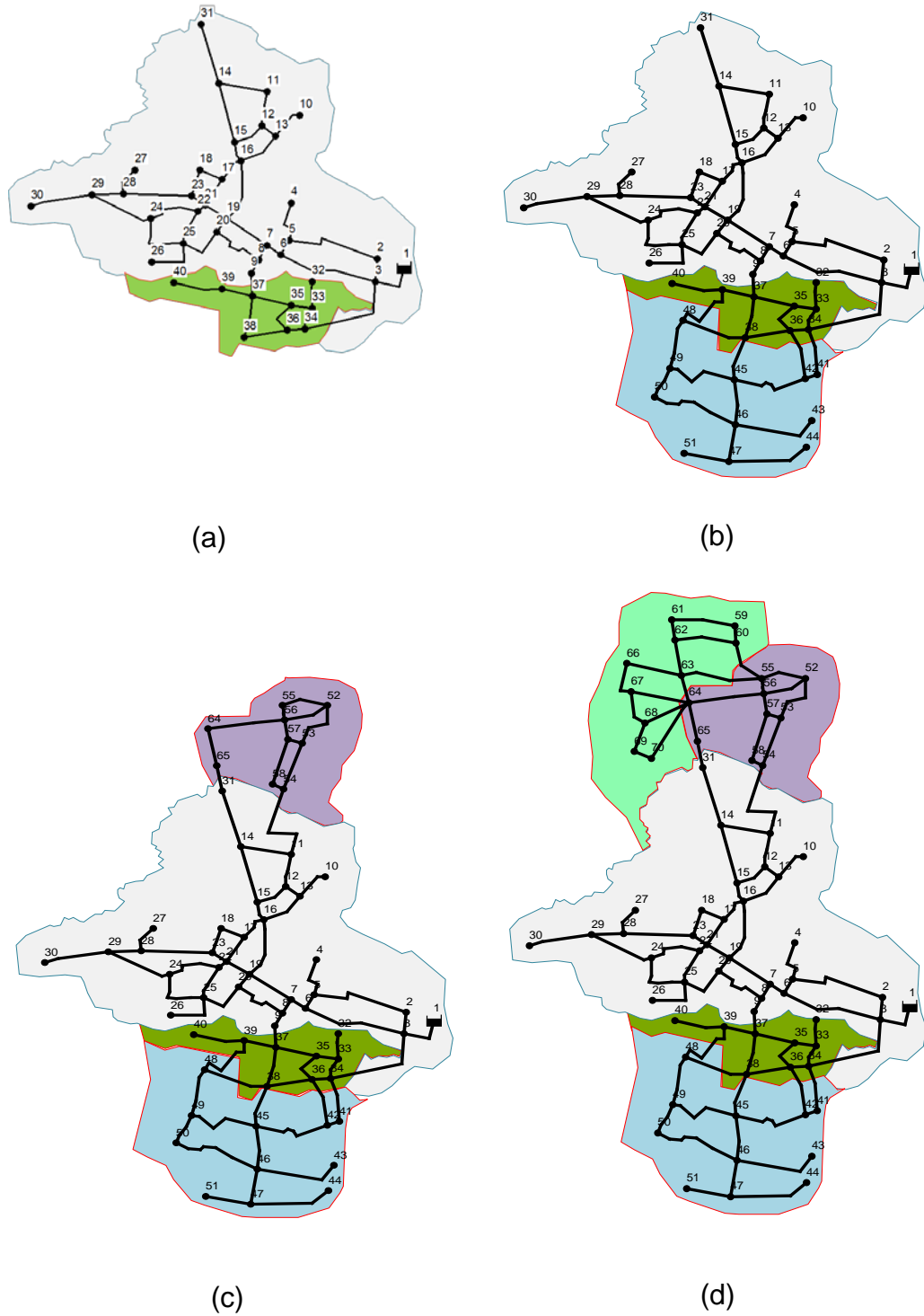

Figure 5.10 Mbale WDS-1 in year (a) 2020, (b) 2030, (c) 2040, (d) 2050

The stages of development from Figure 5.10 (a) to (d) represent the possible spatial growth of the town from the year 2020 to 2050. However, the scenario also describes possible growth patterns of the town. Thus, the optimized design is done for all scenarios, and the net present value (NPV) of the optimized centralized system that has been designed in a traditional approach for each scenario is tabulated in Table 5.4. These costs include the cost of reservoir and pipe material and pipe laying costs for the centralized WDS.

Table 5.4 The total cost of WDS-1 under all scenarios

Scenario No.	Scenario	WDS-1 (NPV in US\$)
1	$A_1T_0 - A_1T_1 - A_1T_2 - A_1T_3$	2,827,024
2	$A_1T_0 - A_1T_1 - A_1T_2 - A_2T_3$	3,285,148
3	$A_1T_0 - A_1T_1 - A_2T_2 - A_2T_3$	3,334,676
4	$A_1T_0 - A_2T_1 - A_2T_2 - A_2T_3$	3,401,237
5	$A_1T_0 - A_1T_1 - A_2T_2 - A_3T_3$	3,554,399
6	$A_1T_0 - A_2T_1 - A_3T_2 - A_3T_3$	3,620,959
7	$A_1T_0 - A_2T_1 - A_3T_2 - A_3T_3$	3,696,526
8	$A_1T_0 - A_2T_1 - A_3T_2 - A_4T_3$	3,836,503

#### 5.4.3.2 WDS Design Alternative-2 (WDS-2)

WDS-2 is designed as a centralized system that expands over time to accommodate uncertainty in demand and spatial growth. The design is performed using the developed GAFO model that increases the ability of the system to deal with a range of uncertainty (represented by the eight scenarios).

In this case, a parallel pipe design option is employed to provide the required flexibility. A step by step incremental in the capacity of the WDS traces the urban growth trajectory more closely without affecting the performance of the existing system. Four staged stages of development are also considered in the design process (year 2020, 2030, 2040, and 2050). Figure 5.11 shows WDS-2 in year 2020 and 2050.

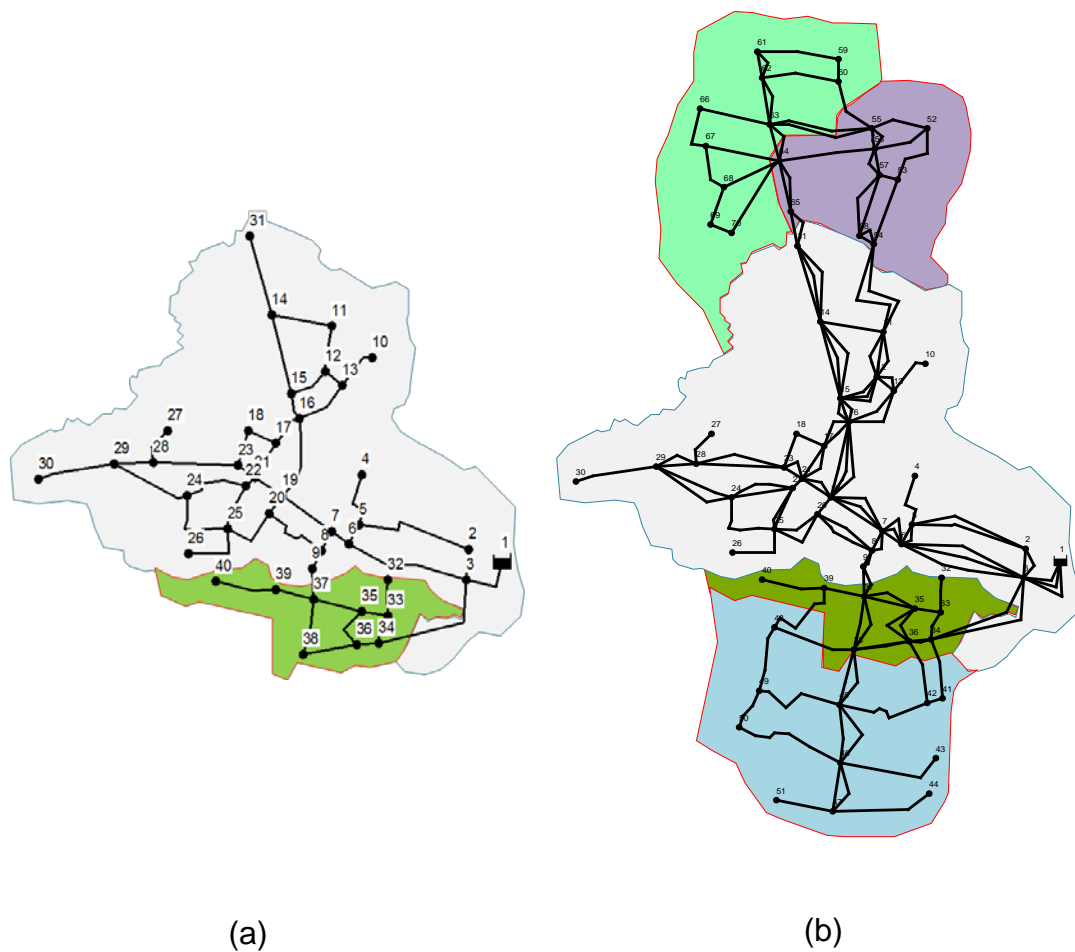

Figure 5.11 Mbale WDS-2 in year (a) 2020, (b) 2050



The WDS in Figure 5.11 (a) and (b) represent the possible spatial extent of the town in the year 2020 and 2050; however, there are also many other possible growth patterns of the town described by the eight scenarios. The optimal design is performed for all scenarios using the GAFO model, and the NPV is summarized in Table 5.5.

Table 5.5 The total cost of WDS-2 under all scenarios

Scenario No.	Scenario	WDS-2 (NPV)
1	$A_1T_0 - A_1T_1 - A_1T_2 - A_1T_3$	1,417,732
2	$A_1T_0 - A_1T_1 - A_1T_2 - A_2T_3$	2,067,335
3	$A_1T_0 - A_1T_1 - A_2T_2 - A_2T_3$	2,418,008
4	$A_1T_0 - A_2T_1 - A_2T_2 - A_2T_3$	2,590,987
5	$A_1T_0 - A_1T_1 - A_2T_2 - A_3T_3$	2,694,005
6	$A_1T_0 - A_2T_1 - A_3T_2 - A_3T_3$	3,014,265
7	$A_1T_0 - A_2T_1 - A_3T_2 - A_3T_3$	3,229,616
8	$A_1T_0 - A_2T_1 - A_3T_2 - A_4T_3$	3,696,553

The results show that the WDS designed using the GAFO model offers much larger cost savings, that range from 4% to 50% (for eight different scenarios), than the conventional centralized WDS (see Table 5.5 and Table 5.4). This shows the ability of the WDS-2 to change from one state to another state in a cost effective manner. However, cost alone does not guarantee flexibility. Thus, a post optimization analysis is performed below to assess the performance of the two systems with respect to flexibility.

#### **5.4.4 Flexibility Assessment and Decision Making**

The decision of what constitutes the best flexible WDS option is supported by a post optimization assessment of the system's capability to respond ( $C_{rs}$ ), and *capability to react* ( $C_{ra}$ ). These flexibility parameters are combined into the level of flexibility  $F_{opt}$  measuring parameters that represent the extent/ease with which a system can cope with uncertainties. A comparison is made using the regret principle based on the  $F_{opt}$  value of each WDS alternative, where the  $F_{opt}$  value is the weighted average value of  $C_{rs}$  and  $C_{ra}$ .

##### **5.4.4.1 Flexibility Assessment**

###### **5.4.4.1.1 Determination of the Capability to Respond**

$C_{rs}$  is the ratio of the range of responses  $U_{rs}$  to the optimized cost of change  $C_c$  for the WDS options under different scenarios. Figure 5.12 and Figure 5.13 show the  $U_{rs}$  and  $C_c$  of the different WDS options, respectively.

Figure 5.12, shows that the centralized conventional WDS-1, which is designed based on deterministic assumptions, is over-designed to absorb future changes and uncertainties. This means that the range of responses of the WDS-1 is larger than the range of responses of the WDS-2. However, this larger range also incurs greater costs ( $C_c$ ) than the WDS-2 designed using the developed GAFO model (as shown in Figure 5.13).

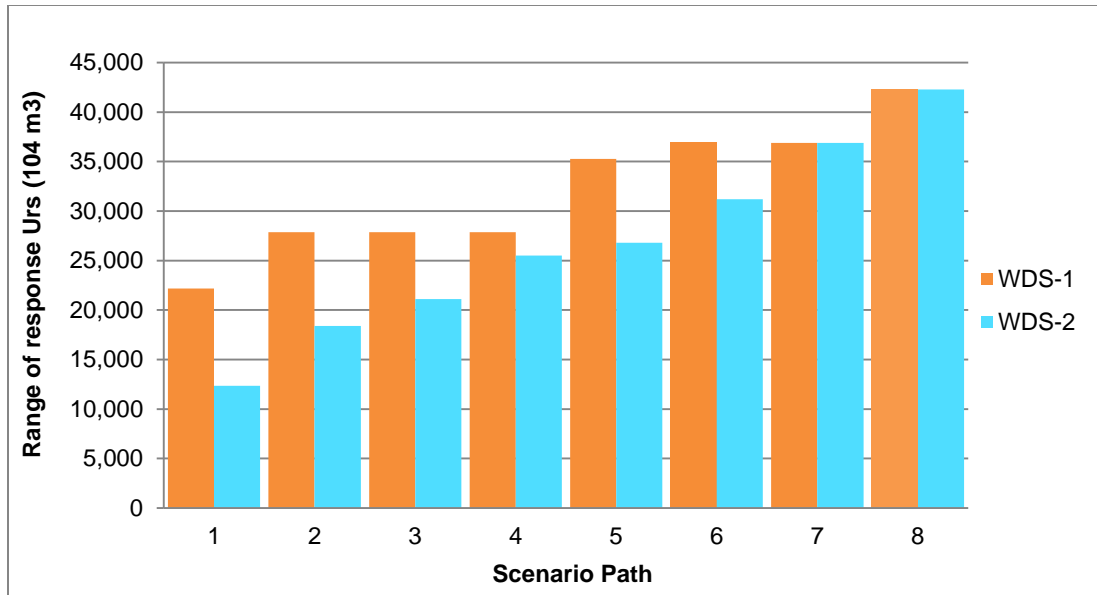

Figure 5.12 Range of response for WDS-1 and WDS-2

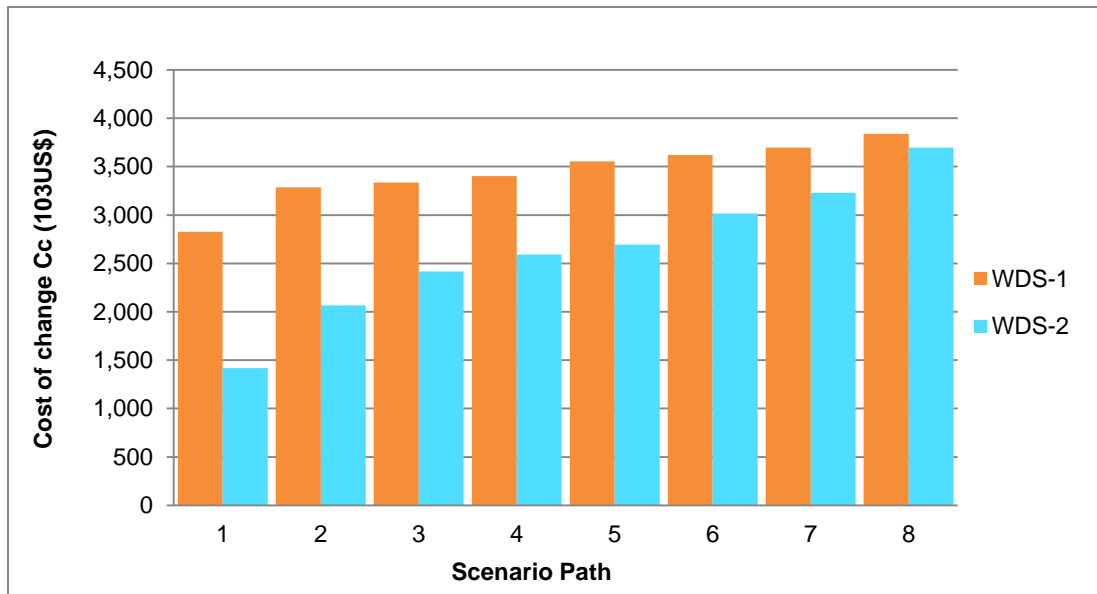

Figure 5.13 Cost of change for WDS-1 and WDS-2

The range of response  $U_{rs}$  values shown in Figure 5.12 and the cost of change  $C_c$  values shown in Figure 5.13 are used to calculate the capability to

respond  $C_{rs}$  of each WDS design under different scenarios, where  $C_{rs}$  is the ratio of  $U_{rs}$  and  $C_c$  (see Equation 3.1 in Chapter 3). A sample calculation is shown below for scenario-1 ( $A_1T_0$ -  $A_1T_1$ -  $A_1T_2$ -  $A_1T_3$ ). A similar approach is also followed for other scenarios;  $C_{rs}$  values are plotted in Figure 5.14.

$$C_{rs(WDS-1)} = \frac{U_{rs}}{C_c} = \frac{22167 * 10^4}{2827024} = 98.4 \text{ m}^3/\text{US\$}$$

$$C_{rs(WDS-2)} = \frac{12354 * 10^4}{1417732} = 87.1 \text{ m}^3/\text{US\$}$$

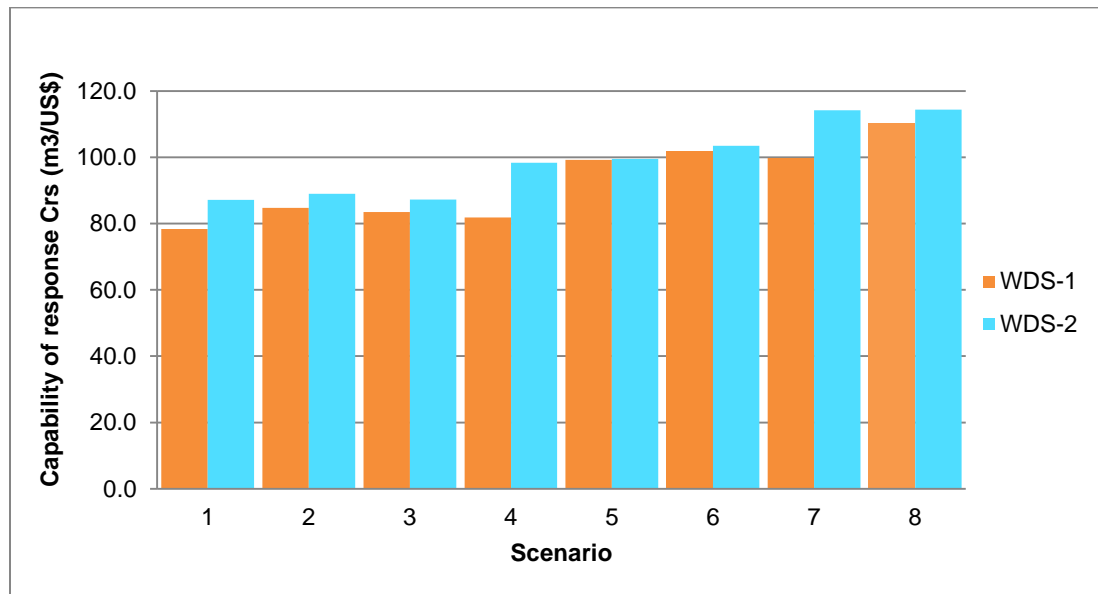

Figure 5.14  $C_{rs}$  value for WDS-1 and WDS-2

The values shown in Figure 5.14 depict that WDS-2, designed based on the principles of flexibility, is capable of responding to future scenarios. In contrast, WDS-1, designed based on conventional approaches, is able to respond to a smaller range of future uncertainties than the WDS-2 with the same

effort. This is because the WDS-1 incurs a large cost associated with the excess capacity of the system.

#### 5.4.4.1.2 Determination of the Capability to React

As discussed in Chapter 3, the  $C_{ra}$  value is represented by the ratio of the range of uncertainties that the WDS can handle ( $U_{ra}$ ) to the effort required to adapt ( $C_a$ ). The ranges of adaptation as well as the cost of adaptation values are plotted in Figure 5.15 and Figure 5.16. As shown in Figure 5.15, the centralized conventional WDS-1 is required to adapt to a small range, as it was over-designed. Because the range of reaction of the WDS-1 to the future changes is smaller than that of the WDS-2, the cost of adaptation to the smaller range is likewise smaller (see Figure 5.16).

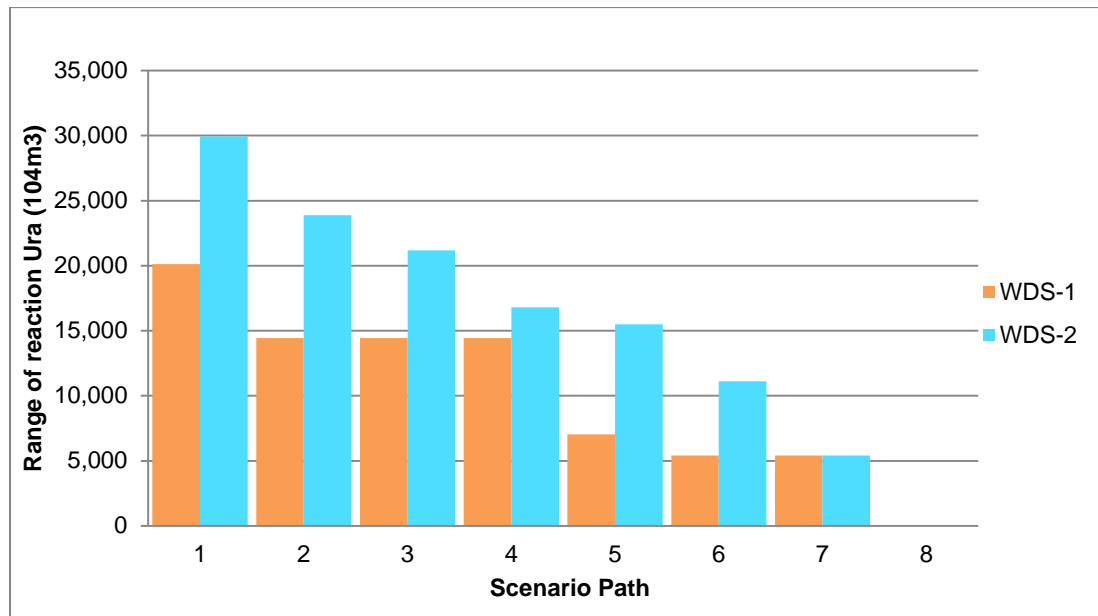

Figure 5.15 Range of adaptation for each design option

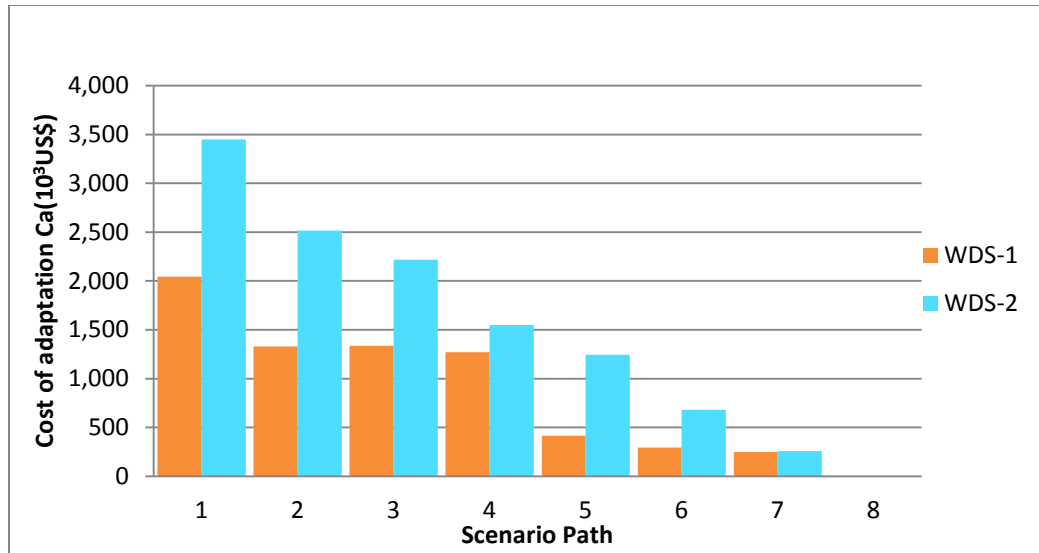

Figure 5.16 Cost of adaptation associated with each WDS design option

The values from Figure 5.15 and Figure 5.16 are used to calculate the  $C_{ra}$  value for each WDS. A sample calculation for scenario-1 ( $A_1T_0$ -  $A_1T_1$ -  $A_1T_2$ -  $A_1T_3$ ) is shown below. The  $C_{ra}$  for all decision paths is calculated in a similar manner, and the results are summarized in Figure 5.17.

$$C_{ra(WDS-1)} = \frac{U_{ra}}{C_a} = \frac{20129 * 10^4}{2044923} = 101.6 \text{ m}^3/\text{US\$}$$

$$C_{ra(WDS-2)} = \frac{29942 * 10^4}{3451123} = 115.3 \text{ m}^3/\text{US\$}$$

Even though the total cost of the reaction for WDS-1 is smaller, the results shown in Figure 5.17 depict that WDS-2, designed based on the flexibility principles, has a higher capability to react ( $C_{ra}$ ) to uncertain future scenarios. This is because the effort required to adapt to a unit range of future change is larger for the WDS-1 designed using the conventional approach than the WDS-2

designed using the GAFO tool. However, scenario 8 ( $A_1T_0$ -  $A_2T_1$ -  $A_3T_2$ -  $A_4T_3$ ) is based on the maximum possible future demand, and both WDS-1 and WDS-2 designed for this scenario are not required to adapt to any scenario.

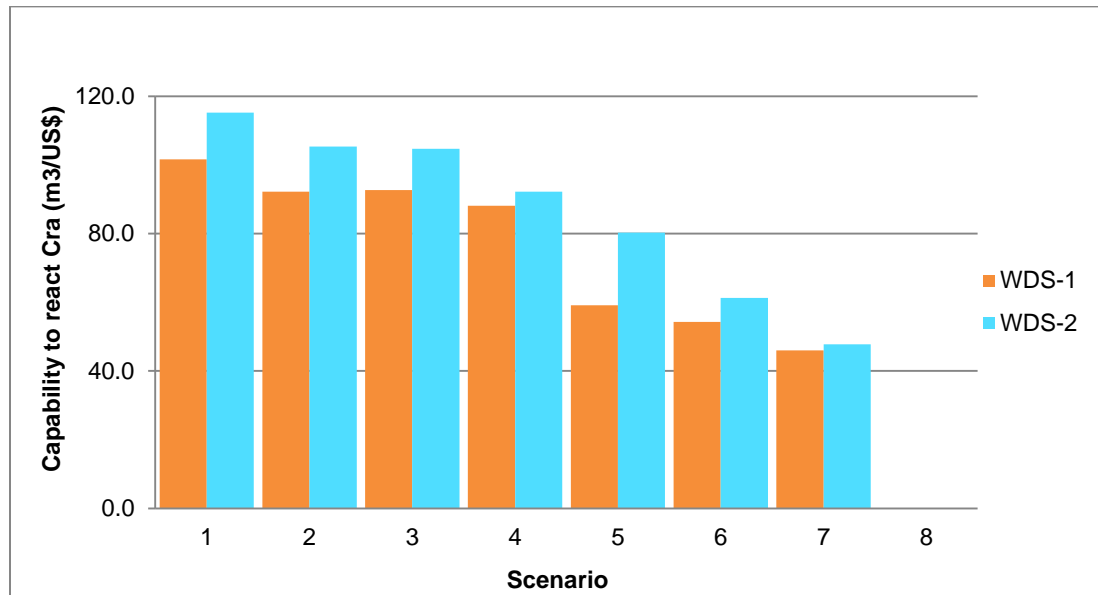

Figure 5.17  $C_{ra}$  values of WDS-1 and WDS-2

#### 5.4.4.1.3 Determination of the Level Flexibility

The flexibility of the different WDS options is determined using the  $F_{opt}$ . Larger  $F_{opt}$  values equate to a longer WDS lifetime flexibility under the specified uncertainties. Considering the same weighting for  $C_{ra}$  and  $C_{rs}$  ( $\omega_{rs} = \omega_{ra}$ ),  $F_{opt}$  will be determined using the equation below.

$$F_{opt} = 0.5C_{rs} + 0.5C_{ra}$$

Figure 5.18 shows  $F_{opt}$  values based on an equal weighting factor for  $C_{ra}$  and  $C_{rs}$  for each WDS option under different scenarios.

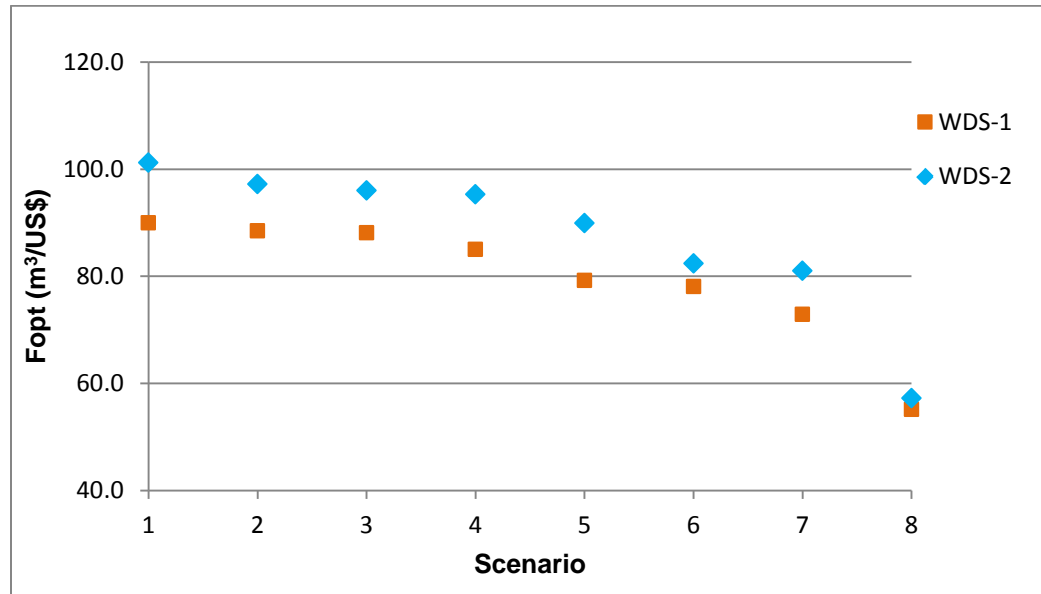

Figure 5.18 The optimal flexibility value for each WDS option

The results in Figure 5.18 show the flexibility of both WDS-1 and WDS-2. The figures illustrate that WDS-2 has a high flexibility value and performs better under all scenarios than WDS-1. The results also show that the value of flexibility for the system designed using GAFO (WDS-2) is greater for the smaller scenarios than for the worst scenario (H). This is because the high value of flexibility is delivered if the future scenarios turn out to be better, where the value of flexibility is determined by uncertainties. If the future condition becomes the worst scenario, the value added by the flexibility will be smaller. The regret associated under each scenarios and the decision for selection is presented in the next subsection.



#### 5.4.4.2 Choosing Between WDS Design Options

Flexibility-based decision making should follow a general quantitative approach to settling on a decision that is suitable for a wide range of future conditions. In this case study, a *minimax* regret approach, which minimizes the future regret associated with the present decision, has been implemented to choose between design options. The regret is represented by the opportunity loss with respect to the  $F_{opt}$  value. A sample calculation of the regret associated with the different options under scenario  $A_1T_0$ -  $A_1T_1$ -  $A_1T_2$ -  $A_1T_3$  is shown below.

$$f_{R(WDS1)} = \max\{F_{opt(i,j)}\} - F_{opt(i,j)} = 101.2 - 90.0 = 11.2$$

$$f_{R(WDS2)} = 101.2 - 101.2 = 0$$

The regret for each alternative under all other scenarios is calculated using the same approach, and the results are summarized in Table 5.6 below.

Table 5.6 Regret associated with the different design options

Scenario no.	Scenario	Regret with respect to $F_{opt}$ (m <sup>3</sup> /US\$)	
		WDS-1	WDS-2
1	$A_1T_0$ - $A_1T_1$ - $A_1T_2$ - $A_1T_3$	11.2	0.0
2	$A_1T_0$ - $A_1T_1$ - $A_1T_2$ - $A_2T_3$	8.7	0.0
3	$A_1T_0$ - $A_1T_1$ - $A_2T_2$ - $A_2T_3$	7.9	0.0
4	$A_1T_0$ - $A_2T_1$ - $A_2T_2$ - $A_2T_3$	10.3	0.0
5	$A_1T_0$ - $A_1T_1$ - $A_2T_2$ - $A_3T_3$	10.7	0.0
6	$A_1T_0$ - $A_2T_1$ - $A_3T_2$ - $A_3T_3$	4.3	0.0
7	$A_1T_0$ - $A_2T_1$ - $A_3T_2$ - $A_3T_3$	8.1	0.0
8	$A_1T_0$ - $A_2T_1$ - $A_3T_2$ - $A_4T_3$	2.1	0.0
<b>Maximum regret</b>		<b>11.2</b>	<b>0.0</b>
<b>Minimax regret</b>		<b>WDS-2</b>	

Based on the *minimax* regret analysis shown Table 5.6, the WDS-2 design option, which involves step by step incremental in the capacity of the WDS by adding parallel pipes has a lower regret under different scenarios when compared to the conventionally designed system (a difference of 11.2m<sup>3</sup>/US\$). In addition, the results of this application indicate that the flexibility framework was able to generate a more flexible WDS-2 that was 4%–50% less expensive than a conventionally designed system when compared against several future scenarios. Thus, this system offers a longer lifetime flexibility value and is therefore considered the superior alternative. The choice of the decision path for the preferred option is based on current knowledge and is not a one-step decision. It can be changed based on how future uncertainties evolve and unfold. In addition, the system allows numerous stage deployments during the course of its lifecycle to embed different options that allow the system to evolve through time.

## **5.5 Conclusions: Flexibility of Centralized WDS**

This chapter has applied the developed flexible GAFO WDS design framework and tool to take into account future uncertain conditions in the real case study of a WDS in Mbale, Uganda.

In this case study of Mbale, two major uncertainties have been considered in terms of the town's WDS: (i) future water consumption patterns, and (ii) the spatial growth of the town. The first, water demand in the area, will vary

depending on variations in population growth, socio-economic conditions, and physical water losses. The second uncertainty involved in the future of the water system is the extent of the spatial expansion of the town due to unplanned growth. The town may grow in localized areas, though may still follow linear extensions along roads; however, the extent of the expansion over time is uncertain.

This chapter organized future uncertainties in Mbale into eight possible scenarios using a scenario tree method, and an optimization was performed under those developed scenarios. The results of this application showed that the flexibility framework was able to generate a flexible staged design that was cheaper than a conventionally designed system when compared against several future scenarios. The improved costs of the flexible design ranged from 4%–50% cheaper for a range of eight scenarios. In addition, the application highlighted that the flexible design has a lower regret under different scenarios when compared to the conventionally designed system (a difference of 11.2m<sup>3</sup>/US\$).

The flexible WDS offers the ability to cope with new, different, or changing requirements and is therefore considered the superior alternative. This chapter finally concludes that small incremental in WDS capacity provides an opportunity in adapting to future change and uncertainties in a cost effective manner.

## 6 Optimization Model for Clustering WDS in Emerging Area

### 6.1 Introduction

This chapter discusses the development of an optimization model that divides future growth of urban area into clusters to allow for the provision of flexible, modular decentralized water distribution system (WDS).

Decentralized systems are small sub-systems (clusters) that have large degree of autonomy and could be adapted to future changes with low effort and without affecting the performance of the entire system (Böhm et al., 2011; Kluge and Libbe, 2006). This modular diversity exponentially increases the amount of possible configurations that can be achieved for urban water systems from a given set of inputs.

Decentralized/clustered WDS can be implemented in an incremental fashion, which reduces investment costs and makes the project easier to manage (Wang et al., 2008; Weber et al., 2007). In addition, decentralized systems allow for WDS to be staged in a way that traces the urban growth trajectory more closely. According to Wang et al., (2008) the gradual stepwise development of decentralized systems enables the expansion of urban water systems that follows the spatial growth, and hence embeds flexibility to WDS.

Besides flexibility there are additional reasons that support the shift from conventional centralized WDS to decentralized clustered WDS. Considering increasing global change pressures, there are increasing concerns about whether conventional centralized water systems will be able to manage scarcer and less reliable water resources in a cost efficient manner (Valerie, 2008). In order to cope with these challenges, future urban water systems are likely to be more decentralized than conventional systems because water reuse requires reducing the distance between water users and treatment locations. This minimizes energy demand and infrastructure costs and maximizes the recovery of heat energy if water is used close to where it is generated (Cornel et al., 2011; Newman, 2001; Bieker et al., 2010; Chen and Wang, 2009; and Verstraete et al., 2009).

In addition decentralized systems provide a better capacity to reduce the risk associated with WDS contamination through biological or chemical ingress as well as malicious attacks such chemical, biological and radiological agent. This is because decentralized units are small and independent units where the effect associated with water contamination and malicious attacks will be contained within a cluster. However in case of centralized WDS any contaminant ingress and malicious attack could propagated to the whole systems.

There are two major challenges for the flexible design of decentralized and clustered WDS. First, currently no methods exist which guide planners in how to cluster decentralized urban water systems. Second, work is still missing that demonstrates that the increased flexibility offered by decentralized/clustered. This chapter addresses the first challenge and develops a new clustering methodology that allows for better clustering of urban water systems for emerging areas into small and adaptable clusters that maximizes the performance benefits of the systems (recovery of resources, etc.).

The proposed clustering/decentralization approach is based on two major optimization principles: minimization of the distance from source to consumer by assigning demand to the closest source center, and maximization of the homogeneity within the cluster by reducing the variation in population density, land use, socio-economic level, and topography. Compared to conventional centralized WDS, modular and clustered WDS provide greater flexibility. This clustering approach is part of the framework for the flexible design of WDS presented in Chapter 3, where it is presented briefly (see Figure 6.1). Application of the clustering optimization model to real world case studies is presented in Chapter 7.

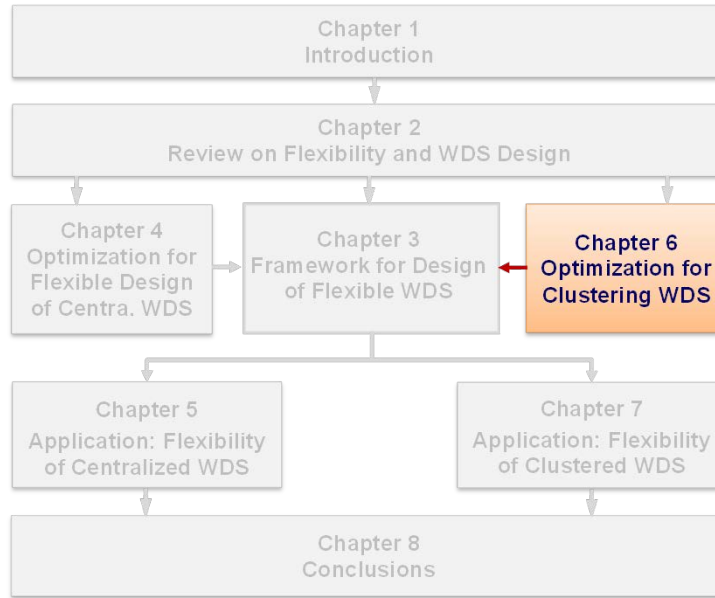

Figure 6.1 The interconnection of Chapter 6 with other chapters

## 6.2 The Proposed Clustering Method for Emerging Areas

In this study clustering of the water system is proposed for the emerging areas. The proposed clustering methodology is based on two major principles: (i) minimization of the distance from source to consumer by assigning demand to the closest source center, and (ii) maximization of the homogeneity within the cluster by reducing the variation in population density, land use, socio-economic level, and topography. In order to define an optimal cluster boundary that minimizes source-demand distance and maximizes the homogeneity within the cluster, this research considers different parameters such as the location of water sources (surface water and ground water), topography (Digital elevation-DEM), spatial and temporal distribution of population, land use characteristics, and the socio-economic status of the area (GAUFF, 2011). These parameters

are used to define source-demand distance, intra-cluster demand, and topographic homogeneity of the study area (Herrera et al., 2010).

### **6.2.1 Source-Demand Distance**

The sources-demand location plays an important role in reducing the transport of water and associated investment cost. Assigning demand to the nearest source location reduces the effort to collect and distribute water to the users. This reduces the cost of the pipe network (due to reduced pipe size/length) required to collect and distribute water and the energy needed for pumping long distances. Minimizing the transportation distance also increases the compactness of pipe and sewer networks, thereby maximizing resource conservation and minimizing losses (i.e. leakage). In addition, it improves the potential to reuse and recycle wastewater to the proximity within the cluster.

### **6.2.2 Intra-cluster Demand and Topographic Homogeneity**

Understanding topography and water consumption is extremely important for optimization of investment and operation costs and maximization of resource efficiency. Traditionally, analyses were performed for large regions which involved a variety of topography, land use, and associated demand. However, with the advent of clustering, the study of the behavior of smaller areas has become necessary to allow for the creation of uniformity within the clusters. The uniformity should consider topography, population distribution, land use, and socio-economy within a cluster. The population distribution, land use and socio-



economic parameters are aggregated into a spatio-temporal demand distribution of the area. Intra-cluster demand homogeneity is used as one of the parameters to minimize the effort required to move water and wastewater. Intra-cluster homogeneity is the measure of the similarities or dissimilarities between parcels of the same cluster.

Different demand areas require different infrastructure capacity. Clustering of large and small demand areas together involves huge variations in consumption which can cause larger pressure fluctuation than areas with similar demand distribution. This causes additional efforts to supply and manage water and wastewater in the area. For example, areas with urban agriculture have different demand patterns than industrial or residential areas. Thus, maximizing the similarities by clustering residential and agricultural areas separately will improve the required efforts compared to if they were clustered together. The clustering of different land uses into different clusters will ensure multiple uses of water by cascading it from higher to lower-quality needs and through reclamation treatments for a return to the supply side of the other cluster. Water used by residential clusters can be re-used by industrial or agricultural clusters. Demand based clustering also improves the ability to implement relevant technology (i.e. water treatment and wastewater reuse recycling schemes) within a homogeneous cluster. This also allows better control of small and homogeneous cluster units.

Topography is the other major factor which affects the flow of water and wastewater. Areas with similar topographic characteristics reduce costs associated with infrastructure and pumping of water and wastewater in the area. However, large variations in topography increase the effort required to collect and supply water, and reuse, recycle, and discharge wastewater. For example, WDS in areas with large topographic variations cause large pressure fluctuations and require a large amount of energy for pumping, as well as a large system capacity to satisfy the required level of service. Thus, partitioning WSS based on improved intra-cluster topographic homogeneity will reduce the costs associated with water system investment and operation (energy). It allows for improved resource efficiency by encouraging reuse and recycling of wastewater within the cluster and by minimizing leakage (water loss) through reduced pressure variations.

The starting point of this study's proposal to cluster WSS is to take into account all the input parameters of the study areas. This involves the location of water sources (surface water, groundwater, and stormwater collection points), topography, spatio-temporal population growth, demand pattern, land use characteristics, socio-economic status, and the existing water system information of the area. Thus, the proposed clustering method minimizes the source-demand distance by assigning demand to the source such that the distance to the source center is minimized. Euclidean norm minimization approach is used to minimize source-demand distance. The method also maximization of the homogeneity

within the cluster so that source-demand distance, topography, and demand variations are minimized. A K-means algorithm is applied to maximize intra-cluster homogeneity (Herrera et al., 2010). Centered on the above approaches, this section proposes two major steps for clustering WSS in an emerging area. These are: minimization of source-demand distance and maximization of intra-cluster homogeneity. The details of the proposed steps are shown in Figure 6.2 and discussed in subsections 6.3 and 6.4.

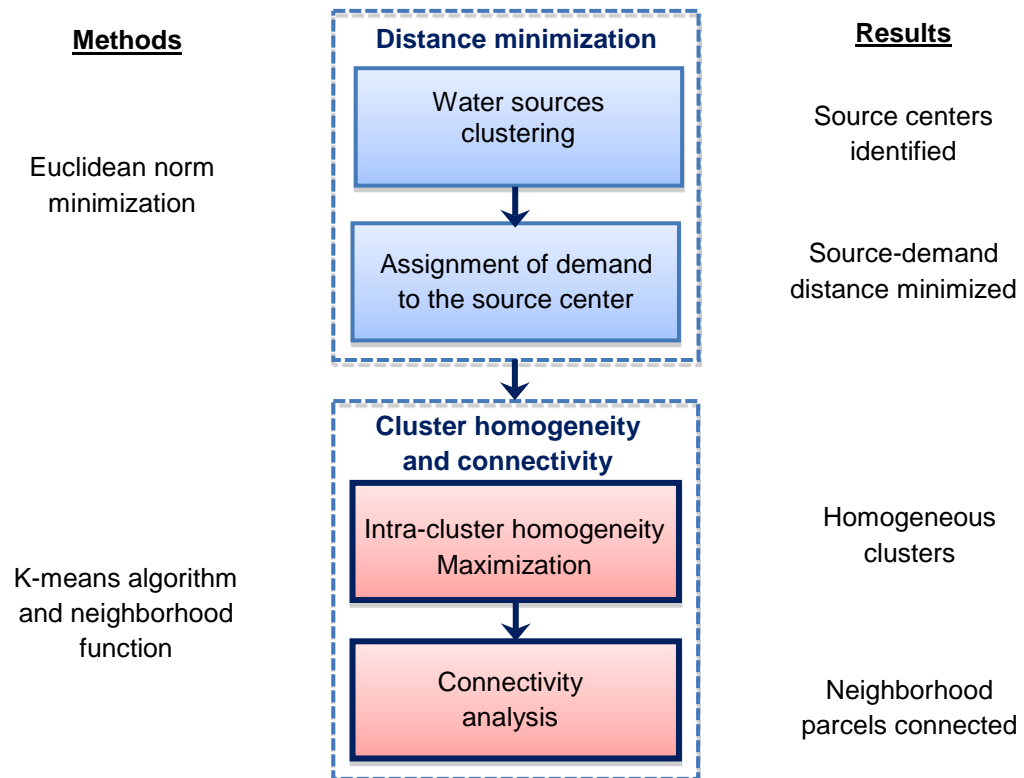

Figure 6.2 The proposed method for clustering WSS in emerging areas.

### 6.3 Minimization of Source-Demand Distance

This step involves two sub-steps such as a prior grouping of spatially distributed available water sources and assigning parcels such that the distance between source and grid parcel (demand cell) is minimized. Grid parcels are square cells characterized by attributes of spatial location (X and Y coordinates from the source center), elevation, and demand. The source-demand distance for each parcel depends on the specified source center locations. Euclidean norm minimization is proposed to optimize the source-demand distance for all clusters. The formulation is done as a demand assignment problem where each parcel is assigned to the nearest source. Then parcel membership will be determined from the minimization process.

The determination of the optimal number of source centers is not the focus of this chapter, the number of clusters for the area can be determined from the size of a cluster. According to Bieker et al. (2010), the size of a cluster has to be guided by the principle “as small as possible, as big as necessary” to achieve the ecological, economic, and social interest. BMBF (2006) compared different scales for areas which range from 10,000 up to more than 200,000 people and propose a recommended size ranging from 50,000 to 100,000 people as a suitable scale for an integrated semi-centralized system for fast growing urban areas. Bieker et al. (2010) also argued that this scale offers huge opportunity in recovering heat from wastewater streams as the transport distance is short. The size of a cluster could be used to pre-determine an initial number of clusters or

source groups, and could be changed during a connectivity analysis stage of the clustering process. Figure 6.3 shows a hypothetical example with 8 water sources and 121 demand parcels (each 0.01km<sup>2</sup>). It also illustrates the steps of assignment of demand parcels to the source center. The detailed methodology is discussed in the next subsections.

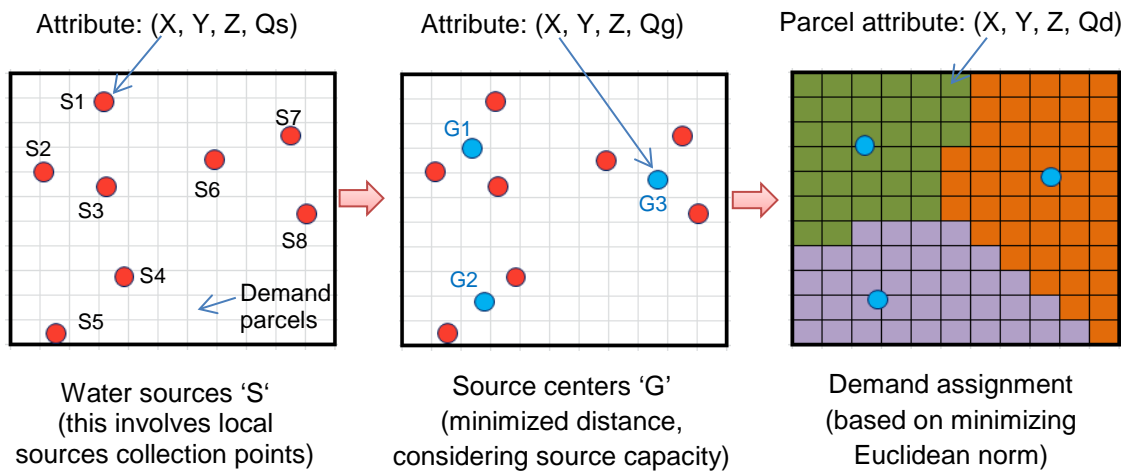

Figure 6.3 Assignment of parcels to the source center (X, and Y are location parameters, Z is elevation asl, Qd is parcel demand, Qs and Qg are capacity of local sources and group source capacity respectively)

### 6.3.1 Identification of Source Centers: Water Source Clustering

One of the major challenges in meeting future water and sanitation goals is servicing more people with less water. This requires us to consider a portfolio of options for water sources such as groundwater, surface water, storm water, and treated greywater. In addition, there is a need to critically look into the way we use and reuse water. Stormwater and wastewater need to be viewed as potential sources, rather than burdens.

Balancing the demands for water between the various sectors will need to be accompanied by the use of new and alternative resources (security through diversity). Thus, the first part of the proposed clustering method involves prior grouping of spatially distributed available water sources. This method involves grouping water sources and determining their group center such that the effort required for collection is minimized.

This stage evaluates the distance between available local sources, and groups them such that the distance between them is minimized. Distance comparison of one source with all other  $m$  sources will create  $m+1$  by  $m+1$  decision matrix. The number of clusters required could be used as an initial number for grouping the sources. Considering the hypothetical example with the eight available sources shown in Figure 6.3, a diagonal matrix for grouping them into three source groups is shown in Table 6.1. For this example only X and Y coordinates are used. Based on the minimum distance sources S1, S2, and S3 are grouped together and form source center G1; S4 and S5 form source center G2; and S6, S7 and S8 form source center G3.

Table 6.1 Source distance comparison matrix

		Capa. (LPS)	Location (m)		Sources distance (m)								Group
			X	Y	S1	S2	S3	S4	S5	S6	S7	S8	
			Sources	S1	100	3000	9000	0	2828	3000	7071	9220	
S2	90	1000		7000	2828	0	2236	5385	7000	8062	6000	8062	
S3	120	3000		6000	3000	2236	0	4000	6325	6325	4123	6000	
S4	50	3000		2000	7000	5099	4000	0	2828	8485	6403	7211	G2
S5	60	1000		0	9220	7071	6325	2828	0	11314	9899	10000	
S6	75	7000		7000	6083	8062	6325	6708	11314	0	2236	2000	G3
S7	95	9000		8000	6708	8062	6000	7211	10000	2000	0	2236	
S8	80	9000		6000	6708	8062	7000	7211	8485	2000	2236	0	

Once the groups of sources are identified, a simple source center calculation is carried out to determine the centroid of the sources within the same group. Taking a similar approach as in determining mass center, source center is calculated using the following equation

$$D_c = \frac{\sum_{s=1}^S D_i * Q_i}{\sum_{s=1}^S Q_i} \quad 6.1$$

where  $Q_i$  and  $D_i$  are the supply capacity of the source and the location (X and Y) from the reference point.

Assuming the capacity of each source, as shown in the second column of Table 6.2 for the above example, a sample calculation for source group G1 is shown below. Similarly, the source centers for G2 and G3 are calculated and tabulated in column 5 and 6 of Table 6.2.

$$Dx_c = \frac{3000 * 100 + 1000 * 90 + 3000 * 120}{100 + 90 + 120} = 2419m$$

$$Dy_c = \frac{9000 * 100 + 7000 * 90 + 6000 * 120}{100 + 90 + 120} = 7259m$$

Table 6.2 The centroid of the source groups

Sources	Capacity Q (LPS)	Location (m)		Source center (m)	
		X	Y	X <sub>c</sub>	Y <sub>c</sub>
S1	100	3000	9000	2419	7258
S2	90	1000	7000		
S3	120	3000	6000		
S4	50	3000	2000	1909	909
S5	60	1000	0		
S6	75	7000	7000	8400	7060
S7	95	9000	8000		
S8	80	9000	6000		

The result in Table 6.2 shows that the source center for: S1, S2 and S3 is located at (2419, 7259), for S4 and S5 is located at (1909, 909), and for S6, S7 and S8 is located at (8400, 7060). These source centers considered the supply capacity of each sources. Figure 6.3 also shows the spatial locations of these source centers.

### 6.3.2 Assignment of Demand Parcel to the Nearest Source

The issue of source-demand allocation originated from the availability of diverse local water sources and the need for clustering an existing central system into small and flexible clustered systems. The assignment of spatially distributed demand to the source center is crucial in minimizing the effort associated with the movement of water and wastewater. Thus, this section addresses the issue of



source allocation as a demand assignment problem where demand parcels will be assigned to the nearest source center.

The proposed method employs a minimization of the sum of Euclidean norms within the cluster. Minimizing the sum of Euclidean distance for shortest-path optimization has been proposed by many authors. The theories and algorithms for minimizing Euclidean distance can be applied to many optimization problems to yield higher complexity results for various applications. In this study, the sum of Euclidean norms is used to determine the membership of parcels based on the shortest distance to the source center. The same membership is given to the parcels that are assigned to the same source center. This increase the compactness (Dopp, 2011) and reduces the cost of pipe networks and the energy needed for pumping long distances. Compacted networks with closer proximity also increase resource efficiency by reducing leakage that would be higher in large centralized systems.

Given a set of parcels (representing the study area) with dimension vector  $P = \{P_1, P_2, \dots, P_n\}$ ,  $P \in \mathbb{R}^N$  Euclidean norm defines,  $\|P\| = (P * P)^{\frac{1}{2}}$ , if  $N = 1$  then  $\|P\| = |P|$ , the absolute value of  $P$ .  $\|P\|$  is the Euclidean norm of  $P$  that is used to measure the distance between points (Nachbar, 2009). For example, suppose  $P = (X, Y) \in \mathbb{R}^2$  and the source centers are defined by  $C = (X_1, Y_1) \in \mathbb{R}^2$ . Then the shortest distance from the source to the parcel is determined using Equation 6.2.

$$\min \|P\| = \sqrt{(X_1 - X)^2 + (Y_1 - Y)^2} \quad 6.2$$

Given the Euclidean norm of each parcel (from each source centers), the minimization is performed using Equation 6.3. Then each parcel will have membership (to the source center) based on the minimization of Euclidean norms. The membership defines grouping of similar parcels which are assigned to the same source center. The basic Euclidean norm minimization algorithm is shown in Figure 6.4.

$$\min d_{(P, P^c)} = \sum_{k=1}^c \|P\| = \sum_{k=1}^c \sqrt{\sum_{j=1}^n (P_j - P_j^c)^2} \quad 6.3$$

where  $d_{(P, P^c)}$  is the Euclidean norm from the source centers,  $P$  is an attribute which is described by parameters where the variation needs to be minimized (i.e location and elevation parameters).

The movement of water is based on an absolute distance which depends on the link (pipe) layout and pressure distribution; this requires hydraulic simulation of the whole network. However, to simplify the clustering process, in this study the minimization of the Euclidean norm is employed by using the relative distance based on the coordinate of demand parcels and supply centers. Once the parcels are assigned to the source center by the minimizing Euclidean norm principle, the membership values will be used in the maximization of cluster homogeneity (see subsection 6.4).

### Minimizing Euclidean norm algorithm

- i) For the given  $C$  source centers, the Euclidean norm of a parcel is determined with respect to their parameter  $P=\{P_1, P_2, \dots, P_n\}$ , yielding the distances  $d_{(p, p_c)}$ .
- ii) Given the set of Euclidean norms  $\{d_1, d_2, \dots, d_c\}$  for each parcel, the total cluster Euclidean norm is minimized by assigning a parcel to the nearest source center.
- iii) Steps i and ii are repeated until all parcels are assigned to the closest source centers (then a membership will be assigned to each parcel based on the source center to which they belong).

Figure 6.4 Basic minimizing Euclidean norm algorithm

## 6.4 Maximization Intra-cluster Homogeneity and Connectivity Analysis

Traditionally, the design of WSS has been performed for large spatial extent areas which involve a variety of topography, population distribution, land use, socio-economic, and associated demand. However, with the advent of decentralization, the study of the behavior of smaller areas has become a necessity so as to allow for uniformity within the clusters. Clustering of WSS so that the effort required for infrastructure development and operation is minimized through increased intra-cluster homogeneity is crucial.

In this section, clustering involving the maximization of intra-cluster homogeneity and connectivity analysis is proposed. Intra-cluster homogeneity is used to measure the similarity or dissimilarity between parcels of the same cluster. Maximization of intra-cluster homogeneity allows clustering the parcels so that parcel attributes within a cluster are closely related to one another (Herrera et al., 2010). Three major parameters are considered in the clustering process. These are membership (determined from Euclidean norm minimization), topography (elevation of the parcels), and spatio-temporal demand distribution (determined from the population distribution, land use, and socio-economic parameters). The clustering process involves the grouping of similar parcels. However, a measurement that can determine whether two parcels are similar or dissimilar is required. Thus, this section employs K-means optimization technique that maximizes intra-cluster homogeneity by minimizing the total cluster variance with respect to the mean value. In addition, this step involves a connectivity analysis to ensure the linkage of parcels within cluster. A simple neighborhood parcel definition is performed to determine the membership of each parcels and to check whether a parcel of one cluster is located in another cluster. The details of the proposed steps are discussed in the subsections.

#### **6.4.1 K-means for Clustering WSS**

“K-means clustering is a method of cluster analysis which aims to partition  $n$  observations into  $K$  clusters in which each observation belongs to the cluster with the nearest mean.” It is an evolutionary algorithm that minimizes the

proximity to the mean of the cluster (Singh et al., 2011). The name K-means comes from its method of operation in which it assigns observation on K clusters based on the observation's proximity to the mean of the cluster. The squared Euclidean norm is used as a measure of homogeneity. A K-means algorithm is a commonly employed method that converges to a local optimum value for clustering. It is very popular because it is computationally fast and memory efficient. In this section, a K-means algorithm is used to cluster the WSS in emerging areas based on the principle of minimizing the dissimilarity of the three parameters: source-demand distance, topography, and demand within the cluster. Unlike topography and demand, the distance parameter is dependent on the source centers; thus, the membership value (determined in subsection 6.3) of the distance is used to identify to which source center each parcel is assigned.

Given a set of parcels  $p$  representing the study  $\{X_1, X_2, \dots, X_p\}$ , where each parcel has  $n$ -dimension (i.e. topography, elevation), K-means clustering aims to partition the parcels ( $p$ ) into  $K$  clusters ( $K \leq p$ ) with assigned data-set  $S$   $\{S_1, S_2, \dots, S_k\}$ . For the given cluster assignment  $A$  that involve  $K$  groups, the total cluster variance is minimized through minimization of the sum of the squares of Euclidean norm for all clusters using Equation 6.5.

$$A = \arg \min_S \sum_{i=1}^K \sum_{X_j \in S_i} \|X_j - \mu_i\|^2 \quad 6.4$$

$$\mu_i = \frac{1}{N_i} \sum_{X_j \in S_i} X_j \quad 6.5$$

where  $A(i)$  cluster assignment,  $K$  is the number of clusters,  $N_i$  is the number data-set assigned to  $S_i$ ,  $\mu_j$  is mean of parcels in cluster  $S_i$  (Al-Saleh et al., 2009).

A K-means algorithm achieves optimal clustering assigning parcels so that the difference between parameters of the parcels and their centroids are as small as possible. It uses an iteration based evolutionary optimization which involves the assignment of parcels to the closest mean and calculating a new mean until the assignment no longer changes. Figure 6.5 shows the basic K-means algorithm used in clustering WSS.

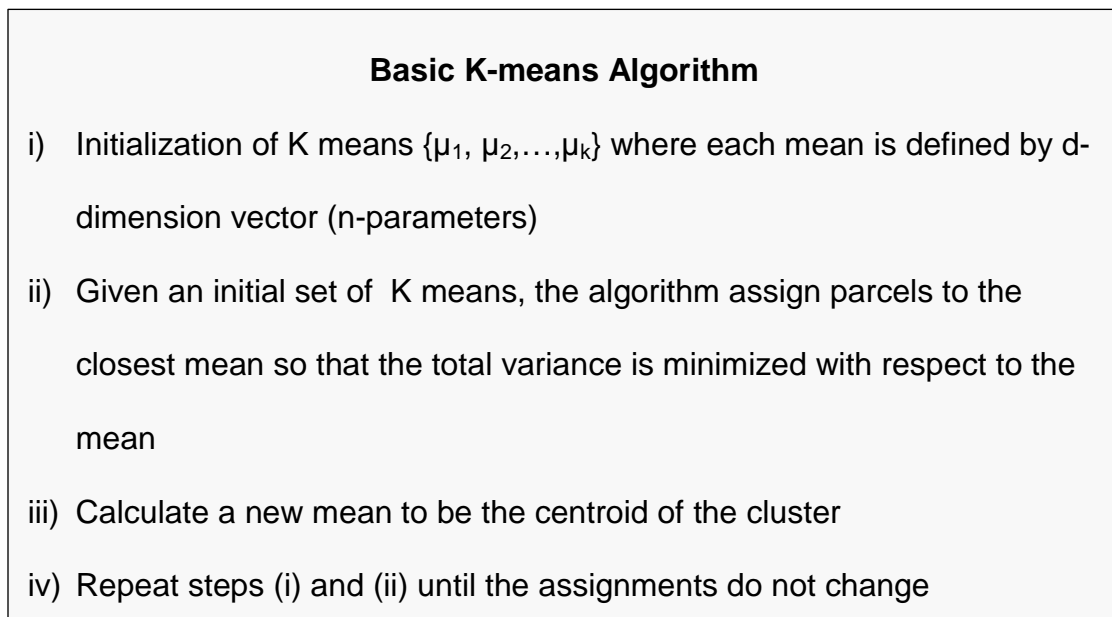

Figure 6.5 Basic K-means algorithm

For the hypothetical example discussed in the above subsections, the source-demand distance determined in subsection 6.3.1 and hypothetical

elevation and demand values for each parcel are used as an input. Figure 6.6 shows input parameters used and the resulting cluster using K-means algorithm.

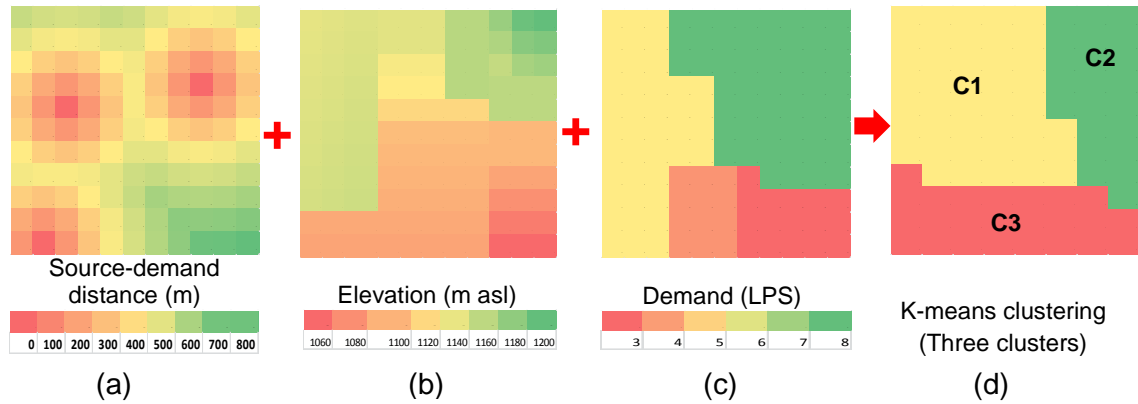

Figure 6.6 Showing clustering using K-means algorithm

Figure 6.6 (a) shows the parcels assigned to the nearest source center, and Figure 6.6 (b) and (c) are input topographic and demand parameters. Figure 6.6 (d) shows the resulting clusters using the proposed K-mean algorithm. These clusters involve demand parcels assigned to the nearest source and maximization of the homogeneity within the cluster is maximized by reducing the variation in demand, and topography parameters.

Though the K-means algorithm discussed above explored and maximized the similarity of clusters, it has its shortcomings. One of the limitations is that it does not consider the geospatial relative location of different neighboring parcels. However, the specific problem of clustering water systems requires the ability to handle not only the spatial extent, but also the geographic component with respect to neighboring parcels (i.e. the need to have the same membership

parcels in the same spatial location). To avoid the possibility of detaching parcels of the same cluster in different spatial locations, intra-cluster parcel connectivity is proposed. In addition, it is helpful to rerun the program using the same as well as different K values, to compare the results.

#### **6.4.2 Intra-cluster Parcels Connectivity**

Intra-cluster parcel connectivity, defined as the linkage of a parcel within a cluster, is used to check whether a parcel of one cluster is located in another cluster. Given the membership of parcel  $p$  defined as  $P_{(m,n)}$  and neighborhood parcels as  $P_{(n\pm 1, m\pm 1)}$ , if parcel  $P_{(m,n)}$  of one cluster neighbors two or more parcels of another cluster, and only one or less neighbors from its own cluster, the evaluation of the minimum Euclidean norm of the parcel  $P_{(m,n)}$  is performed with respect to the neighboring cluster centroid and is re-assigned to the closest one. In addition, the periphery parcels which don't have many neighbors are merged to the nearest cluster group in case they belong to other cluster. This connectivity analysis alone does not guarantee the existence of cluster members in another spatial location. One can use the smallest recommended size of cluster and/or the smallest demand that a cluster should supply to decide on merging isolated parcels to the neighboring cluster. An isolated parcel group will be kept as an independent cluster if the demand it supplies is greater than the required minimum size/ demand within the cluster. However, a parcel group that does not satisfy the mentioned condition will be merged to the neighbor cluster. The



decision of which cluster to combine will be made by evaluating the minimum Euclidean norm value with respect to the centroid of neighboring clusters.

## **6.5 Conclusions: Optimization for Clustering WDS**

This chapter addressed the objective of developing a new optimization model that supports the development of clustered (decentralized) distribution systems.

Currently no method exists which guides planners on how to cluster WDS. To address this need, a methodology has been developed in this chapter that allows for better clustering of WDS for emerging areas into small and adaptable systems. The developed clustering methodology is based on two major principles: the minimization of the distance from source to consumer by assigning demand to the closest source center, and the maximization of the homogeneity within the cluster.

Euclidean norm minimization has been used to optimize the source-demand distance for all parcels to minimize the transportation distance and corresponding infrastructure requirements. Intra-cluster homogeneity was used to measure the similarity or dissimilarity between parcels of the same cluster. Maximization of intra-cluster homogeneity allows clustering the parcels so that parcel attributes within a cluster are closely related to one another (Herrera et al., 2010). Three major parameters are considered in the clustering process. These

are membership (determined from Euclidean norm minimization), topography (elevation of the parcels), and spatio-temporal demand distribution (determined from the population distribution, land use, and socio-economic parameters). This chapter applied K-means optimization technique to maximize intra-cluster homogeneity to reduce the costs associated with water system investment and operation (energy and leakage) and improve resource efficiency (recycling). The efficacy of the developed clustering method will be demonstrated in a real case study of Arua, Uganda in chapter 7.

## 7 Flexibility of Clustered WDS: Case Study, Arua, Uganda

### 7.1 Introduction

This chapter addresses the specific research objective of verifying whether a decentralized clustered system provides a higher flexibility compared to a conventional centralized WDS.

This chapter first hypothesizes that decentralized systems provide greater flexibility compared to centralized systems and verifies this hypothesis using a case study analysis. The verification of this hypothesis involves two major steps:

- i) This chapter applies the clustering method developed in Chapter 6 to a real case study in Arua, Uganda to establish clusters in the emerging area of the town based on the objectives of minimizing the source-demand distance, and maximizing intra-cluster homogeneity.
- ii) Using the framework for flexibility analysis developed in Chapter 3, this chapter develops clustered WDS for Arua, Uganda and analyzes whether decentralized clustered WDS provides more flexibility compared to conventional centralized WDS (see Figure 7.1).

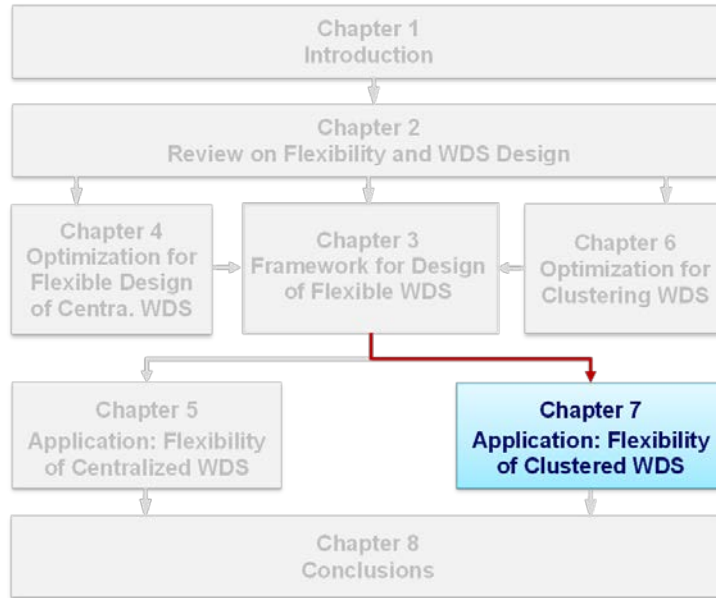

Figure 7.1 The interconnection of Chapter 7 with other chapters

## 7.2 General Description of the Area

Arua town is located in the Northern Region of Uganda and lies between latitude 2030' N and 3050' N and longitude 30030' E and 31030' E (see Figure 7.2). The Arua municipality is one of the fastest growing municipalities in the country. The municipality is made up of 2 divisions (sub-counties), namely Arua Hill Division and Oli River Division, and covers an area of 1014 ha. It is located about 520 km away from Kampala, the capital city of Uganda. According to the statistical abstracts of the Uganda Bureau of Statistics (UBOS, 2011), the population of the Arua municipality was 59,400 in 2011, with the population around the periphery of the municipality reported as 49,893. With an annual growth rate of 3.4%, the total population in 2032 is estimated to be 220,887 (see Figure 7.3).

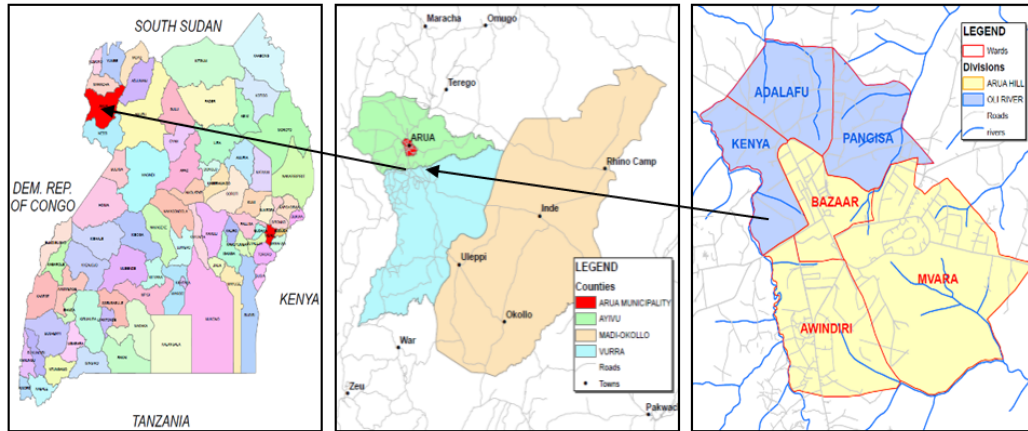

Figure 7.2 Geographic location of Arua town

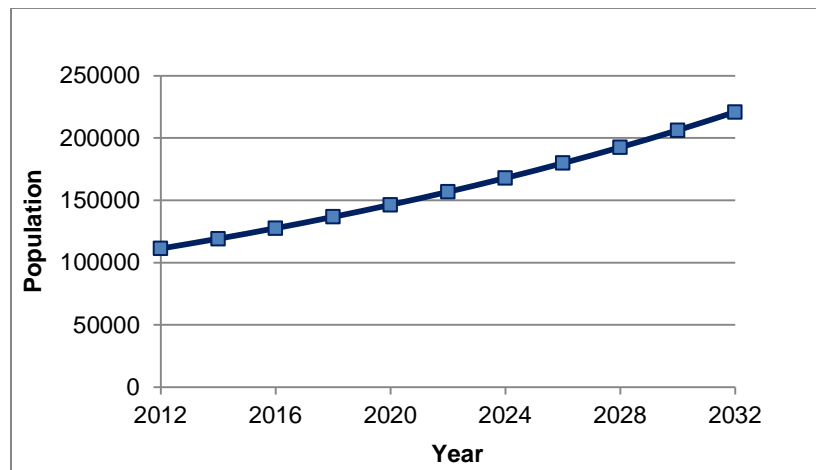

Figure 7.3 Predicted future population in Arua

The prediction of the future population for 2032 suggests that Arua will expand to the new development central business district (South and Southwest), which follows the road layout in the North and Northwest directions. The extent of the spatial growth of Arua in 2032 is shown in Figure 7.4.

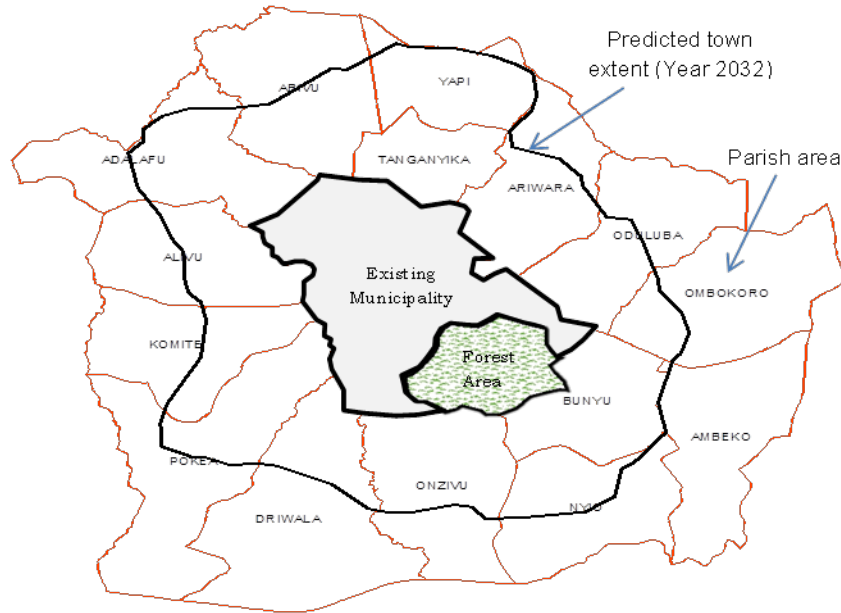

Figure 7.4 Predicted spatial extent of Arua in year 2032

The town of Arua is experiencing a critical shortage of water as it depends on only a small river (Enyau River) for its supplies (COWATER, 2005). The current water supply of 2000m<sup>3</sup>/d is not sufficient to meet the town's demand. With a population growth and increasing wealth it is predicted that the water demand will likewise rise to 17,217 m<sup>3</sup>/d in the year 2032, which would increase the water shortage. This predicted future demand takes into consideration the different population density and socio-economic status of each of the parish areas. Table 7.1 shows socio-economic status and associated demand categories for the parish areas. Figure 7.5 shows the predicted future water demand for the town.

Table 7.1 Socio-economic status and demand categories for parish areas

Parish's Areas	% Population			
	High (110LPCD)	Medium (80LPCD)	Medium-Low (60LPCD)	Low (40LPCD)
Alivu & Adalafu	5%	30%	40%	25%
Arivu, Yapi & Tanganyika	5%	35%	35%	25%
Ariwara	5%	35%	45%	15%
Oduluba, Ombokora & Bunyu	10%	50%	30%	10%
Bunyu, Nyio & Onzivu	10%	50%	30%	10%
Forest Area	20%	60%	20%	0%
Onzivu, Driwala	10%	50%	30%	10%
Pokea, Komite & Alivu	5%	35%	45%	15%
Municipal	5%	50%	25%	20%

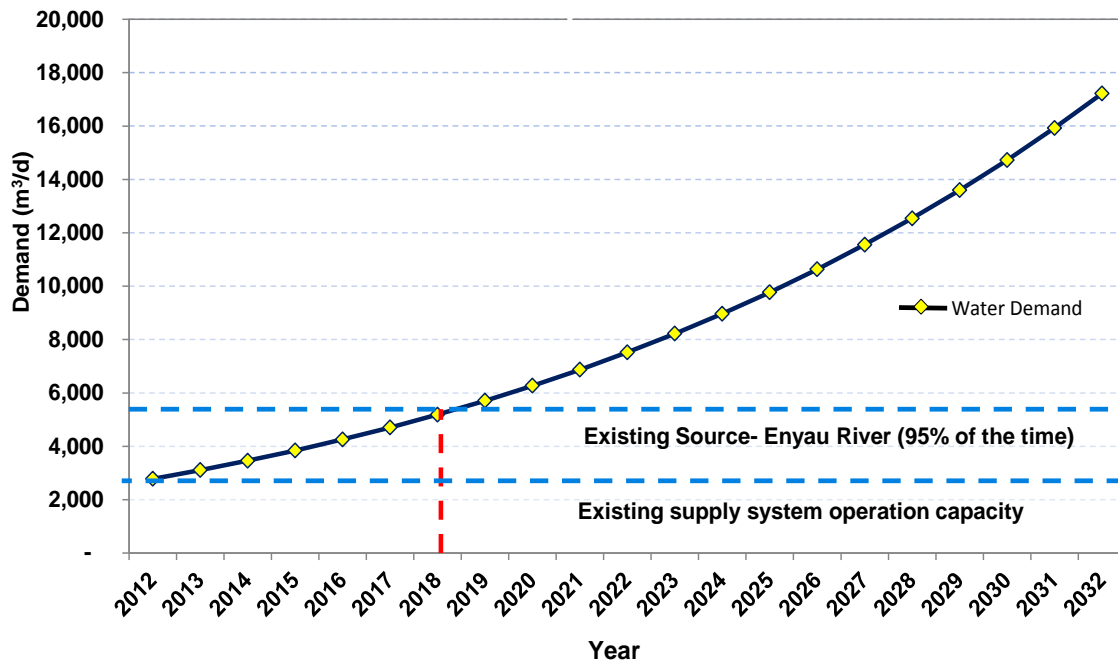

Figure 7.5 Future water demand in Arua

The current approach to water management in Arua is based on a conventional centralized approach where water is collected upstream, used, and discharged downstream and does not encourage the use of local sources such as groundwater, stormwater harvesting, or wastewater reuse and recycling. It has become obvious that the current practices of urban water management are not sustainable to meet the challenges in Arua. However, the rapid urban growth in emerging areas coupled with the fact that those emerging areas do not have mature infrastructure and urban planning for the area has not yet occurred means that there are real opportunities to implement clustered urban water system management in Arua. This study shows that a clustered approach to urban water management will help to set emerging towns on a sustainable path by providing the potential to satisfy the water needs of communities at the lowest cost while minimizing adverse environmental and social impacts. Thus it is with this respect that the clustering technique is applied to Arua town.

### **7.3 Application of the Proposed Clustering Method**

One of the major initiatives of the Arua municipality is to de-gazette the forest area (called Barifa) in a 5-year time period and incorporate it into the central business district. The proposed municipality plan also includes developing residential community services such as social centers (e.g. churches and mosques, etc.) and a major market center. Since the forest area has a predefined boundary, the clustering processes in this study isolate these areas and treat them as pre-clustered unit. Additionally, prior to the clustering process,



a decoupling of the existing central WSS from the emerging areas is performed by identifying the municipality boundary (see Figure 7.6). Then the proposed WSS clustering technique which minimizes the source-demand distance and maximizes intra-cluster homogeneity is applied. The results are discussed below.

### **7.3.1 Source-Demand Distance Minimization**

The first part of the proposed clustering method involves prior grouping of spatially distributed available water sources. This involves 10 groundwater sources and 4 potential surface water abstraction locations (see Figure 7.6). Once the capacity and locations of available sources are identified, the aim is to merge the available sources into groups such that the distance between grouped sources is minimized. In this case study, the area is discretized into small parcels of size, 150m by 150m. The available source clustering is limited to the emerging areas (excluding Barifa forest). The available sources of the emerging area are grouped into seven groups. For this study, the number of source groups is used as an input parameter. The decision to propose a number of groups might depend on the size of the area, the size of clusters required, the numbers of sources available, etc. Different researchers have highlighted the need for case-to-case analysis to determine the population number that should be supplied by a single cluster to determine the smaller cluster size (BMBF, 2006; Bieker et al., 2010). However, the determination of the number of groups required is not the focus of this study. Thus the minimum size of cluster with population 25,000

considered in decentralizing the emerging area by Webster et al. (2012) is used to determine the input number of source centers for grouping.

The evaluation of the distance between sources is done using Equation 6.2 (Chapter 6). The comparison matrix for grouping is developed and shown in Appendix 1. The output of source-group identification process is shown in Figure 7.6 (a) and (b). Once the groups are identified the X, Y coordinate and supply capacity  $Q_s$  are used to calculate source-centers. Table 7.2 summarized the source and source-center information's.

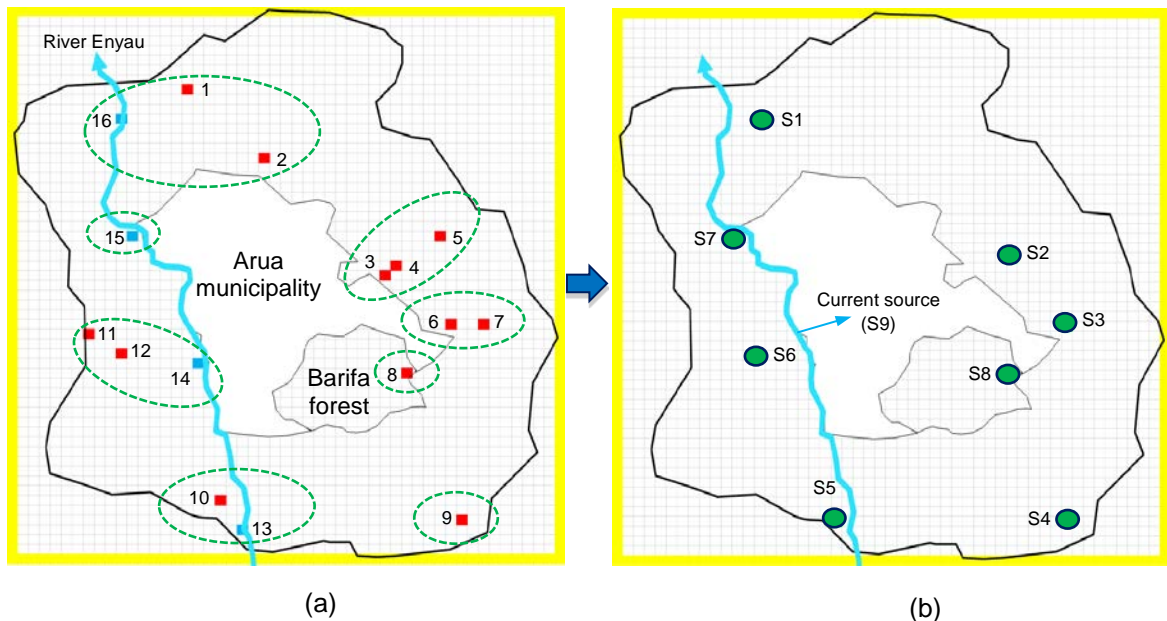

Figure 7.6 (a) Available water sources and their groups; (b) Water-source centers (based on minimized Euclidean distance)

Table 7.2 Source groups and location of source centers

Source Group	Source no.	Water source-centers	
		X (m)	Y (m)
1	1	1992	6772
	2		
	16		
2	3	5461	4650
	4		
	5		
3	6	6181	3600
	7		
4	9	6150	600
5	10	3110	510
	13		
6	11	2062	3108
	12		
	14		
7	15	1650	4950
Forest (8)	8	5400	2850
Municipality (9)		2400	3150

Once the source center is identified, the discretized square parcels (150m by 150m) are assigned to the source centers. Each parcel has a location, topography, and demand attribute. This stage uses the location attribute (X, Y) coordinate of parcels and the centroid of available sources as an input to minimize the source-demand location for each parcel. In this case study, the distance minimization is limited to the emerging areas, in which emerging areas in Arua include the Barifa forest. This case study treats the forest areas as an independent unit cluster where the boundary and inbounded source is pre-identified prior to the clustering process. Thus, water source number 8 is pre-assigned to cluster 8 (planned development). In addition to the center municipality boundary, this study treats the forest areas as independent unit clusters where the boundary is pre-identified prior to the clustering process. Equation 6.2 is applied to each parcel of the emerging areas (except Barifa forest

and the Arua municipality) to determine the Euclidean norm from the 7 source centers in the emerging area. Given the Euclidean norm of each parcel (from the 7 source centers), the distance minimization is performed using Equation 6.3. Then, each parcel is assigned with a membership value. Figure 7.7 (a) and (b) show the parcels assigned to the nearest source and the membership respectively. The membership defines groupings of similar parcels which are apportioned to the same source center.

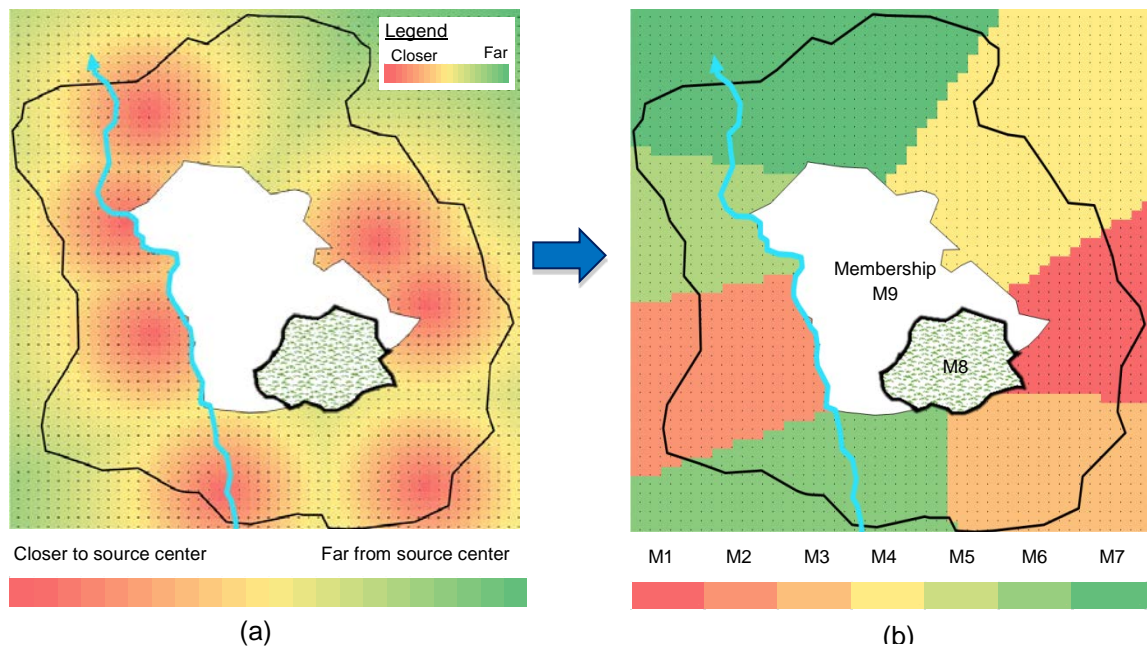

Figure 7.7 (a) Parcel assignment (Minimized Euclidean norm). (b) Parcel membership-M based on source-demand distance

The above clustering is purely based on distance and does not include demand and topographic parameters. However, demand and topography are other parameters which affect the transport of water and wastewater in the area. The next stage incorporates demand and topography in addition to membership value to cluster the study area.

### 7.3.2 Maximizing Homogeneity: K-means Clustering

The proposed homogeneity maximization is applied to determine the final cluster boundary for the study area. Finding an optimal boundary which maximizes homogeneity is performed using the K-means algorithm. The distance-based membership value (determined in subsection 6.3), topographic, and demand information are used as input parameters. The study area topography ranges from 1160m to 1240m asl, and the determination of demand is performed using the population, socio-economic status, and land use information. The input elevation and demand information are plotted for the case study area and shown in Figure 7.8 (a) and (b). The different colors show different elevation/demand values.

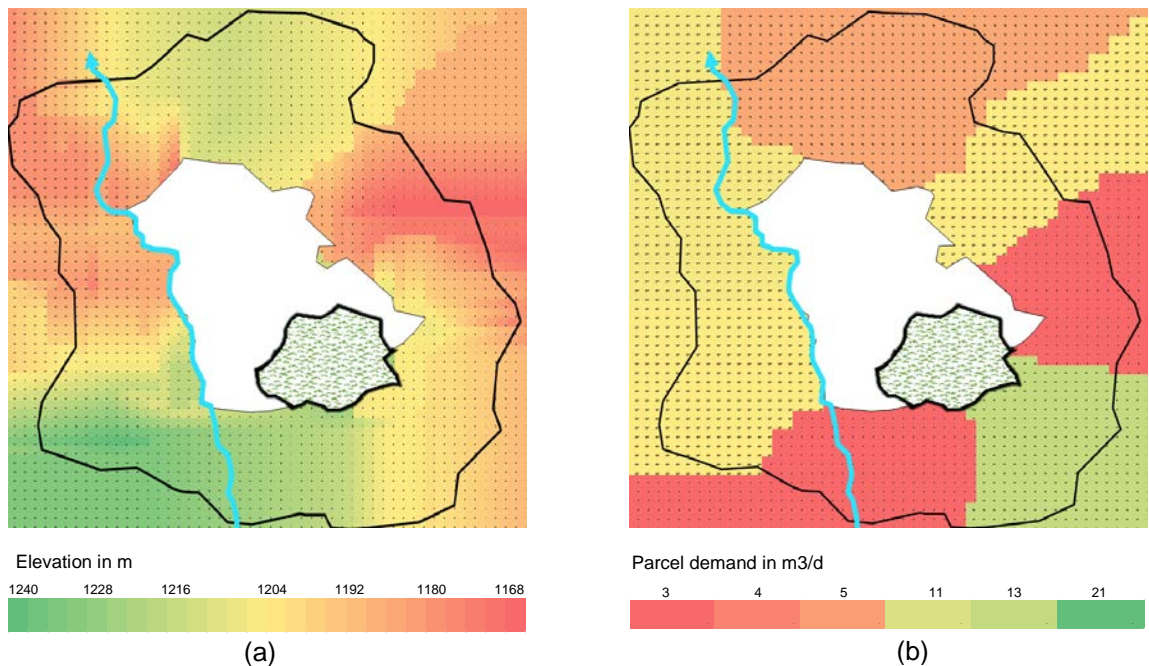

Figure 7.8 (a) elevation in m (asl). (b) parcel demand in m3/d



Given the input parameters, a K-means algorithm is applied to maximize intra-cluster homogeneity. In this study, the area was required to be partitioned into 7 clusters. The method begins by selecting an initial mean (for each cluster), and assigning the parcels to each mean center. Then the means for each cluster are modified until there is no change in assignment of parcels. In this study, multiple runs of the K-means simulation are performed to avoid the problem associated with initialization, and the algorithm showed similar clusters. The final output of the clusters is shown in Figure 7.9 (a). The different color code represents different memberships of the parcels.

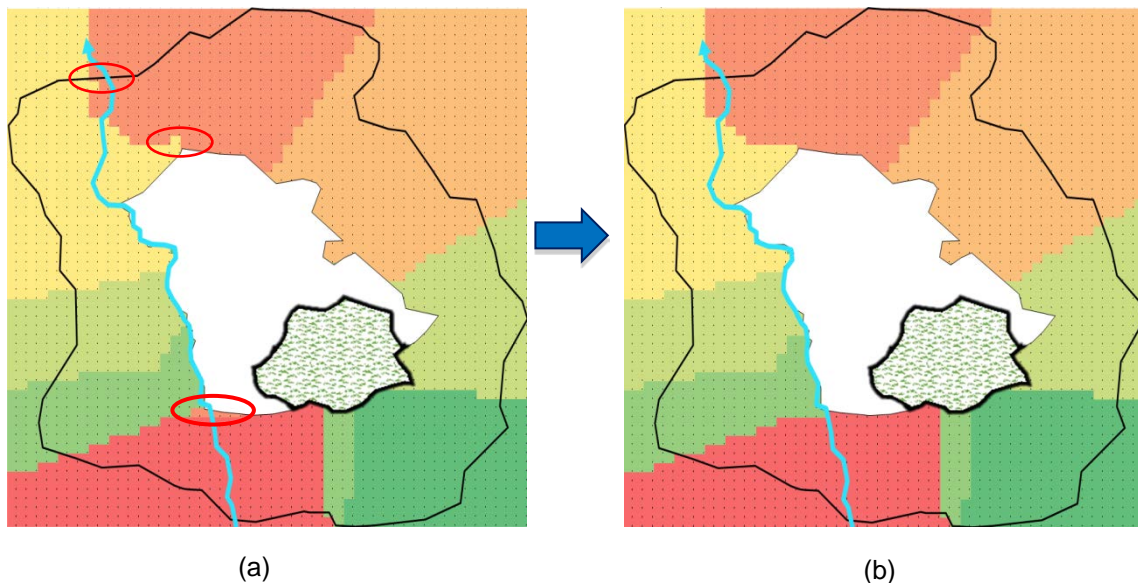

Figure 7.9 (a) K-means clusters (b) Cluster after merging isolated parcels

However there are some limitations of the K-means algorithms. One problem is that clusters for the same members could be located in different spatial locations, as shown in Figure 7.9 (b). To incorporate the spatial component of cluster location, the neighborhood identification proposed in

subsection 6.4.2 is applied. The neighborhood identification involves refining the boundary and merging parcels of one cluster which are located in a different cluster.

First, simple neighborhood parcel connectivity is done by considering the membership of each parcel. If a parcel is surrounded by other three or more parcels of a different cluster and has one only one or fewer neighbors from its own cluster, it is re-signed to the closest one. In this case study, parcels circled red in Figure 7.9 (a) are merged to their neighbors.

Secondly, if there is a parcel group which is located in another cluster, the size is used to decide whether to keep the group as a new independent cluster or to merge it with the nearest cluster. A group merging is performed if a cluster/group is too small. In this study, groups with a size less than 20% of the maximum cluster size are distributed to the neighboring cluster to avoid large variation in cluster size. However, a recommended size of cluster and/or the smallest demand that a cluster should supply could be used for deciding whether to merge isolated parcels. Figure 7.10 (a) shows the final cluster boundary after isolated neighboring parcels are re-distributed, and the final cluster boundary for the case study area is shown in Figure 7.10 (b).

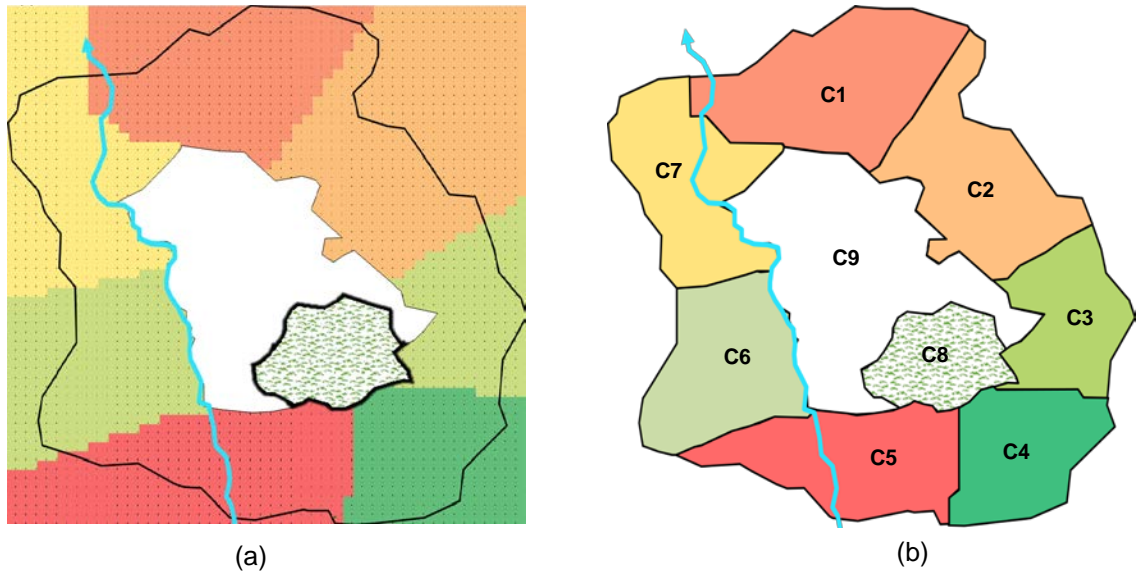

Figure 7.10 (a) Cluster after re-distributing small groups (b) Final cluster

The result in Figure 7.10 (b) shows final cluster boundary for the case study area. The developed clustering method offers an adequate solution to the decentralization paradigm through clusters that allow for improving the movement of water and wastewater in the area. It divides emerging urban area into clusters to allow for the provision of flexible, modular decentralized WDS. In the next subsection, the cluster boundaries are used to develop decentralized WDS for Arua, Uganda and a detailed evaluation of clusters with respect to flexibility is analyzed to verify whether clustered WDS offer greater flexibility than conventional centralized WDS.

#### 7.4 Flexibility of Clustered WDS: Case Study Arua, Uganda

Recently, researchers have questioned whether clustered/decentralized WDS provide greater flexibility when compared with conventional centralized



WDS (Webster et al., 2012; Bieker et al., 2010; PSGS, 2010; Valerie, 2008). Clustered WDS can be implemented in an incremental fashion that traces the urban growth trajectory more closely. It is assumed that decentralized WDS provide a better flexibility against the uncertainties of spatial growth than conventional centralized systems. This assumption is supported by general considerations from Bieker et al. (2010) and Fricke and Schulz (2005). However, the hypothesis that clustered (decentralized) systems provide greater flexibility than centralized systems has to be verified. Thus, this subsection analyzes a practical application to determine whether decentralized clustered WDS provide more flexibility than conventional centralized WDS using the framework and tool for flexibility analysis developed in Chapter 3 and 4. Arua, Uganda is used for this case study.

One of the major uncertainties involved in the future of the water system is the extent of the spatial expansion of the town due to unplanned growth. In addition, the water demand in the area will vary depending on variations in population growth and the socio economic variations. It is therefore very important to take these future variations into consideration (Bernanke, 1983). In order to compare the clustered and centralized WDS in Arua, this study considered the predicted temporal and spatial growth of the town the associated uncertainties. According to (Webster et al., 2012) the prediction of future growth shows that Arua will expand to the new development central business district (South and Southwest) directions in the coming 10 years, and will follow the road

layout in the North and Northwest direction in 15 years and to the East low-land areas in 20 years' time. Although this prediction is based on some plans of the city council and current growth trends of the town, different growth paths could be followed due to shifts in economic and infrastructure developments. The predicted growth mentioned above is one of the many growth scenarios that may range from a no growth option (lower bound) to a critical (maximum) growth option (Upper bound). The range between the upper and lower bound of spatial growth reflect the uncertainties of the growth path of the town. Accordingly eleven basic scenarios were considered that represent staged spatial growth of the town (See Figure 7.11 and Table 7.3 for the scenarios). Figure 7.11 shows scenario tree that describes the future possible demand in tractable manner.

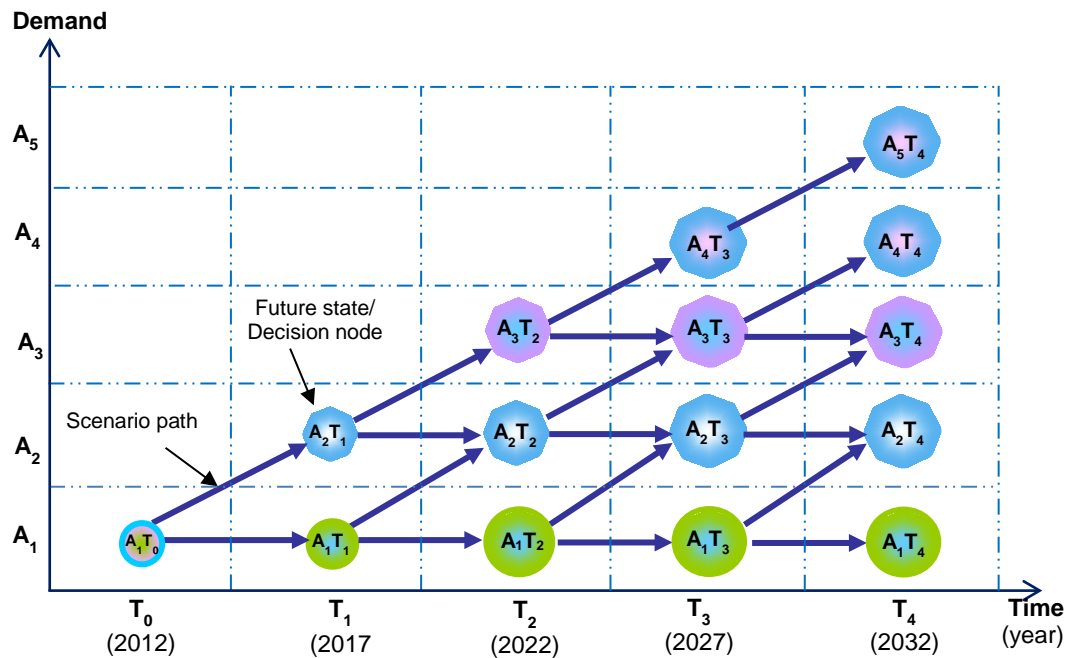

Figure 7.11 Scenario tree representing the future demand

Table 7.3 Lists of scenario considered (for Arua town)

Scenario No.	Scenario
1	$A_1T_0 - A_1T_1 - A_1T_2 - A_1T_3 - A_1T_4$
2	$A_1T_0 - A_1T_1 - A_1T_2 - A_1T_3 - A_2T_4$
3	$A_1T_0 - A_1T_1 - A_1T_2 - A_2T_3 - A_2T_4$
4	$A_1T_0 - A_1T_1 - A_2T_2 - A_2T_3 - A_2T_4$
5	$A_1T_0 - A_2T_1 - A_2T_2 - A_2T_3 - A_2T_4$
6	$A_1T_0 - A_2T_1 - A_2T_2 - A_2T_3 - A_3T_4$
7	$A_1T_0 - A_2T_1 - A_2T_2 - A_3T_3 - A_3T_4$
8	$A_1T_0 - A_2T_1 - A_3T_2 - A_3T_3 - A_3T_4$
9	$A_1T_0 - A_2T_1 - A_3T_2 - A_3T_3 - A_4T_4$
10	$A_1T_0 - A_2T_1 - A_3T_2 - A_4T_3 - A_4T_4$
11	$A_1T_0 - A_2T_1 - A_3T_2 - A_4T_3 - A_5T_4$

The corresponding water demand for each of the staged growths is shown in Figure 7.12 (for cluster names refer to the previous subsection 7.3). In this case, four stages of growth (5th, 10th, 15th and 20th year) have been considered over a design horizon of 20-years.

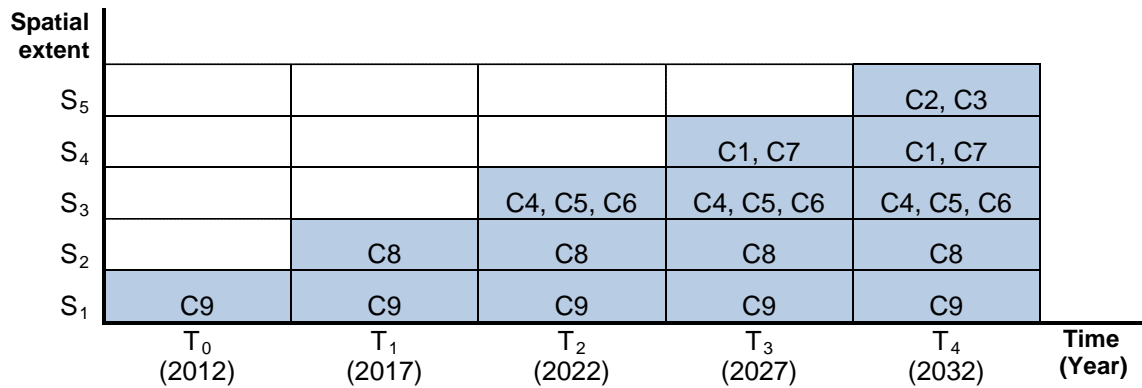

Figure 7.12 Staged spatial growth for the town

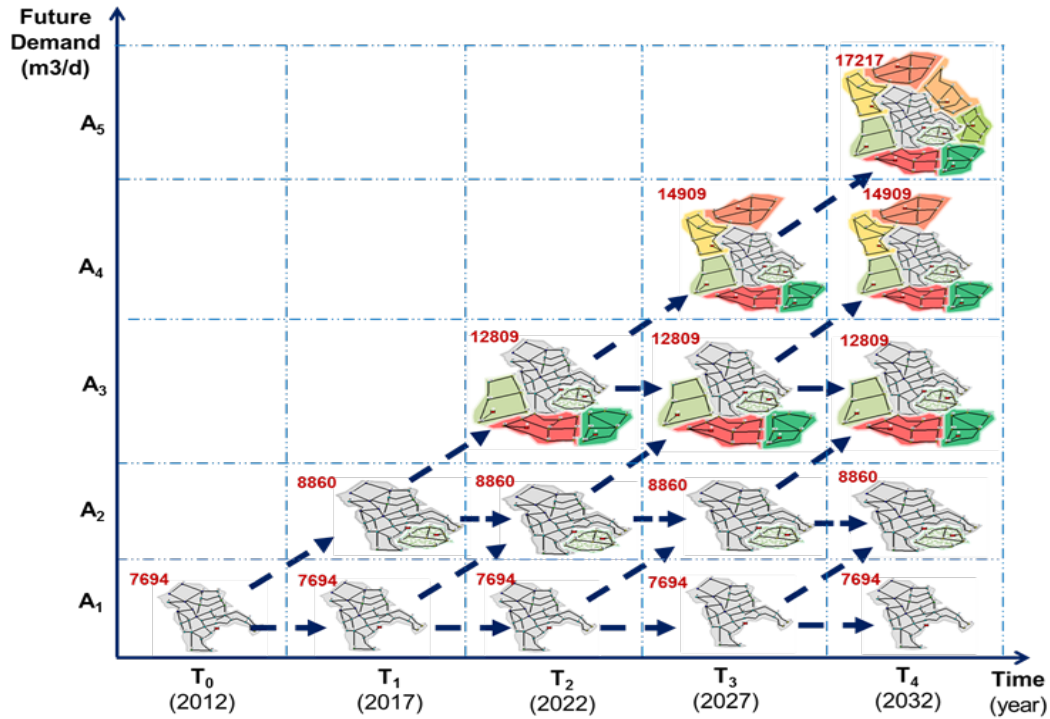

Figure 7.13 Water demand scenarios (spatial and temporal- A in m<sup>3</sup>/d)

The water demand values represent cumulative of all nodal demands in the area. The eleven scenarios listed in Table 7.3 represent the different possible combination of the water demand A and time T shown in Figure 7.13. The scenarios are used as input for the design of centralized and clustered WDS. In order to analyze the flexibility of the two systems, the centralized WDS is designed based on traditional approach where the system growth in centralized fashion, whereas the flexibility framework developed in Chapter 3 applied to develop clustered/decentralized WDS for Arua town. Then the flexibility of the two systems is analyzed with respect to the future change scenarios.

#### 7.4.1 Centralized and Clustered WDS

The WDS design process considered the centralized as well as the clustered system to accommodate the predicted future spatial and temporal demand growth of the town for 20 years. The values for pipe cost and laying costs are used from Mbale, Uganda. The total cost is the sum of pipe material and laying cost, calculated using Equation 6.6.

$$C_{WDS} = C_{pipe} + C_{labor} \quad 7.1$$

Thirteen different commercially available diameters are used. The pipes' diameters range from a minimum of 50.8mm to a maximum of 609.6mm. The pipe diameters and their associated material and laying costs shown in Table 5.3 are used for designing (Prasad et al., 2004; NWSC, 2012). GA is applied to determine an optimal WDS for the range of uncertainties considered.

Centralized WDS for the area is designed using a conventional design approach where the existing central WDS is expanded to the emerging area of the town. The WDS development follows the predicted spatial growth of the city. Figure 7.14 shows the designed optimal WDS extent at different stages. The optimized WDS costs (in NPV terms) for each possible scenario are summarized in Table 7.4. The total NPV includes the cost of reservoir for the centralized system. A detailed calculation of reservoir costs is shown in Appendix 2.

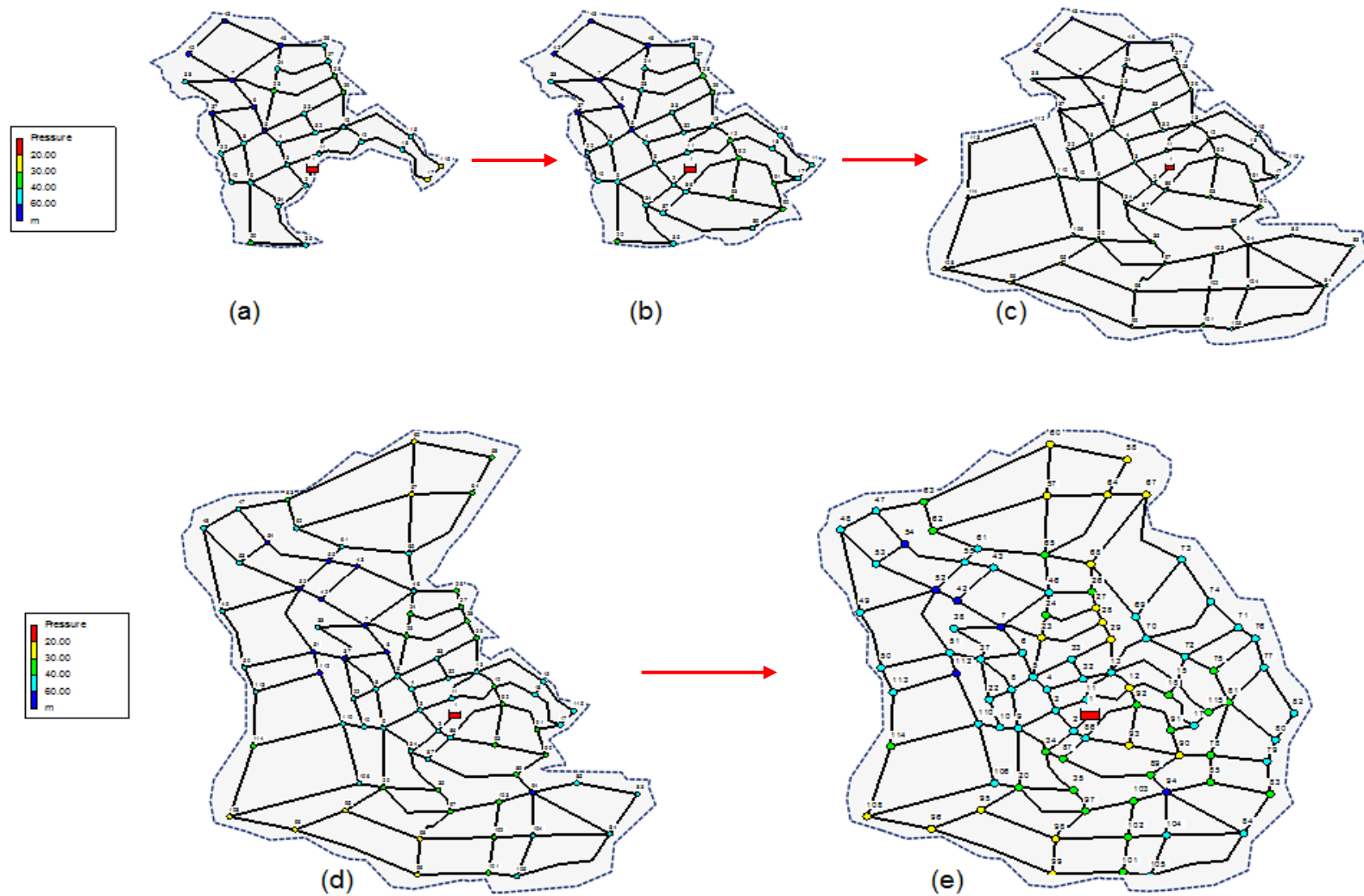

Figure 7.14 Staged development of centralized WDS for Arua town (scenario A<sub>1</sub>T<sub>0</sub>- A<sub>2</sub>T<sub>1</sub>- A<sub>3</sub>T<sub>2</sub>- A<sub>4</sub>T<sub>3</sub>-A<sub>5</sub>T<sub>4</sub>):(a) Year T<sub>0</sub> (b) Year T<sub>1</sub>; (C) Year T<sub>2</sub>; (d) Year T<sub>3</sub> (e) Year T<sub>4</sub>)

Table 7.4 Cost of centralized WDS

Scenario No.	Scenario	Clustered WDS (US\$)
1	A <sub>1</sub> T <sub>0</sub> - A <sub>1</sub> T <sub>1</sub> - A <sub>1</sub> T <sub>2</sub> - A <sub>1</sub> T <sub>3</sub> - A <sub>1</sub> T <sub>4</sub>	964,208
2	A <sub>1</sub> T <sub>0</sub> - A <sub>1</sub> T <sub>1</sub> - A <sub>1</sub> T <sub>2</sub> - A <sub>1</sub> T <sub>3</sub> - A <sub>2</sub> T <sub>4</sub>	1,104,607
3	A <sub>1</sub> T <sub>0</sub> - A <sub>1</sub> T <sub>1</sub> - A <sub>1</sub> T <sub>2</sub> - A <sub>2</sub> T <sub>3</sub> - A <sub>2</sub> T <sub>4</sub>	1,126,968
4	A <sub>1</sub> T <sub>0</sub> - A <sub>1</sub> T <sub>1</sub> - A <sub>2</sub> T <sub>2</sub> - A <sub>2</sub> T <sub>3</sub> - A <sub>2</sub> T <sub>4</sub>	1,152,892
5	A <sub>1</sub> T <sub>0</sub> - A <sub>2</sub> T <sub>1</sub> - A <sub>2</sub> T <sub>2</sub> - A <sub>2</sub> T <sub>3</sub> - A <sub>2</sub> T <sub>4</sub>	1,182,944
6	A <sub>1</sub> T <sub>0</sub> - A <sub>2</sub> T <sub>1</sub> - A <sub>2</sub> T <sub>2</sub> - A <sub>2</sub> T <sub>3</sub> -A <sub>3</sub> T <sub>4</sub>	1,440,495
7	A <sub>1</sub> T <sub>0</sub> - A <sub>2</sub> T <sub>1</sub> - A <sub>2</sub> T <sub>2</sub> - A <sub>3</sub> T <sub>3</sub> -A <sub>3</sub> T <sub>4</sub>	1,481,516
8	A <sub>1</sub> T <sub>0</sub> - A <sub>2</sub> T <sub>1</sub> - A <sub>3</sub> T <sub>2</sub> - A <sub>3</sub> T <sub>3</sub> -A <sub>3</sub> T <sub>4</sub>	1,529,071
9	A <sub>1</sub> T <sub>0</sub> - A <sub>2</sub> T <sub>1</sub> - A <sub>3</sub> T <sub>2</sub> - A <sub>3</sub> T <sub>3</sub> -A <sub>4</sub> T <sub>4</sub>	1,789,360
10	A <sub>1</sub> T <sub>0</sub> - A <sub>2</sub> T <sub>1</sub> - A <sub>3</sub> T <sub>2</sub> - A <sub>4</sub> T <sub>3</sub> -A <sub>4</sub> T <sub>4</sub>	1,830,817
11	A <sub>1</sub> T <sub>0</sub> - A <sub>2</sub> T <sub>1</sub> - A <sub>3</sub> T <sub>2</sub> - A <sub>4</sub> T <sub>3</sub> -A <sub>5</sub> T <sub>4</sub>	1,989,697

Clustered WDS for Arua town is also designed based on the new approach such that it involves small and decentralized autonomous WDS for each cluster. The WDS for a clustered system has the same layout as the centralized WDS that is used for clustered systems. A staged design of clusters following the predicted growth pattern is performed using the GA optimization technique. For example, the stage development for scenario A<sub>1</sub>T<sub>0</sub>- A<sub>2</sub>T<sub>1</sub>- A<sub>3</sub>T<sub>2</sub>- A<sub>4</sub>T<sub>3</sub>-A<sub>5</sub>T<sub>4</sub> involves expansion to cluster C8 in year 2017; to clusters C4, C5 & C6 in year 2022; to clusters C1 & C7 in year 2027; and to clusters C2 & C3 in year 2032. The designed optimal clustered system for this scenario is shown in Figure 7.15. The diagrams from Figure 7.15 (a) to (d) show the design stages of a clustered WDS for the town under scenario A<sub>1</sub>T<sub>0</sub>- A<sub>2</sub>T<sub>1</sub>- A<sub>3</sub>T<sub>2</sub>- A<sub>4</sub>T<sub>3</sub>-A<sub>5</sub>T<sub>4</sub>. The optimized WDS costs (in NPV terms) for each possible scenario are summarized in Table 7.4. The total NPV includes the cost of reservoirs for the decentralized system and the detailed calculation is shown in Appendix 2.

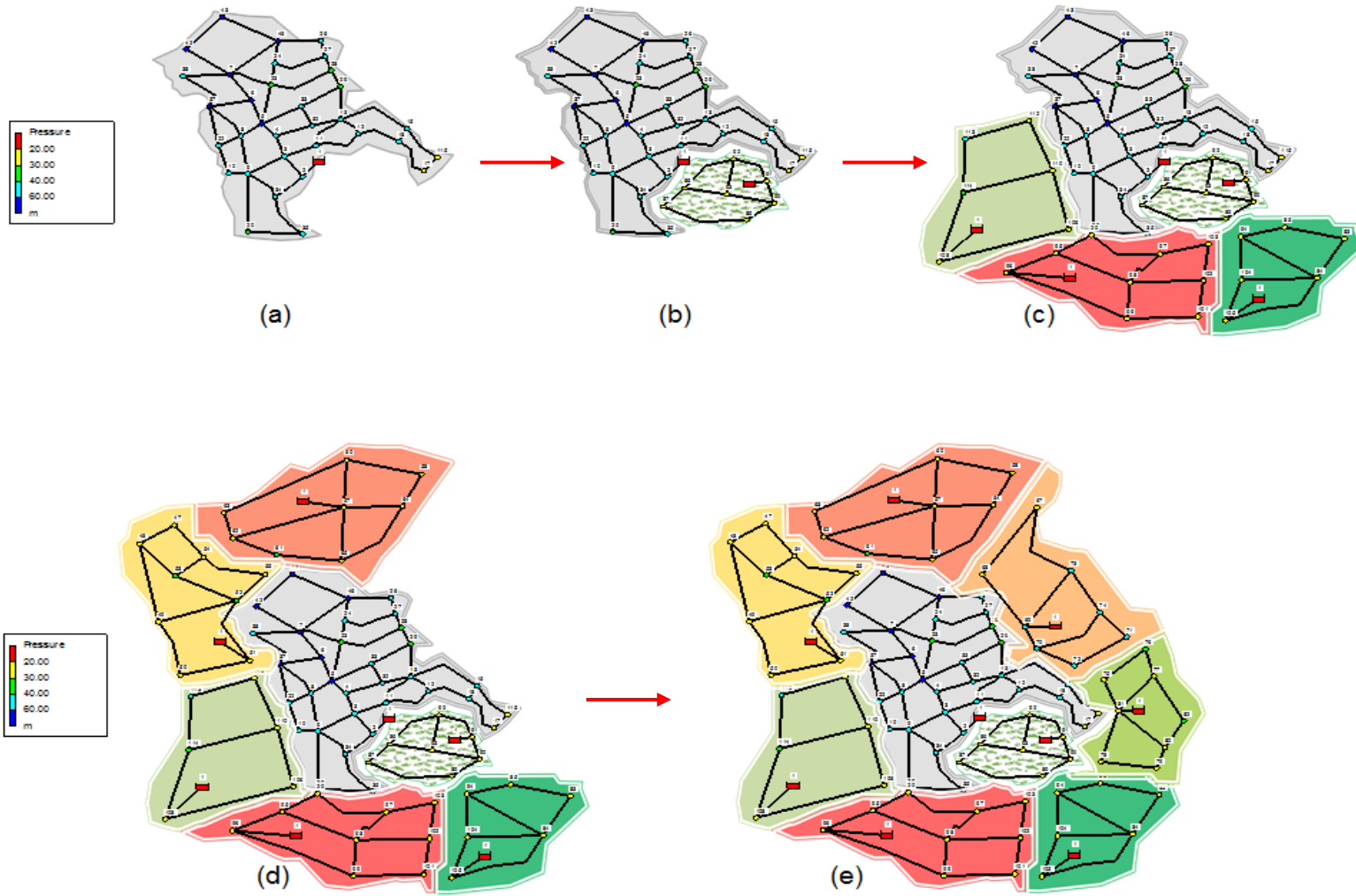

Figure 7.15 Staged development of clustered WDS for Arua town (scenario A<sub>1</sub>T<sub>0</sub>- A<sub>2</sub>T<sub>1</sub>- A<sub>3</sub>T<sub>2</sub>- A<sub>4</sub>T<sub>3</sub>-A<sub>5</sub>T<sub>4</sub>: (a) Year T<sub>0</sub> (b) Year T<sub>1</sub>; (c) Year T<sub>2</sub>; (d) Year T<sub>3</sub> (e) Year T<sub>4</sub>)



Table 7.5 Cost of clustered WDN

Scenario No.	Scenario	Clustered WDS (US\$)
1	A <sub>1</sub> T <sub>0</sub> - A <sub>1</sub> T <sub>1</sub> - A <sub>1</sub> T <sub>2</sub> - A <sub>1</sub> T <sub>3</sub> - A <sub>1</sub> T <sub>4</sub>	687,977
2	A <sub>1</sub> T <sub>0</sub> - A <sub>1</sub> T <sub>1</sub> - A <sub>1</sub> T <sub>2</sub> - A <sub>1</sub> T <sub>3</sub> - A <sub>2</sub> T <sub>4</sub>	750,619
3	A <sub>1</sub> T <sub>0</sub> - A <sub>1</sub> T <sub>1</sub> - A <sub>1</sub> T <sub>2</sub> - A <sub>2</sub> T <sub>3</sub> - A <sub>2</sub> T <sub>4</sub>	760,596
4	A <sub>1</sub> T <sub>0</sub> - A <sub>1</sub> T <sub>1</sub> - A <sub>2</sub> T <sub>2</sub> - A <sub>2</sub> T <sub>3</sub> - A <sub>2</sub> T <sub>4</sub>	772,163
5	A <sub>1</sub> T <sub>0</sub> - A <sub>2</sub> T <sub>1</sub> - A <sub>2</sub> T <sub>2</sub> - A <sub>2</sub> T <sub>3</sub> - A <sub>2</sub> T <sub>4</sub>	785,571
6	A <sub>1</sub> T <sub>0</sub> - A <sub>2</sub> T <sub>1</sub> - A <sub>2</sub> T <sub>2</sub> - A <sub>2</sub> T <sub>3</sub> - A <sub>3</sub> T <sub>4</sub>	1,029,357
7	A <sub>1</sub> T <sub>0</sub> - A <sub>2</sub> T <sub>1</sub> - A <sub>2</sub> T <sub>2</sub> - A <sub>3</sub> T <sub>3</sub> - A <sub>3</sub> T <sub>4</sub>	1,068,186
8	A <sub>1</sub> T <sub>0</sub> - A <sub>2</sub> T <sub>1</sub> - A <sub>3</sub> T <sub>2</sub> - A <sub>3</sub> T <sub>3</sub> - A <sub>3</sub> T <sub>4</sub>	1,113,199
9	A <sub>1</sub> T <sub>0</sub> - A <sub>2</sub> T <sub>1</sub> - A <sub>3</sub> T <sub>2</sub> - A <sub>3</sub> T <sub>3</sub> - A <sub>4</sub> T <sub>4</sub>	1,336,780
10	A <sub>1</sub> T <sub>0</sub> - A <sub>2</sub> T <sub>1</sub> - A <sub>3</sub> T <sub>2</sub> - A <sub>4</sub> T <sub>3</sub> - A <sub>4</sub> T <sub>4</sub>	1,372,391
11	A <sub>1</sub> T <sub>0</sub> - A <sub>2</sub> T <sub>1</sub> - A <sub>3</sub> T <sub>2</sub> - A <sub>4</sub> T <sub>3</sub> - A <sub>5</sub> T <sub>4</sub>	1,504,730

According to the NPV depicted in Table 7.4 and Table 7.5, the investment cost of a centralized WDS is higher than that of a clustered system. The proposed clustered WDS offers 24% to 34% cost savings (over a range of eleven scenarios) when compared to the centralized WDS. However, cost alone does not guarantee flexibility of a WDS. The flexibility of a WDS depends on its capability to react and respond to future changes and uncertainties. In the next subsection, this study applies the framework developed in Chapter 3 to evaluate the flexibility of both centralized and clustered systems.

#### 7.4.2 Assessing Flexibility of Clustered and Centralized WSS

The Capability to respond ( $C_{rs}$ ) is represented by the ratio of the range of responses ( $U_{rs}$ ) to the optimized cost of change  $C_c$  for the WDS options under different scenarios. Figure 7.16 and Figure 7.17 show the  $U_{rs}$  and  $C_c$  of a centralized and clustered WDS, respectively.

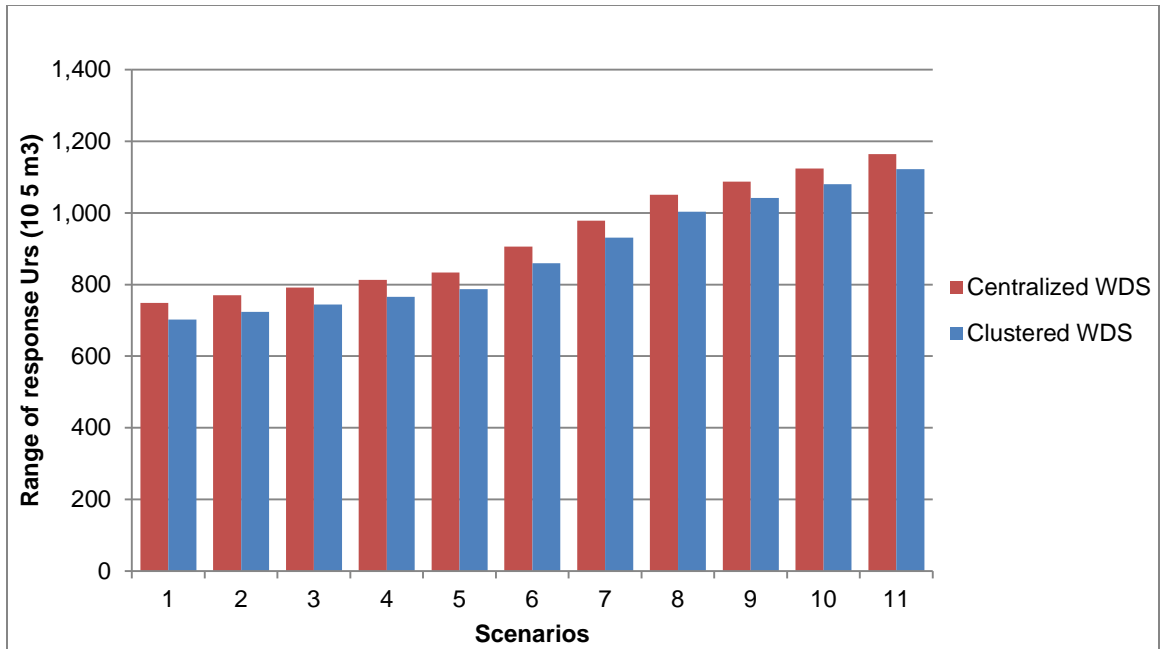

Figure 7.16 Range of response for centralized and clustered WDS

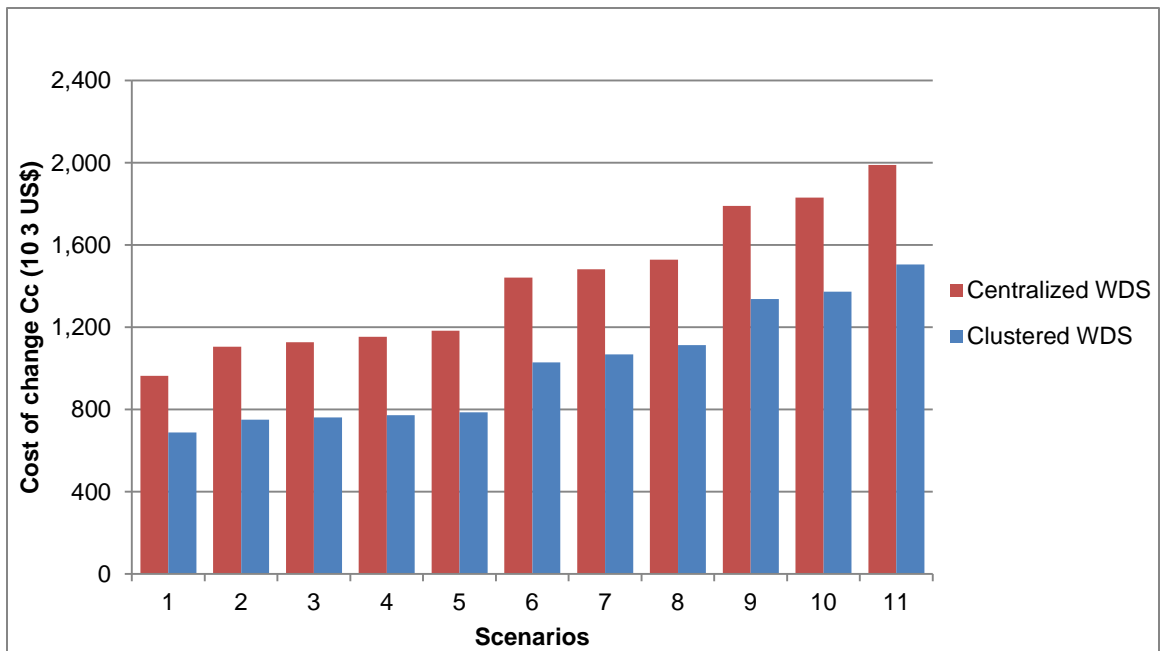

Figure 7.17 Cost of change for centralized and clustered WDS

As shown in Figure 7.16, the centralized conventional WDS, which is designed based on deterministic assumptions, is over-designed to absorb future changes and uncertainties. This means that the range of responses of the conventional WDS is larger than the range of responses of the Clustered WDS. However, this larger range also incurs greater costs ( $C_c$ ) than the clustered WDS as shown in Figure 7.17.

The range of response  $U_{rs}$  values shown in Figure 7.16, and the cost of change  $C_c$  values shown in Figure 7.17 are used to calculate the capability to respond  $C_{rs}$  of each WDS design under different scenarios and these values are summarized in Table 7.6.

Table 7.6  $C_{rs}$  value for centralized and clustered WSS

Scenario No.	Scenario	$C_{rs}$ (m3 /US\$)	
		Centralized	Clustered
1	$A_1T_0 - A_1T_1 - A_1T_2 - A_1T_3 - A_1T_4$	77.7	102.0
2	$A_1T_0 - A_1T_1 - A_1T_2 - A_1T_3 - A_2T_4$	69.7	96.4
3	$A_1T_0 - A_1T_1 - A_1T_2 - A_2T_3 - A_2T_4$	70.2	97.9
4	$A_1T_0 - A_1T_1 - A_2T_2 - A_2T_3 - A_2T_4$	70.5	99.2
5	$A_1T_0 - A_2T_1 - A_2T_2 - A_2T_3 - A_2T_4$	70.5	100.2
6	$A_1T_0 - A_2T_1 - A_2T_2 - A_2T_3 - A_3T_4$	62.9	83.5
7	$A_1T_0 - A_2T_1 - A_2T_2 - A_3T_3 - A_3T_4$	66.0	87.2
8	$A_1T_0 - A_2T_1 - A_3T_2 - A_3T_3 - A_3T_4$	68.7	90.1
9	$A_1T_0 - A_2T_1 - A_3T_2 - A_3T_3 - A_4T_4$	60.8	77.9
10	$A_1T_0 - A_2T_1 - A_3T_2 - A_4T_3 - A_4T_4$	61.5	78.7
11	$A_1T_0 - A_2T_1 - A_3T_2 - A_4T_3 - A_5T_4$	58.8	74.6

The results in Table 7.6 shows that clustered WDS, designed based on the principles of flexibility, is capable of responding to future scenarios that the centralized WDS designed based on conventional approaches. This is because the centralized WDS incurs a large cost associated with the excess capacity of the system.

The *Capability to react* ( $C_{ra}$ ) is represented by the ratio of the range of uncertainties that the WDS can handle ( $U_{ra}$ ) to the effort required to adapt ( $C_a$ ). The range of adaptation values, as well as the cost of these adaptation values, is plotted in Figure 7.18 and Figure 7.19.

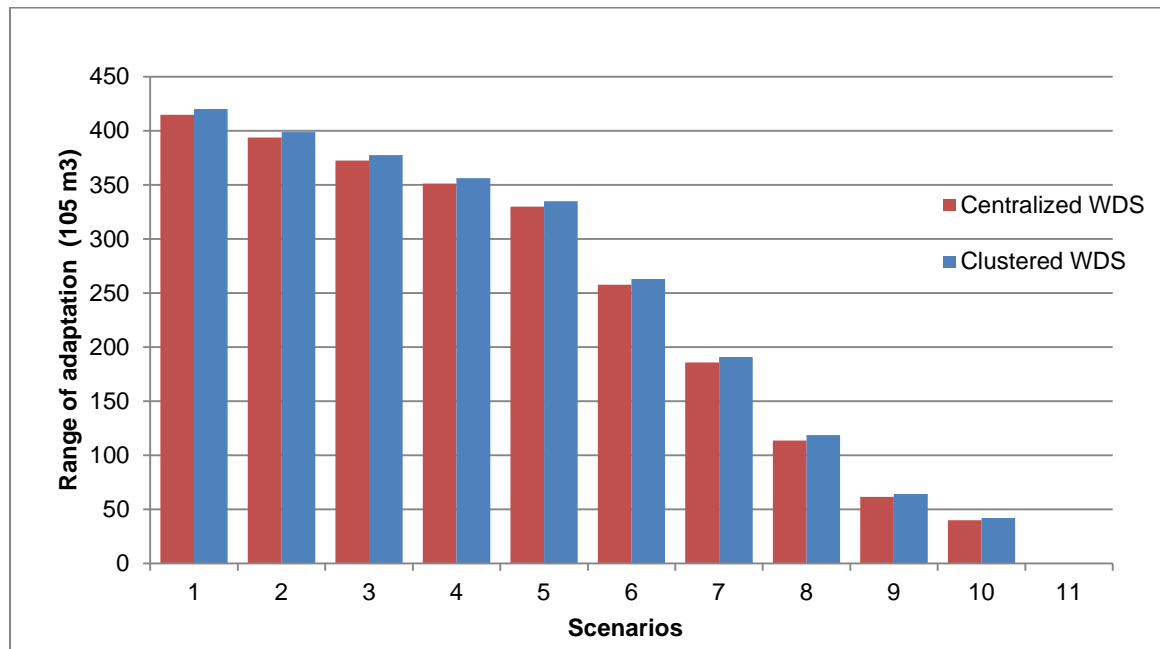

Figure 7.18 Range of adaptation for centralized and clustered WDS

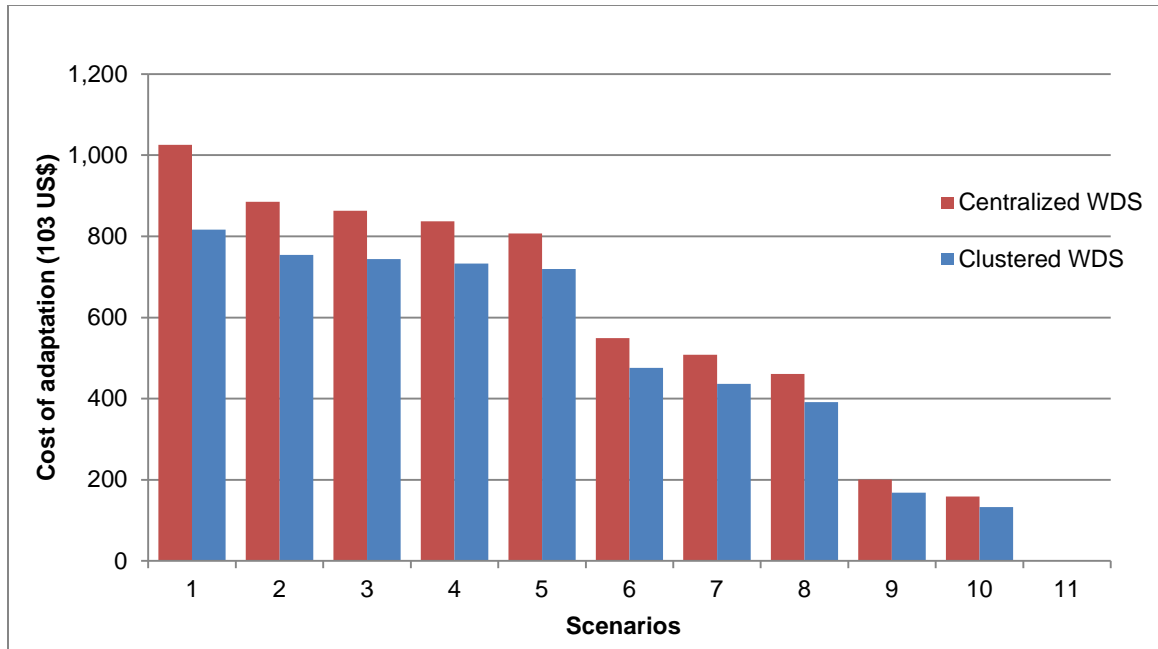

Figure 7.19 Cost of adaptation associated with each WDS design option

As shown in Figure 7.18 the centralized conventional WDS is required to adapt to a small range, as it was over-designed. Because the  $U_{ra}$  of the centralized WDS to the future changes is smaller than that of the clustered WDS, the  $C_a$  to the smaller range is likewise smaller (see and Figure 7.19). The values from Figure 7.18 and Figure 7.19 are used to calculate the  $C_{ra}$  value for each WDS alternatives. The  $C_{ra}$  for all decision paths is calculated using the method developed in Chapter 3, and the results are summarized in Table 7.7.

Table 7.7  $C_{ra}$  values of centralized and clustered WDS

Scenario No.	Scenario	$C_{ra}$ (m <sup>3</sup> /US\$)	
		Centralized	Clustered
1	A <sub>1</sub> T <sub>0</sub> - A <sub>1</sub> T <sub>1</sub> - A <sub>1</sub> T <sub>2</sub> - A <sub>1</sub> T <sub>3</sub> - A <sub>1</sub> T <sub>4</sub>	40.5	51.4
2	A <sub>1</sub> T <sub>0</sub> - A <sub>1</sub> T <sub>1</sub> - A <sub>1</sub> T <sub>2</sub> - A <sub>1</sub> T <sub>3</sub> - A <sub>2</sub> T <sub>4</sub>	44.5	52.9
3	A <sub>1</sub> T <sub>0</sub> - A <sub>1</sub> T <sub>1</sub> - A <sub>1</sub> T <sub>2</sub> - A <sub>2</sub> T <sub>3</sub> - A <sub>2</sub> T <sub>4</sub>	43.2	50.7
4	A <sub>1</sub> T <sub>0</sub> - A <sub>1</sub> T <sub>1</sub> - A <sub>2</sub> T <sub>2</sub> - A <sub>2</sub> T <sub>3</sub> - A <sub>2</sub> T <sub>4</sub>	42.0	48.6
5	A <sub>1</sub> T <sub>0</sub> - A <sub>2</sub> T <sub>1</sub> - A <sub>2</sub> T <sub>2</sub> - A <sub>2</sub> T <sub>3</sub> - A <sub>2</sub> T <sub>4</sub>	40.9	46.6
6	A <sub>1</sub> T <sub>0</sub> - A <sub>2</sub> T <sub>1</sub> - A <sub>2</sub> T <sub>2</sub> - A <sub>2</sub> T <sub>3</sub> - A <sub>3</sub> T <sub>4</sub>	46.9	55.3
7	A <sub>1</sub> T <sub>0</sub> - A <sub>2</sub> T <sub>1</sub> - A <sub>2</sub> T <sub>2</sub> - A <sub>3</sub> T <sub>3</sub> - A <sub>3</sub> T <sub>4</sub>	36.5	43.7
8	A <sub>1</sub> T <sub>0</sub> - A <sub>2</sub> T <sub>1</sub> - A <sub>3</sub> T <sub>2</sub> - A <sub>3</sub> T <sub>3</sub> - A <sub>3</sub> T <sub>4</sub>	24.7	30.3
9	A <sub>1</sub> T <sub>0</sub> - A <sub>2</sub> T <sub>1</sub> - A <sub>3</sub> T <sub>2</sub> - A <sub>3</sub> T <sub>3</sub> - A <sub>4</sub> T <sub>4</sub>	30.7	38.3
10	A <sub>1</sub> T <sub>0</sub> - A <sub>2</sub> T <sub>1</sub> - A <sub>3</sub> T <sub>2</sub> - A <sub>4</sub> T <sub>3</sub> - A <sub>4</sub> T <sub>4</sub>	25.2	31.8
11	A <sub>1</sub> T <sub>0</sub> - A <sub>2</sub> T <sub>1</sub> - A <sub>3</sub> T <sub>2</sub> - A <sub>4</sub> T <sub>3</sub> - A <sub>5</sub> T <sub>4</sub>	0.0	0.0

The results in Table 7.7 show that clustered WDS, designed based on the flexibility principles, has a higher capability to react ( $C_{ra}$ ) to uncertain future scenarios. This is because the effort required to adapt to a unit range of future change is smaller for the clustered system as they are modular and adaptable units than conventional centralized WDS. However, scenario 8 (A<sub>1</sub>T<sub>0</sub>- A<sub>2</sub>T<sub>1</sub>- A<sub>3</sub>T<sub>2</sub>- A<sub>4</sub>T<sub>3</sub>) is based on the maximum possible future demand, and both WDS-1 and WDS-2 designed for this scenario are not required to adapt to any scenario.

*Level of flexibility* ( $F_{opt}$ ) is used to determine the flexibility of centralized and clustered WDS options. Figure 7.20 shows  $F_{opt}$  values based on an equal weighting factor for  $C_{ra}$  and  $C_{rs}$  in terms of each WDS option under different scenarios.

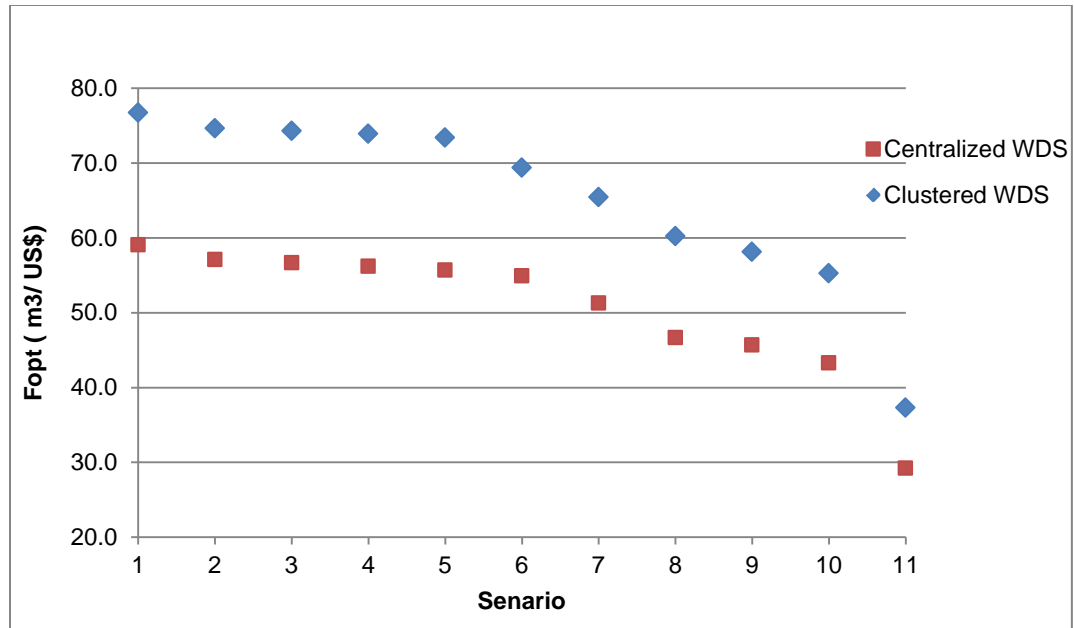

Figure 7.20 The optimal flexibility value for centralized and clustered WSS

The results in Figure 7.20 illustrates that clustered WDS has a high flexibility value and performs better under all scenarios than centralized WDS. It also shows that the value of flexibility for the system designed using GAFO (clustered) is greater for the smaller scenarios (i.e scenario 1) than for the worst scenario (i.e scenario 11). This is because if the future condition becomes the worst scenario, the value added by the flexible system will be smaller. The regret associated under each scenarios and the decision for selection is presented in the next subsection.

The flexibility value of the two options is compared using a *minimax* regret decision making approach which is based on the future regret associated with

the present decision. A sample calculation of the regret associated with the different options under scenario-A is shown below.

$$f_{R(\text{centralized})} = \max\{F_{\text{opt}(i,j)}\} - F_{\text{opt}(i,j)} = 76.7 - 59.1 = 17.7$$

$$f_{R(\text{clustered})} = 76.7 - 76.7 = 0$$

The regret for each alternative for all other scenarios is calculated using the same approach, and the results are summarized in Table 7.8 The lowest value of maximum regret for each option is then considered as the preferred alternative in terms of the cost of change.

Table 7.8 Regret associated with the different design options

Scenario No.	Scenario	Regret with respect to $F_{\text{opt}}$ ( $\text{m}^3/\text{US\$}$ ) ( $\text{m}^3/\text{US\$}$ )	
		Centralized	Clustered
1	$A_1T_0 - A_1T_1 - A_1T_2 - A_1T_3 - A_1T_4$	17.7	0.0
2	$A_1T_0 - A_1T_1 - A_1T_2 - A_1T_3 - A_2T_4$	17.5	0.0
3	$A_1T_0 - A_1T_1 - A_1T_2 - A_2T_3 - A_2T_4$	17.6	0.0
4	$A_1T_0 - A_1T_1 - A_2T_2 - A_2T_3 - A_2T_4$	17.7	0.0
5	$A_1T_0 - A_2T_1 - A_2T_2 - A_2T_3 - A_2T_4$	17.7	0.0
6	$A_1T_0 - A_2T_1 - A_2T_2 - A_2T_3 - A_3T_4$	14.5	0.0
7	$A_1T_0 - A_2T_1 - A_2T_2 - A_3T_3 - A_3T_4$	14.2	0.0
8	$A_1T_0 - A_2T_1 - A_3T_2 - A_3T_3 - A_3T_4$	13.6	0.0
9	$A_1T_0 - A_2T_1 - A_3T_2 - A_3T_3 - A_4T_4$	12.4	0.0
10	$A_1T_0 - A_2T_1 - A_3T_2 - A_4T_3 - A_4T_4$	12.0	0.0
11	$A_1T_0 - A_2T_1 - A_3T_2 - A_4T_3 - A_5T_4$	8.0	0.0
<b>Maximum regret</b>			
<b>Minimax regret</b>			



Based on the *minimax* regret analysis above, the clustered WDS has a lower regret associated with the potential future conditions in comparison to a centralized WDS. Thus, this case study has verified that clustered systems provide higher flexibility than centralized WDS. The gradual stepwise development of clustered systems enables the expansion or deferral of WDS in correspondence with spatial growth. Therefore, clustered WDS have a better ability to cope with the uncertainties of spatial growth than conventional centralized systems. In addition to flexibility, in this study an overall cost comparison (in NPV) between clustered and centralized supply system is performed and presented in Appendix 2 to Appendix 4. The comparison includes investment costs associated with water collection pipes, water distribution network, reservoirs and water treatment plants, and operation and maintenance costs such as pumping and water treatment. The result shows that the clustered water supply system is cheaper than centralized water supply system (see Appendix 4)

## **7.5 Conclusions: Flexibility of Clustered WDS**

This chapter presents the applications of the developed clustering methodology in chapter 6 to a real world case study in Arua, Uganda. The WDS in Arua is divided into nine clusters thereby reducing the effort required to move water and wastewater, as well as developing systems that offer opportunity to adapt to future changes. The case study demonstrated that it is possible to apply

the developed methodology to develop clusters based on minimization the distance between source and use, and maximizing the intra-cluster homogeneity.

In addition this chapter assessed the flexibility of decentralized and clustered WDS against future changes and uncertainties and compared it with a conventional centralized WDS. The overall cost (NPV) comparison shows that a decentralized clustered WDS offers a cost reduction of 24%-34% (for a range of five scenarios) and that these cost savings are associated with the ability of the decentralized system to be staged in such a way that the system traces the urban growth trajectory more closely. Based on a minimax regret analysis, a decentralized clustered WDS has shown a lower regret (a difference of 17.7m<sup>3</sup>/US\$) associated with its flexibility to deal with the potential future conditions than a conventional centralized system. This chapter has verified that a decentralized clustered WDS has a better ability to cope with the uncertainties of spatial growth than conventional centralized systems.

## 8 Conclusions and Recommendations

The main conclusion of this research is that the deterministic assumptions used when designing water distribution systems is no longer valid due to the inherent uncertainties associated with global change pressures. Hence there is a need to develop new approaches and methodologies that recognize these inherent uncertainties and develop more adaptable and flexible systems that have the ability to use their active capacity to act or respond to future alterations in a timely, performance-efficient and cost-effective manner.

In order to effectively design flexible WDS it is important to effectively articulate the uncertainties against which the system is being designed. Scenario trees are well suited for this purpose. To assess the degree of flexibility of different designs, it is important to develop appropriate performance metrics. These metrics should include components that capture the capability of the distribution system to respond and react to change. These metrics can then be used to inform and influence the design of a flexible WDS and should be hence evaluated using appropriate rules of decision making under uncertainty, such as the minimax regret rule.

As WDS are large and complex, and their design can often be counter-intuitive, it is important to utilize formal optimization techniques to help identify an optimal design. However, the optimization model should recognize the duality of maximizing flexibility at the least cost. In addition, the optimization should be able to generate flexible, staged development plans for the incremental growth of WDS. Similarly there is a growing consensus that decentralized/clustered systems promote greater flexibility as they provide internal degrees of freedom, allowing different combinations of distribution systems to be considered so that their flexibility can be optimized over time. Hence any methodology developed for flexibility should support development of decentralized distribution systems.

In this study, a framework is developed and applied for the design of flexible WDS that are adaptable to new, different, or changing requirements. The framework consists of several components including: an uncertainty model based on scenario trees; a suite of performance metrics that allow an assessment of the degree of flexibility of a distribution system; a tailor-made decision making framework based on the minimax regret principle. In addition two optimization models are developed to maximize the flexibility of a WDS at the least cost. The first considers the design of centralized WDS's and the second is an optimization model for clustering of WDS. Both models provide flexibility by allowing gradual development of the systems. The sections below will summarize and provide conclusions on the various components of the framework.

## 8.1 Framework for Design of Flexible WDS

The development of the framework involved four major steps: description of uncertainties affecting WDS design; identification of potential options for WDS for enhancing flexibility; the generation of flexibility; and rules for decision making under uncertainty.

In this dissertation, a scenario approach was used to describe potential future uncertain states of a WDS as this does not require the formal description of probabilities associated with anticipated change. The scenarios are generated based on possible future change drivers and their associated uncertainties and these scenarios are articulated through the development of scenario trees. The conclusion of this research is that scenario trees are helpful in reflecting the possible future states of WDS in a simple manner, while capturing the impact of uncertainties on the design of these future states.

Different typologies of options that enhance flexibility of the WDS are identified in this dissertation. WDS options can best be categorized into three main groups. *System design* options are technical possibilities that allow designers to modify a system to adapt to the future change requirements. These options include platform design, stage design, and clustered design. *System management* options are ones that increase the ability of planners/decision makers to implement different management decisions at different times. These options include investment deferral, multistage deployment, and expansion.

*System element* options are physical, flexible elements or combinations of elements within a WDS that deliver better flexibility. These physical elements include valves, pipes, pumps and reservoirs.

When generating flexibility it is important to think about the degree of flexibility (a spectrum varying from totally inflexible to partially flexible to fully flexible). The degree of flexibility also impacts cost and hence it is important to consider a multi-objective problem where one attempts to maximize flexibility at the least cost. In this dissertation a GA based flexibility optimization (GAFO) model for centralized WDS is developed as well as an optimization tool for the flexible, design of decentralized/clustered WDS is developed. Depending on the nature of the problem the appropriate optimization model for centralized or for decentralized/clustered WDS has to be selected. The application of the developed optimization models, which build the core of the framework, will be discussed in detailed in sections 8.2 and 8.3 below.

Since different flexible design alternatives (based on different flexible options) could be generated using the GAFO model, the framework incorporates a post-optimization flexibility assessment. In this case two new performance metrics were developed: *capability to respond* and *capability to react*. *Capability to respond* is the capability of the WDS to absorb specific future alterations. This flexibility dimension indicates the intended degree of change that embedded options allow for the system to cope with future changes without change

requirement. *Capability to react* is the capability of the WDS to react to unknown future alterations. This dimension indicates the nature and degree of change (in response to unknown future alterations) that the system is able to adapt to, beyond what it was designed for. These metrics are then combined in to a single metric called the 'optimal level of flexibility' metric. These metrics are used for decision making under uncertainty as they allow assessment of the extent of flexibility of a WDS with respect to their capability to respond and react to future uncertainties.

The dissertation concludes that a *minimax* regret rule is valuable for flexibility-based decision-making for WDS alternatives. This rule is based on "fear of guilt" principle that reduces the chance that an outcome will turn disappointing or regretful. In this study a *minimax* regret rule was developed where the regret is described in terms of the opportunity loss of WDS alternatives, associated with flexibility. The opportunity loss is defined as the difference between the maximum possible flexibility and the flexibility of each alternative. Hence, the lower the level of regret associated with an alternative, the greater its flexibility. Through case study applications, the dissertation demonstrated the usefulness of such an approach.

## 8.2 Optimization of Centralized WDS for Flexibility

In this dissertation, a new optimization model is developed for the flexible design of centralized WDS. The new model is called GAFO (Genetic Algorithm based Flexibility Optimization) and was coded in C++.

The objective function developed in the GAFO model focuses on the minimization of investment and adaptation costs associated with responding to a changing environment. The objective function is optimized subject to constraints that ensure system performance at all stages of the implementation of the design. The unique feature of GAFO is that it allows flexibility to be embedded into a WDS design as the optimization is performed against all possible future scenarios. The outcome of the optimization is that it develops a WDS that can follow different trajectories (based on future conditions) and hence generates a staged implementation strategy that allows a stepwise evolution of the WDS over time.

GAFO employs a genetic algorithm process for the optimization. However, unlike traditional GA optimization, GAFO involves a dynamic decision-making process that recognizes a range of possible future conditions through a scenario tree and explores this tree to maximize the changeability of the WDS. Hence the developed GAFO model includes a unique nested loop process that optimizes across several future states and stages, described by the scenario tree. It should be noted that the dynamic decision-making process involves a decision at each



time stage, and that each decision is influenced by the decision made at the previous time stage. The GAFO model was tested on several hypothetical case studies and was found to perform well in terms of convergence and in terms of flexible design solutions where cost savings in the range of 14% to 72% were realized (compared with conventional, non-flexible designs).

The GAFO model was applied for the design of a flexible centralized WDS in Mbale, a small town in Eastern Uganda. In this case study two major uncertainties were considered: changes in water consumption patterns; and changes in the spatial growth of the town. Based on these two uncertainties, eight possible future scenarios were developed and flexible designs were generated that allowed staged changes to occur so as to respond to the predicted changes. Flexibility was embedded into the design through the addition of parallel pipes to the system in response to future growth. The optimization results of this application showed that considering several future scenarios, the flexibility framework was able to generate a flexible staged design that was cheaper than a conventional designed system. The costs of the flexible design were 4% – 50% cheaper than the conventional design. In addition, the flexibility of the designed system was evaluated using the *minimax* regret principle and the results of this highlighted that the flexible design has a lower regret compared to the conventionally designed system (a difference of 11m<sup>3</sup>/US\$).

### 8.3 Optimization of Clustered WDS for Flexibility

In this dissertation an optimization model is developed that supports development of decentralized distribution systems. It is argued that these clustered systems promote flexibility as they provide internal degrees of freedom, allowing many different combinations of distribution systems to be considered so that their flexibility can be optimized over time (Webster et al., 2012; Bieker et al., 2010, PSGS, 2010). To the best of the authors knowledge, currently there is no a well-developed methodology for clustering WDS. The clustering optimization model is based on two objectives: minimization of the distance from a source to consumer; maximization of the homogeneity within a cluster by minimizing the variation in cluster characteristics (population density, land-use, socio-economic level and topography). The model employed a Euclidean distance minimization approach to cluster available local sources and assign demand to the closest source center, and K-means approach to maximize the intra-cluster homogeneity.

The developed model is applied to real case study in Arua, Uganda. The flexibility of the clustered WDS against future changes and uncertainties was assessed and compared with the flexibility of conventional centralized WDS. To verify the flexibility of clustered systems, the GAFO model was also applied to the design of Arua water supply system.

The overall cost comparison shows that decentralized clustered WDS offer a cost reduction of 24% - 34% (for a range of eleven scenarios) and that these cost savings are associated with the ability of the decentralized system to be staged in a way that traces the urban growth trajectory more closely. The flexibility of the clustered system is analyzed using a *minimax* regret analysis approach and it is found that the clustered WDS has a lower regret (a difference of 17m<sup>3</sup>/US\$) associated with the flexibility.

#### 8.4 Future Potential Research

Although this research has been extensive and complete, as with other PhD's, time is limited and hence many interesting areas of exploration were not considered. As the research undertaken in this study is very new and the topic of flexibility is still in its infancy, it is recommended that further research is encouraged in this important area. Specific areas of research that could be considered include the following:

- i) This study has limited the uncertainty parameters under consideration to water demand. It is recommended that further research be undertaken to extend the developed models to other uncertain parameters such as pipe aging and deterioration, mixed land-use, water quality etc.
- ii) In this study, a suite of options are explored and embedded into the flexible design of WDS. However a pre-identification and prioritization of flexible options that offer better life flexibility is required. Several

disciplines have attempted to develop a method for pre-prioritization of flexibility options but this has not been done for WDS.

- iii) This study developed a model for the decentralization of WDS and showed cost and flexibility related benefits compared to centralized systems. However there is a need for further research on determination of the optimal size of clusters, the resulting decentralized closed loop water systems and the potential benefits of interactions between clusters.
- iv) The focus of this study has been on flexibility design for new WDS. However, it is recognized that it is important to consider existing WDS and to develop methods for them to transition to a more flexible state. This will include identifying optimal transitional pathways that allows a staged transition from a highly centralized inflexible system, to a more decentralized flexible one.

## References

- Allen, T., Moses, J., Hastings, D., Lloyd, S., Little, J., McGowan, D., Magee, C., Moavenzadeh, F., Nightingale, D., Roos, D., and Whitney, D. (2001) ESD Terms and Definitions. Massachusetts Institute of Technology, Engineering Systems Division.
- Alperovits, E. and Shamir, U. (1977). "Design of optimal water distribution systems." *Water resources research* **13**(6): 885-900.
- Al-Saleh, M. F., and Yousif, A. E. (2009) Properties of the Standard Deviation that are Rarely Mentioned in Classrooms. *Australian Journal of Statistics*, **38**, 193-202.
- Arboleda, C. A., and Abraham, D. M. (2006) Evaluation of flexibility in capital investments of infrastructure systems. *Engineering Construction and Architectural Management*, **13**(3), 254.
- Arbues, F., Garcia-Valinas, M. A., and Martinez-Espineira, R. (2003) Estimation of residential water demand: a state-of-the-art review. *Journal of Socio-economics*, 32(1), 81-102.
- Awumah, K., and Goulter, I. (1992) Maximizing entropy defined reliability of water distribution networks. *Engineering optimization*, **20**(1), 57-80.
- Babayan, A. V., Savic, D. A., and Walters, G. A. (2007) Multiobjective optimization of water distribution system design under uncertain demand and pipe roughness. *Topics on system analysis and integrated water resource management*, 161.
- Babayan, A., Kapelan, Z., Savic, D., and Walters, G. (2005) Least-Cost Design of Water Distribution Networks under Demand Uncertainty. *Journal of Water Resources Planning and Management*, **131**(5), 375-382.
- Back, T., and Hoffmeister, F. (1991) Extended selection mechanisms in genetic algorithms. *Proceedings of the Fourth International Conference on Genetic Algorithms and Their Applications*, 92-99.
- Beard, L. R. (1982) Flexibility - a key to the management of risk and uncertainty in water supply. *Optimal Allocation of Water Resources*

- Bell, D. E. (1982) Regret in decision making under uncertainty. *Operations research*, 961-981.
- Bernanke, B. S. (1983) Irreversibility, uncertainty, and cyclical investment. *The Quarterly Journal of Economics*, **98**(1), 85-106.
- Bieker, S., Cornel, P., and Wagner, M. (2010) Semicentralised supply and treatment systems: integrated infrastructure solutions for fast growing urban areas. *Water science and technology: a journal of the International Association on Water Pollution Research*, **61**(11).
- Blickle, T. (1995) YAGPLIC-User Manual. *Computer Engineering and Communication Networks Lab (TIK), Swiss Federal Institute of Technology (ETH) Zurich, Gloristrasse*, **35**.
- Blickle, T., and Thiele, L. (1995) A mathematical analysis of tournament selection. *Proceedings of the Sixth International Conference on Genetic Algorithms*, 9-16.
- BMBF (2006) *Semicentralized supply and disposal systems for fast growing urban regions in China*, Final report of Sino-German Research Project. German Federal Ministry of Science and Technology.
- Böhm, H. R., Schramm, S., Bieker, S., Zeig, C., Anh, T. H., and Thanh, N. C. (2011) The semicentralized approach to integrated water supply and treatment of solid waste and wastewater—a flexible infrastructure strategy for rapidly growing urban regions: the case of Hanoi/Vietnam. *Clean Technologies and Environmental Policy*, **13**(4), 617-623.
- Brest, J., and Maucec, M. S. (2008) Population size reduction for the differential evolution algorithm. *Applied Intelligence*, **29**(3), 228-247.
- Cardin, M.-A., and Neufville, R. d. (2008) A Survey of State-of-the-Art Methodologies and a Framework for Identifying and Valuing Flexible Design Opportunities in Engineering Systems. Massachusetts Institute of Technology, Cambridge.
- Chan, C., Wong, C., Cheung, S., and Tang, N. (2002) Genetic algorithms in multi-stage portfolio optimization system. *In proceedings of the eighth international conference of the Society for Computational Economics, Computing in Economics and Finance*, Aix-en-Provence, France.
- Chen, R., and Wang, X. (2009) Cost-benefit evaluation of a decentralized water system for wastewater reuse and environmental protection. *Water science and technology*, **59**(8), 1515-1522.
- COWATER (2005) District Town Sewerage /Sanitation Feasibility study: Arua master plan, National Water and Sewerage Corporation, Uganda.

- Crow, J. F., and Kimura, M. (1970) *An introduction to population genetics theory*, Harper and Row, New York.
- de Neufville, R. (2000) Dynamic strategic planning for technology policy. *International Journal of Technology Management*, **19**(3), 225-245.
- de Neufville, R. (2001) Real options: dealing with uncertainty in systems planning and design. *5th. International Conference on "Technology Policy and Innovation"*, Delft University of Technology, Delft, Netherlands.
- de Neufville, R. (2002) *Architecting/Designing Engineering Systems Using Real Options*. Monograph, Engineering Systems Division Internal Symposium, Massachusetts Institute of Technology. [Online] [Access date: Jan]
- de Neufville, R. (2004) Uncertainty Management For Engineering Systems Planning And Design. *Engineering Systems Monograph*, Cambridge, MA.
- de Neufville, R., and Cardin, M. ( 2008) A Survey of State-of-the-Art Methodologies and a Framework for Identifying and Valuing Flexible Design Opportunities in Engineering Systems. Working Paper, Cambridge MA.
- de Weck, O. L., and Suh, E. S. (2005) *Flexible product platforms*, Massachusetts Institute of Technology.
- Dettinger, M. D. and J. L. Wilson (1981). "First Order Analysis of Uncertainty in numerical models of groundwater flow, Mathematical Development." *Water Resources Research* 17(1): 149-16.
- Dijk, M. v., Vuuren, S. v., and Zyl, J. v. (2008) Optimising water distribution systems using a weighted penalty in a genetic algorithm. *Water SA*, **34** (5).
- Dopp, K. (2011) Legislative Redistricting-Compactness and Population Density Fairness. *Available at SSRN 1945879*.
- Eckart, J., Sieker, H., and Vairavamoorthy, K. (2010) Flexible Urban Drainage System. *Water Convention Singapore International Water Week*, Singapore
- Eckart, J., Tsegaye, S., and Vairavamoorthy, K. (2011) Measuring the flexibility of urban drainage systems. *The Future of Urban Water: Solutions for Livable and Resilient Cities, January 24th – 26th Paris*
- Eckert, C., Clarkson, P. J., and Zanker, W. (2004) Change and customisation in complex engineering domains. *Res Eng Des*, **15**(1), 1–21.
- Eiben, A. E., and Smith, J. E. (2003) *Introduction to evolutionary computing*, Springer Verlag.

- Einhorn, H. J., and Hogarth, R. M. (1986) Decision making under ambiguity. *Journal of Business*, 225-250.
- EPA (1999) Survey data, unit construction cost of traditional filter water treatment plants, US Environmental Protection Agency.
- Eppen, G. D., R. K. Martin, et al. (1989). "A scenario approach to capacity planning." *Operations Research*: 517-527.
- Kazi A S, Aouad G, and Baldwin A (2009). "Construction IT in 2030: a scenario planning approach." *Journal of Information Technology in Construction* 14: 539-555.
- Erlenkotter, D., Sethi, S., and Okada, N. (1989) Planning for surprise: Water resources development under demand and supply uncertainty I. The general model. *Management science*, **35**(2), 149-163.
- Espinoza, F. P., and Minsker, B. S. (2006) Development of the enhanced self-adaptive hybrid genetic algorithm (e-SAHGA). *Water resources research*, **42**(8), 8501.
- Farmani, R., Walters, G. A., and Savic, D. A. (2005) Trade-off between total cost and reliability for Anytown water distribution network. *Journal of water resources planning and management*, **131**, 161.
- Finne, T. (1998) The Three Categories of Decision Making and Information Security. *Computers and Security*, **17**(5), 397-405.
- Fricke, E., and Schulz, A. P. (2005) Design for changeability (DfC): Principles to enable changes in systems throughout their entire lifecycle. *Systems Engineering-New York*, **8**(4), 342.
- Fujiwara, O., and Ganesharajah, T. (1993) Reliability assessment of water supply systems with storage and distribution networks. *Water Resources Research*, **29**(8), 2917-2924.
- GAUFF (2011) *Arua Emergency Water Supply Project: Inception report*. [Online] [http://www.amk.rwth-aachen.de/uploads/media/RECLAIM\\_WATER\\_Publishable\\_Final\\_Activity\\_Report.pdf](http://www.amk.rwth-aachen.de/uploads/media/RECLAIM_WATER_Publishable_Final_Activity_Report.pdf) [Access date: July 2012]
- Giustolisi, O., Laucelli, D., and Colombo, A. F. (2009) Deterministic versus Stochastic Design of Water Distribution Networks. *Journal of Water Resources Planning and Management*, **135**(2), 117-127
- Goldberg, D. E., and Deb, K. (1991) A comparative analysis of selection schemes used in genetic algorithms. *Urbana*, **51**, 61801-2996.



- Gomes, H. P., de Tarso Marques Bezerra, S., De Carvalho, P. S. O., and Salvino, M. M. (2012) Optimal dimensioning model of water distribution systems. *Water SA*, **35**(4).
- Goulter, I. (1995) *Analytical and simulation models for reliability analysis in water distribution systems*, Norwell, MA: Kluwer.
- Goulter, I. C. (1987) Current and future use of systems analysis in water distribution network design. *Civil Engineering Systems*, 4(4), 175-184.
- Grefenstette, J. J., and Baker, J. E. (1989) How genetic algorithms work: A critical look at implicit parallelism. *Proceedings of the third international conference on Genetic algorithms*, 20-27.
- Gu, P., M. Hashemian, et al. (1997). "An integrated modular design methodology for life-cycle engineering." *CIRP Annals-Manufacturing Technology* **46**(1): 71-74.
- Gupta, I., Gupta, A., and Khanna, P. (1998) Genetic algorithm for optimization of water distribution systems. *Environmental Modelling & Software*.
- Halhal, D., Walters, G. A., Ouazar, D., and Savic, D. A. (1997) Water network rehabilitation with structured messy genetic algorithm. *Journal of Water Resources Planning and Management*, **123**(3), 137-146.
- Hassan, R., and de Neufville, R. (2006) Design of Engineering Systems under Uncertainty via Real Options and Heuristic Optimization. *Massachusetts Institute of Technology, unpublished paper*.
- Herrera, M., Canu, S., Karatzoglou, A., Perez-García, R., and Izquierdo, J. (2010) An approach to water supply clusters by semi-supervised learning. *Proceedings of iEMSs*.
- Hocke, S., and Heinzl, A. (2006) *Flexibilitätsmanagement – eine systemtheoretisch-kybernetische Betrachtung*. University of Mannheim, Department of Information Systems, Mannheim.
- Holland, J. (1975) *Adaptation in Natural and Artificial Systems*, University of Michigan Press, Ann Arbor.
- Huang, D., Vairavamoorthy, K., and Tsegaye, S. (2010) Flexible Design of Urban Water Distribution Networks *World Environmental & Water Resources Congress 2010*, Rhode Island, USA.
- Jacobs, P., and Goulter, I. (1988) Evaluation of methods for decomposition of water distribution networks for reliability analysis. *Civil Engineering Systems*, **5**(2), 58-64.

- Jacobs, P., and Goulter, I. C. (1989) Optimization of redundancy in water distribution networks using graph theoretic principles. *Engineering optimization*, **15**(1), 71-82.
- Kahneman, D., and Tversky, A. (1979) Prospect theory: An analysis of decision under risk. *Econometrica: Journal of the Econometric Society*, 263-291.
- Kalligeros, K. (2006) *Platforms and Real Options in Large-Scale Engineering Systems*, Massachusetts Institute of Technology, Cambridge, MA.
- Karatzas, G. P., and Finder, G. F. (1996) The solution of groundwater quality management problems with a nonconvex feasible region using a cutting plane optimization technique. *Water Resources Research*, **32**(4), 1091-1100.
- Kessler, A., and Shamir, U. (1989) Analysis of the linear programming gradient method for optimal design of water supply networks. *Water Resources Research*, **25**(7), 1469-1480.
- Khatri, K. B., and Vairavamoorthy, K. (2007) Challenges for urban water supply and sanitation in the developing countries. 81.
- Khosrowpanah, S., and Heitz, L. (2003) *Slow Sand Filter Conceptual Design for the Federated States of Micronesia (FSM)*, Water and Environmental Research Institute of the Western Pacific, University of Guam.
- Khu, S. T., and Keedwell, E. (2005) Introducing more choices (flexibility) in the upgrading of water distribution networks: the New York city tunnel network example. *Engineering Optimization*, **37**(3), 291-305.
- Kirkpatrick, S., Gelatt Jr, C. D., and Vecchi, M. P. (1983) Optimization by simulated annealing. *science*, **220**(4598), 671-680.
- Kleiner, Y. (1997) *Rehabilitation Planning of Water Distribution Networks: The Component and the System Perspective*, National Research Council Canada, Institute for Research in Construction.
- Lansey, K. E., and Mays, L. W. (1989) Optimization models for design of water distribution systems. *Reliability Analysis of Water Distribution Systems. American Society of Civil Engineers, New York*, 37-84.
- Lau, J., and Chan, J. (2004) *Strategic reasoning: Decision Theory*. School of Humanities, Faculty of Arts, The University of Hong Kong. [Online] <http://philosophy.hku.hk/think/strategy/decision.php> [Access date: December 2010]

- Lipshitz, R., and Strauss, O. (1997). Coping with uncertainty: A naturalistic decision-making analysis. *Organizational Behavior and Human Decision Processes*, **69**(2), 149-163.
- Lobo, F., and Lima, C. (2007) Adaptive population sizing schemes in genetic algorithms. *Parameter Setting in Evolutionary Algorithms*, 185-204.
- Lopez-Pujalte, C., Guerrero-Bote, V. P., and de Moya-Anegon, F. (2003) Order-based fitness functions for genetic algorithms applied to relevance feedback. *Journal of the American Society for Information Science and Technology*, **54**(2), 152-160.
- Lund, J. R. (1988) Regional water supply development in south Sweden. *Journal of Urban Planning and Development*, **114**(1), 14-33.
- Maier, H. R., Simpson, A. R., Zecchin, A. C., Foong, W. K., Phang, K. Y., Seah, H. Y., and Tan, C. L. (2003) Ant colony optimization for design of water distribution systems. *Journal of water resources planning and management*, **129**, 200.
- Maskey, S. and V. Guinot (2003). "Improved first-order second moment method for uncertainty estimation in flood forecasting." *Hydrological sciences journal* 48(2): 183-196.
- Mays, L. W. (2000) *Water Distribution Systems Handbook*, McGraw-Hill, New York., Tempe, Arizona.
- Ministry of Water and Environment (2011) Water and Environment Sector Performance Report, Uganda.
- Nachbar, J. (2009) Basic Properties of the Euclidean Norm. In, J. Nachbar, ed., *Economics* 511.
- Newman, P. (2001) Sustainable urban water systems in rich and poor cities--steps towards a new approach. *Water science and technology: a journal of the International Association on Water Pollution Research*, **43**(4), 93.
- Nicklow, J., Reed, P., Savic, D., Dessalegne, T., Harrell, L., Chan-Hilton, A., Karamouz, M., Minsker, B., Ostfeld, A., and Singh, A. (2010) State of the art for genetic algorithms and beyond in water resources planning and management. *Journal of Water Resources Planning and Management*, **136**, 412.
- Nilchiani, R. (2005) *Measuring Space Systems Flexibility: A Comprehensive Six-element Framework*, Massachusetts Institute of Technology, Cambridge, MA,.

- Nilchiani, R., and Hastings, D. E. (2007) Measuring the value of flexibility in space systems: A six-element framework. *Systems Engineering*, **10**(1), 26-44.
- NWSC (2011) Uganda National Water and Sewerage Corporation Annual Report, Kampala, Uganda.
- Olewnik, A., and Lewis, K. (2006) A decision support framework for flexible system design. *Journal of Engineering Design*, **17**(1), 75-97.
- Ostfeld, A. (2004) Reliability analysis of water distribution systems. *Journal of Hydroinformatics, IWA*, **6**(4), 281-294.
- Parsons, S., and Wooldridge, M. (2002) Game theory and decision theory in multi-agent systems. *Autonomous Agents and Multi-Agent Systems*, **5**(3), 243-254.
- Peng, S., and Zhao, X. (2009) A Review of Uncertainty Methods Employed in Water Quality Modeling. 32-35.
- Popov, A. (2005) Genetic Algorithms for optimization. *User Manual, Hamburg, Germany*.
- Prasad, T. D. (2004) Multiobjective genetic algorithms for design of water distribution networks. *Journal of Water Resources Planning and Management*, **130**, 73.
- PSGS (2010) *Integrated Urban Water Management for Arua, Uganda, World Bank*.
- Raad, D. N., Sinske, A. N., and van Vuuren, J. H. (2010) Comparison of four reliability surrogate measures for water distribution systems design. *Water Resources Research*, **46**(5), W05524.
- Ramirez, N. (2002) *Valuing flexibility in infrastructure developments: the Bogota water supply expansion plan*, Massachusetts Institute of Technology.
- Ross, A. M., Rhodes, D. H., and Hastings, D. E. (2008) Defining changeability: Reconciling flexibility, adaptability, scalability, modifiability, and robustness for maintaining system lifecycle value. *Systems Engineering*, **11**(3), 246-262.
- Safe, M., Carballido, J., Ponzoni, I., and Brignole, N. (2004) On stopping criteria for genetic algorithms. *Advances in Artificial Intelligence, SBIA 2004*, 405-413.
- Saleh, J. H., Hastings, D. E., and Newman, D. J. (2001) Extracting the essence of flexibility in system design. 59-72.

- Saleh, J. H., Hastings, D. E., and Newman, D. J. (2003) Flexibility in system design and implications for aerospace systems. *Acta Astronautica*, **53**(12), 927-944.
- Savic, D. (2002) Single-objective vs. Multiobjective Optimisation for Integrated Decision Support. *In: Integrated Assessment and Decision Support*, Rizzoli, A.E. and A.J. Jakeman (eds.), *Proceedings of the First Biennial Meeting of International Environmental Modelling and software Society*, Lugano, Switzerland, 7-12.
- Savic, D. A. (2005) Coping With Risk And Uncertainty In Urban Water Infrastructure Rehabilitation Planning School of Engineering, Computer Science and Mathematics, University of Exeter.
- Savic, D., Walters, G., and Schwab, M. (1997) Multiobjective genetic algorithms for pump scheduling in water supply. *Lecture Notes in Computer Science*, **1305**, 227-236.
- Schoemaker, P. J. H. (1991). "When and how to use scenario planning: A heuristic approach with illustration." *Journal of forecasting* **10**(6): 549-564.
- Scholtes, S. (2007) *Flexibility: The Secret to Transforming Risks into Opportunities*. [Online] <http://www.eng.cam.ac.uk/~ss248/publications/BusinessDigest.pdf> [Access date: Nov 12]
- Schulz, A. P., Fricke, E., and Igenbergs, E. (2000) Enabling Changes in Systems throughout the Entire Life-Cycle – Key to Success ? 10th annual INCOSE conference, Minneapolis, USA.
- Segrave, A. (2007) Report on trends in the Netherlands. TECHNEAU.
- Shah, N. B., Viscito, L., Wilds, J., Ross, A. M., and Hastings, D. (2008) Quantifying flexibility for architecting changeable systems.
- Shannon, C. E. (1948) A mathematical theory of communication. Technical journal, AT & T Bell Labs. October.
- Shibu A. and Janga Reddy M. (2011). Uncertainty Analysis of Water Distribution Networks by Fuzzy - Cross Entropy Approach, *World Academy of Science, Engineering and Technology*, **59**, 724-731.
- Siedlecki, W., and Sklansky, J. (1993) Constrained genetic optimization via dynamic reward-penalty balancing and its use in pattern recognition. *Handbook of pattern recognition & computer vision*, 108-123.
- Silver, M. R., and de Weck, O. L. (2007) Time-expanded decision networks: A framework for designing evolvable complex systems. *System Engineering-New York*, **10**(2), 167.

- Simpson, A. R., Dandy, G. C., and Murphy, L. J. (1994) Genetic algorithms compared to other techniques for pipe optimization. *Journal of Water Resources Planning and Management*, **120**(4), 423-443.
- Singh, K., Malik, D., and Sharma, N. (2011) Evolving limitations in K-means algorithm in data mining and their removal. *International Journal of Computational Engineering & Management*, **12**, 105-109.
- Srinivas, M., and Patnaik, L. M. (1994) Adaptive probabilities of crossover and mutation in genetic algorithms. *Systems, Man and Cybernetics, IEEE Transactions on*, **24**(4), 656-667.
- Su, Y. C., Duan, N., and Lansey, K. E. (1987) Reliability- Based Optimization Model for Water Distribution Systems. *Journal of Hydraulic Engineering*, **113**, 1539.
- Suh, E. S. (2005) *Flexible Product Platforms*, Massachusetts Institute of Technology, Engineering Systems Division Cambridge, MA.
- Swamee, P. K., and Sharma, A. K. (2008) *Design of water supply pipe networks*, Wiley-Interscience.
- Tanyimboh, T. T., and Templeman, A. B. (1993) Maximum entropy flows for single-source networks. *Engineering Optimization*, **22**(1), 49-63.
- Tanyimboh, T. T., and Templeman, A. B. (1993) Optimum design of flexible water distribution networks. *Civil Engineering Systems*, **10**(3), 243-258.
- Tanyimboh, T. T., and Templeman, A. B. (2000) A quantified assessment of the relationship between the reliability and entropy of water distribution systems. *Engineering Optimization*, **33**(2), 179-199.
- Thomure, T. (2009). Scenario Planning: Making Strategic Decisions in Uncertain Times. 54th Annual New Mexico Water Conference, Water Planning in a Time of Uncertainty.
- Todini, E. (2000) Looped water distribution networks design using a resilience index based heuristic approach. *Urban water*, **2**(2), 115-122.
- Todini, E. (2000) Looped water distribution networks design using a resilience index based heuristic approach. *Urban water*, **2**(2), 115-122.
- Tolson, B. A., and Maier, H. R. (2004) Genetic algorithms for reliability-based optimization of water distribution systems. *Journal of Water Resources Planning and Management*, **130**, 63.



- Tolson, B. A., and Maier, H. R. (2004) Genetic algorithms for reliability-based optimization of water distribution systems. *Journal of Water Resources Planning and Management*, **130**, 63.
- Trifunovic, N. (2012) *Pattern Recognition for Assessment of Water Distribution Network*, UNESCO-IHE Institute for Water Education, Delft, Netherland.
- Troffaes, M. (2007) Decision making under uncertainty using imprecise probabilities. *International Journal of Approximate Reasoning*, **45**(1), 17-29.
- Tsegaye, S., and Vairavamoorthy, K. (2011) *Water Demand management in the City of the Future: Agent Based Modelling for Demand Side Water Management Strategies (Chapter 5)*, Water, Engineering and Development Center, Loughborough University, UK.
- Tsegaye, S., Eckart, J., and Vairavamoorthy, K. (2011) Decision Support Framework for Design of Flexible Urban Water Distribution Systems. *The Future of Urban Water: Solutions for Livable and Resilient Cities* Paris.
- Tsegaye, S., Eckart, J., and Vairavamoorthy, K. (2012) Urban Water Management in Cities of the Future: Emerging Areas in Developing Countries. *On the Water Front*, 42.
- UBOS. (2011). "Mid-Year Projected Population for Town Councils ", Uganda Bureau of Statistics (UBOS), Kampala, Uganda.
- Upton, D. M. (1994) The management of manufacturing flexibility. *California management review*, **36**, 72-72.
- Vairavamoorthy, K., and Ali, M. (2000) Optimal design of water distribution systems using genetic algorithms. *Computer-Aided Civil and Infrastructure Engineering*, **15**(5), 374-382.
- Vairavamoorthy, K., and Tsegaye, S. (2011) *Water Distribution Systems: Design of Water Distribution Systems (Chapter 7)*, ICE Publishing, Thomas Telford, UK.
- Vairavamoorthy, K., Ghebremichael, K., Eckart, J., Tsegaye, S., and Khatri, K. (2012) Chapter 2: An Integrated Perspective for Urban Water, Management The Future of Water in African Cities: Why Waste Water? . World Bank.
- Valerie, N. (2008) *New Approach in Decentralized Water Infrastructure*. Coalition of Alternative Wastewater Treatment.

- Wagner, J. M., Shamir, U., and Marks, D. H. (1988) Water distribution reliability: analytical methods. *Journal of Water Resources Planning and Management*, **114**(3).
- Walski, T. M., Brill, E. D., and Gessler, J. (1987) Battel of the network models. *Journal of Water Resource Planning and Management*, **113**(2).
- Walski, T. M., Chase, D. V., Savic, D. A., Grayman, W., Beckwith, S., and Koelle, E. (2003) *Advanced Water Distribution Modeling and Management*. Haestad Press, Waterbury CT.
- Wang, X., Chen, R., Zhang, Q., and Li, K. (2008) Optimized plan of centralized and decentralized wastewater reuse systems for housing development in the urban area of Xi'an, China. *Water science and technology*, **58**(5), 969.
- Watanatada, T. (1973) Least-cost design of water distribution systems. *Journal of the Hydraulics Division*, **99**(9), 1497-1513
- Weber, B., Cornel, P., and Wagner, M. (2007) Semi-centralized supply and treatment systems for (fast growing) urban areas. **55**(1-2), 349-356.
- Webster, M., Jacobsen, M., and Vairavamoorthy, K. (2012) The Future of Water in African Cities: Why Waste Water?
- Whitley, D. (1989) The GENITOR algorithm and selection pressure: Why rank-based allocation of reproductive trials is best. *Proceedings of the third international conference on Genetic algorithms*, 116-121.
- Xu, C., and Goulter, I. C. (1999) Reliability-based optimal design of water distribution networks. *Journal of Water Resources Planning and Management*, **125**, 352.
- Yassine, A. A., and Falkenburg, D. R. (1999) A Framework for Design Process Specifications Management. *Journal of Engineering Design*, **10**(3).
- Zecchin, A. C., Maier, H. R., Simpson, A. R., Leonard, M., and Nixon, J. B. (2007) Ant colony optimization applied to water distribution system design: comparative study of five algorithms. *Journal of Water Resources Planning and Management*, **133**, 87.
- Zecchin, A. C., Simpson, A. R., Maier, H. R., and Nixon, J. B. (2005) Parametric study for an ant algorithm applied to water distribution system optimization. *IEEE transactions on evolutionary computation*, **9**(2), 175-191.
- Zhao, T., and Tseng, C. L. (2003) Valuing Flexibility in Infrastructure Expansion. *Journal of Infrastructure Systems*, **9**(3), 89-97.



## Appendices

## Appendix 1 Water Source Grouping

Table A.1 Matrix for water source centers determination

	Source	Relative Distance (m)															Group	
		1	2	3	4	5	6	7	8	9	10	11	12	13	14	15		16
Groundwater	1	0	1485	3926	3926	4119	5091	5419	5284	7591	6316	4149	3986	6792	4203	2372	1006	1
	2		0	2442	2442	2683	3606	3937	3833	6172	5284	3578	3612	5708	3276	2163	2040	1
	3			0	212	960	1172	1544	1530	3894	4119	3795	4149	4360	2885	3502	4327	2
	4				0	750	1172	1500	1657	4002	4327	3986	4329	4562	3089	3628	4373	2
	5					0	1358	1477	2148	4360	5040	4708	5029	5248	3833	4200	4708	2
	6						0	450	960	3004	4149	4522	4952	4248	3502	4555	5493	3
	7							0	1290	3015	4500	4970	5402	4562	3946	4986	5867	3
	8 (forest area)								0	2372	3210	3912	4391	3290	2854	4298	5515	8
	9									0	3314	5303	5842	3004	4327	6259	7710	4
	10										0	2624	3121	541	2121	4224	6004	5
	11											0	541	3164	1061	1806	3600	6
	12												0	3662	1566	1616	3331	6
Surface water	13												0	2620	4743	6512	5	
	14													0	2148	3894	6	
	15														0	1806	7	
	16															0	1	

## **Appendix 2 Investment Cost Comparison**

In addition to the cost comparison of WDS presented in Chapter 7, this subsection compares other investment costs for centralized and clustered water supply systems (WSS) for Arua town. These include the cost of collection, storage and treatment for both centralized and clustered WSS.

### **A2.1 Water Collection**

In respect to water collection, Arua town is located in water scarce area and one of the alternative sources for centralized system under consideration is 22km away from the town at Olewa, which is also the location for a proposed hydropower plant along the River Enyau.

## Appendix 2 (continued)

According to a hydrological study undertaken at this location (Environmental Management Associates, 2002) the estimated average flow is 59,184 m<sup>3</sup>/d with an estimated range of 10,900 to 198,700 m<sup>3</sup>/d. This source can provide sufficient quantity to Aura to meet the 2032 demand but it requires huge collection effort as it is located 200m below the elevation of the Town. However the proposed clustered WSS development in this study exploits the potential local water sources in the area. So in addition to the water distribution pipes, investment cost for water collection pipe for both WSS is considered for comparison. The collection pipe cost is calculated for each WSS in Table A.2 and Table A.3 and summarized in Table A.4.

Table A.2 Water collection for centralized WSS (real cost)

Source	Flow (m <sup>3</sup> /d)	Distance to WTP (m)	Diameter (mm)	Pipe cost (US\$)	Pipe laying cost (US\$)	Total (US\$)
Olewa	11457	22000	406.4	1980000	440000	2420000
Enyau	5760	1209	406.4	108840	24187	133027

Table A.3 Water collection cost for clustered WSS (real cost)

Source center	Source location		Reservoir location		Distance to WTP	Pipe Dia. (mm)	Head loss m/km	Total loss	Pipe cost (US\$)	pipe laying (US\$)	Total (US\$)
	X2 (m)	Y2 (m)	X2 (m)	Y2 (m)							
C9	2700	3000	3900	2850	1209	508	0.45	5.4	205588	30233	235821.0
C8	5400	2850	5400	3158	308	254	0.40	1.2	9856	2156	12012.0
C4	6150	600	5700	900	541	304.8	0.40	2.2	27042	5408	32450.0
C5	3110	510	2850	2100	1611	203.2	0.50	8.1	37058	11278	48336.3
C6	2062	3108	1350	2250	1115	254	0.45	5.0	35681	7805	43486.5
C7	1650	4950	1650	4800	150	254	0.40	0.6	4800	1050	5850.0
C1	1992	6772	2850	7500	1126	203.2	0.59	6.6	25888	7879	33766.4
C2	5461	4650	5400	5100	454	254	0.45	2.0	14534	3179	17713.0
C3	6181	3600	6750	3600	569	254	0.35	2.0	18195	3980	22174.6

## Appendix 2 (continued)

Table A.4 Water collection cost comparison

Stage	Year	Area	Cost (US\$)		NPV(US\$)	
			Centralized	Clustered	Centralized	Clustered
0	2012	C9	2553027	235821	2553027	235821
1	2017	C8	-	12012	-	10362
2	2022	C4, C5, C6	-	124273	-	92471
3	2027	C7, C1	-	39616	-	25428
4	2032	C2, C3	-	39888	-	22085
<b>Total</b>			<b>2553027</b>	<b>451610</b>	<b>2553027</b>	<b>386166</b>

The comparison in NPV shows that the clustered system offers 85% cost saving than centralized system. This is because the clustered system water sources are located within the small clusters closer to the collection unit, thus the cost of collection pipes are relatively small whereas the centralized system required collection of water from Olewa River which is 22km and makes this option more expensive in terms of both capital and operational expenditure.

### **A2.2 Elevated Reservoirs**

The proposed WSS for Arua Town has one reservoir in case of centralized system for the whole area and nine reservoirs in case of clustered WSS. Thus the determination of the cost of reservoirs is essential for comparison between central and clustered approach. Relevant data for cost of construction concrete reservoirs is taken from NWSC (2011). The cost proportion involves US \$2469 for 25m<sup>3</sup>, US \$3137 for 39m<sup>3</sup> and US \$331305 for 50m<sup>3</sup> reservoir sizes.

## Appendix 2 (continued)

Based on the proportion, the cost of construction of elevated concrete reservoirs for the proposed systems is calculated and shown in Table A.5.

Table A.5 Construction cost of reservoirs

Stage	Year	Area	Cost (US\$)		NPV(US\$)	
			Centralized	Clustered	Centralized	Clustered
0	2012	C9	116183	84742	2553027	667068
1	2017	C8	-	26343	-	292239
2	2022	C4, C5, C6	60026	83864	38529	777619
3	2027	C7, C1	-	49323	-	418344
4	2032	C2, C3	-	52295	-	373351
<b>Total</b>			<b>176209</b>	<b>296567</b>	<b>154712</b>	<b>2528620</b>

The above table shows that the cost of construction of large reservoir for centralized WSS is 49% less expensive than constructing many small reservoirs for clustered WSS. That is because as the unit enlarged from smaller to larger size, the scale generally results in lower construction cost per unit capacity. Thus large centralized systems generate huge benefit from economy of scale.

### A2.3 Water Treatment Plant (WTP)

The investment cost of water treatment plant (WTP) varies with the scale of the units. According to (Webster et al., 2012) the specific investment and operation cost decrease with increasing size of the treatment units. Centralized and large WTP have the lowest unit investment cost, and are favored by the economy of scale.

## Appendix 2 (continued)

However the clustered system benefits from small scale low cost treatment units such as Slow Sand Filters (SSF). SSF is a reliable water purification technology in developing countries because of its performance, low construction cost, low operation and maintenance requirement and no purchase of chemicals. In this subsection, the conventional WTP (coagulation, sedimentation, filtration and disinfection) and SSF treatment technologies are considered in the cost comparison. First conventional WTP is proposed for both centralized and clustered system and cost comparison is performed. Second a conventional water treatment unit for the centralized system, and a SSF for the clustered system is proposed and independent comparison is performed.

- i) Conventional WTP for Both Centralized and Clustered: There is lack of data to calculate the cost of WTP for different scales in Uganda. Although the unit costs might differ considerably for different countries, the casual correlation between size and specific cost will be alike (Webster et al., 2012). Thus the correlation for different scales conventional treatment units is taken from US Environmental Protection Agency survey data (1999) and scaled using local treatment plant cost data from Uganda (Webster et al. 2012). Figure A.1 shows correlated unit cost for construction of conventional WTP in Uganda.

## Appendix 2 (continued)

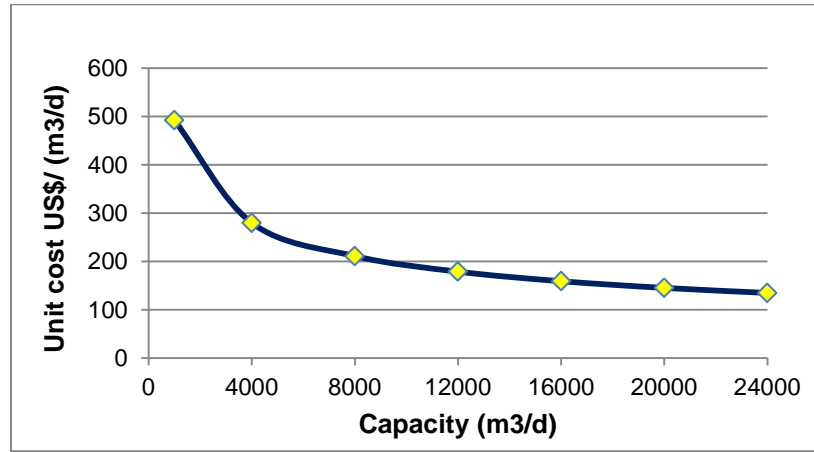

Figure A.1 Unit construction cost of conventional filter WTPs in Uganda

To avoid the problem associated with expanding the centralized WTP, a two stage development is proposed. The first stage considers demand for year 2012 and the second stage for year 2027. Unlike the centralized systems, the cluster systems are small and independent such that the design could follow the stages proposed by the population growth. Thus the centralized WSS will have one treatment plant constructed in two stages and the clustered WSS will have nine treatment units constructed in five stages. The total construction cost is calculated using the unit cost for respective treatment capacity. Table A.6 shows the total investment cost for conventional WTP for Arua centralized and clusters systems.



## Appendix 2 (continued)

Table A.6 Construction cost of conventional WTP

Stage	Year	Area	Demand (m <sup>3</sup> /d)	Conventional WTP (real cost US\$)		Conventional WTP (NPV in US\$)	
				Centralized	Centralized	Centralized	Clustered
0	2012	C9	7694	2232676	1650289	2232676	1650289
1	2017	C8	1166	-	538916	-	464874
2	2022	C4, C5, C6	3949	-	1709509	-	1272035
3	2027	C7, C1	2100	1186081	1011741	761300	649398
4	2032	C2, C3	2308	-	1070069	-	59247
<b>Total</b>			<b>17217</b>	<b>3418757</b>	<b>5980524</b>	<b>2993976</b>	<b>4629067</b>

According to the result depicted Table A.6, the investment cost (in NPV term) of WTP for clustered water system is 55% higher than the centralized WTP. This is because that the centralized large treatment plants have lowest unit investment cost than small clustered treatment systems. However the smaller units could benefit from other low-cost small treatment units discussed below.

- ii) SSF for Clustered and Conventional WTP for Centralized WSS: A small and autonomous clustered system could benefit from small scalable low cost treatment units. So in addition to the conventional WTP for both centralized and clustered system this study proposes comparison based on Slow Sand filtration (SSF) for clustered WSS. SSF is a simple and reliable filtration technology for low turbidity (<20TU) water sources. It has an excellent removal capacity for pathogenic organisms. SSF is especially appropriate for small scale treatment and requires less amount of cost for construction.

## Appendix 2 (continued)

SSF provides a low energy treatment process. SSF requires large amount of land because of the slow filtration process however it's a great adaptability in components and provides a low maintenance system that doesn't need constant attention for operation. It can also be manufactured using local skills and materials. In order to calculate the cost of SSF for Arua Town, similar approach as conventional WTP is followed. To the best of our knowledge SSF has not been built in Uganda. Thus investment cost data from the other less-developed country, Federated States of Micronesia (FSM) is used in the calculation of the SSF investment expense (Khosrowpanah and Heitz, 2003). A casual correlation between size and specific cost is done using the required treatment unit. Figure A.2 shows the unit cost for construction of SSF in Arua.

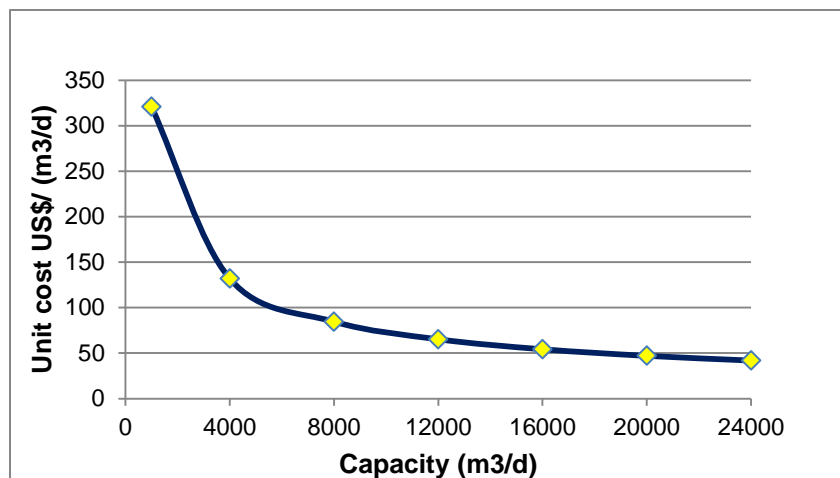

Figure A.2 Unit construction cost of SSF

## Appendix 2 (continued)

The construction cost of SSF for all clusters is calculated based on the unit cost shown above and tabulated in Table A.7 (column eight). Whereas the same cost for conventional WTP calculated in Table A.6 is used for the centralized system. This is because SSF requires huge amount of land and is not reliable for large scale treatment systems.

Table A.7 Conventional WTP for centralize and SSF for clustered WSS

Stage	Year	Area	Flow (m3/d)	Real cost (US\$)		NPV (US\$)	
				Conventional centralized	SSF for Clustered	Conventional centralized	SSF for Clustered
0	2012	C9	7694	2232676	667068	2232676	667068
1	2017	C8	1166	-	338785	-	292239
2	2022	C4, C5, C6	3949	-	1045056	-	777619
3	2027	C7, C1	2100	1186081	651766	761300	418344
4	2032	C2, C3	2308	-	674313	-	373351
<b>Total</b>			<b>17217</b>	<b>3418757</b>	<b>3376987</b>	<b>2993976</b>	<b>2528620</b>

The investment cost of SSF for clustered water system is 16% less expensive than the centralized WTP. This is because the clustered WSS benefits from the economic scale of low cost treatment units of SSF.

## Appendix 3 Operation and Maintenance Cost Comparison

### A3.1 Conventional WTP for Both Centralized and Clustered

In calculation of the annual operation cost of conventional WTP different cost expenses are considered. One of the largest cost items for conventional water treatment is chemicals, which typically include various coagulants, disinfectants, and pH adjusters (Dearmont, McCarl, and Tolman 1998). Others include cost related to electricity, administration, labor and maintenance. A 20 mg/L FeCl<sub>3</sub> and 3 mg/L Cl<sub>2</sub> for 100,000m<sup>3</sup>/d flow, a yearly 1% total construction cost for maintenance and an administration cost of 50% of staff cost is considered for calculation of operation cost. The summary of the cost comparison for conventional WTP for both centralized and clustered approach is shown in Table A.8.

Table A.8 Cost for operation and maintenance of conventional WTP

Year	Area/ clusters	Flow (m <sup>3</sup> /d)	Annual cost (real cost in US\$)		O&M NPV in US\$	
			Centralized	Clustered	Centralized	Clustered
2012 to 2017	C9	7694	1164527	1086246	1098637	1024786
2017 to 2022	C9, C8	8860	1721091	1388149	1400627	1129679
2022 to 2027	C9, C8, C4, C5, C6	12809	2197825	2336065	1542858	1639901
2027 to 2032	C9, C8, C4, C5, C6, C7, C1	14909	2690671	2917805	1629323	1766863
2032	C9, C8, C4, C5, C6, C7, C1, C2, C3	17217	629849	703870	348732	389716
<b>Total</b>			<b>8403963</b>	<b>8432135</b>	<b>6020177</b>	<b>5950944</b>

### **Appendix 3 (continued)**

Table A.8 shows that the operation cost of for clustered system is 1.2% less expensive than centralized once. The smaller but many conventional WTPs may not offer much O&M benefit because of the trade-off between increase in the unit cost of chemical, and electric costs and reduced cost of management and maintenance requirement for staged development.

#### ***A3.2 SSF for Clustered and Conventional WTP for Centralized WSS***

SSF is a reliable water purification technology for small community. It requires low operation and maintenance and no purchase of chemicals. Some of the operation and maintenance components involve: removal of floating material, slow drain of the water below sand media level, scrape the top 1-3 cm of sand, sand replacement (Federated States of Micronesia). Thus one of the largest cost items for SSF operation and maintenance is manpower. Staffing requirements depend upon the size of a facility, the treatment processes that it employs. Operating labor for SSF facilities of capacity 940- 7570 m<sup>3</sup>/d requires 1-2hr/day plus scraping (Environmental Health program 2003). It is also required to replace the sand in 2 years. In this calculation 3 people for 2 days of monthly sand scraping and 5 people for 2 days of sand replacement of 100m<sup>2</sup> surface are SSF is considered and proportioned with the treatment unit capacity required for each clusters. The total annual operation and maintenance cost of SSF for each clusters is summarized in Table A.9.

### Appendix 3 (continued)

Table A.9 Annual running cost for SSF

Cluster	DQ (m3/d)	Annual Cost US\$					Yearly Total US\$	Yearly total (US\$)	Sum (real cost US\$)
		Area (m2)	Sand Scraping	Sand replac.	Staff (1@1000\$)	Admin. (50% of staff cost)			
C9	7694	70	4029	4756	1000	500	123422	123422	123422
C8	1166	11	610	721	1000	500	33970	33970	157392
C4	1910	17	1000	1181	1000	500	44175	108113	265505
C5	752	7	394	465	1000	500	28299		
C6	1287	12	674	796	1000	500	35639		
C7	1166	11	611	721	1000	500	33982		
C1	934	8	489	577	1000	500	30797		
C2	1272	12	666	786	1000	500	35426	67620	397904
C3	1036	9	542	640	1000	500	32194		

Table A.10 Annual running cost comparison (conventional Vs. SSF)

Year	Area/clusters	Flow (m3/d)	Operation cost (NPV in US\$)	
			Conventional	SSF
2012 to 2017	C9	7694	1098637	582193
2017 to 2022	C9, C8	8860	1400627	640429
2022 to 2027	C9, C8, C4, C5, C6	12809	1542858	931913
2027 to 2032	C9, C8, C4, C5, C6, C7, C1	14909	1629323	1000009
2032	C9, C8, C4, C5, C6, C7, C1, C2, C3	17217	348732	220310
<b>Total</b>			<b>6020177</b>	<b>3374853</b>

The result in Table A.10 depicts that the operation cost of SSF is 44% less expensive than the centralized conventional WTP. In addition to many of the new values being discovered from clustering, such as the ability to reuse recycle, adaptability etc decentralization offers cost saving from investment and operation cost of small scale low-cost treatment units like SSF.

## Appendix 3 (continued)

### A3.3 Water Pumping Costs

Most of the energy consumed in drinking water supply is associated with pumping water. Since the WDS in Arua Town is a gravity system, the energy cost calculation in this section considers pumping used to abstract (surface and groundwater) and deliver raw water to the treatment plant, and to deliver clean water to elevated reservoirs. Equation A3.1 is used to determine the required energy for collection and distribution, and local unit cost is used to determine related cost.

$$P = \frac{\rho ghQ}{\mu} \quad \text{A3.1}$$

where P is the power in Watt,  $\rho$  is density of liquid in  $\text{Kg/m}^3$ , g is gravity ( $9.81\text{m/s}^2$ ), h is head in meter of water, Q is flow in  $\text{m}^3/\text{s}$ , and  $\mu$  is pump efficiency.

Arua municipality has proposed centralized WSS that involves raw water collection from both Enyau and Olewa River. Olewa River is located at a distance of 22Km and elevation of 200m below Arua Town and this involves huge pumping cost. In contrary, the clustered WSS proposed in this study explore potential local water sources and reduce the effort to collect and deliver to the consumers. In this section the pumping cost for the proposed centralized and clustered WSS is calculated.

### Appendix 3 (continued)

A pump efficiency of 70% and an average local energy cost of 0.17\$/Kwh (umeme LTD, NWSC 2012) is used for calculation of pumping cost. A summary of the output is shown in this section (see Table A.11).

Table A.11 Annual pumping cost for centralized and clustered WSS

Year	Source centers/clusters	Pumping Cost (NPV in US\$)	
		Centralized WSS	Clustered WSS
2012 to 2017	C9	148051	113388
2017 to 2022	C9, C8	167912	121200
2022 to 2027	C9, C8, C4, C5, C6	278026	137215
2027 to 2032	C9, C8, C4, C5, C6, C7, C1	312744	137130
2032	C9, C8, C4, C5, C6, C7, C1, C2, C3	74462	35711
<b>Total</b>		<b>981195</b>	<b>544644</b>

The result shows that the pumping cost for centralized WSS is 44% higher than the clustered WSS. This is because the centralized WSS require pumping and distributing water long distance than the cluster WSS which exploit the local water sources and reduce the effort required to transport water.



## Appendix 4 Overall Cost Comparison

Recently attention has been paid to the economic feasibility of decentralized WSS (Chen and Wang, 2009; Bieker et al., 2010). Therefore in this section the cost comparisons between centralized and decentralized systems for Arua, Town is presented. The cost comparison involves investment cost (collection and distribution pipes, elevated reservoirs, water treatment plants), and operation and maintenance (running water treatment plants, pumping energy cost for water collection and distribution). These cost components are calculated in the previous subsection and the comparison is done in two different categories such as (i) Both the centralized and clusters WSS involving conventional WTP (ii) The centralized WSS involving conventional WTP and the clustered WSS involves Slow Sand Filter system.

In this case study the Net Present Value (NPV) of system components, and operation and maintenance for a period of 20 years is calculated and Equivalent Annual Cost (EAC) is used for the comparison of centralized and decentralized system. In financial term EAC is the cost per year of owning and operating an asset. The EAC is determined by dividing the NPV by Annuity factor ( $A_t$ ).  $A_t$  is termed as a fixed payment over a specific period of time. Equation A4.1, A4.2 and A4.3 show the formulas for calculating NPV,  $A_t$  and EAC for this case-study.

## Appendix 4 (continued)

$$NPV = \sum \frac{R_{t_n}}{(1+r)^{t_n}} \quad A4.1$$

$$A_t = \frac{(1+r)^t - 1}{r * (1+r)^t} \quad A4.2$$

$$EAC = \frac{NPV}{A_t} \quad A4.3$$

where  $R_{t_n}$  is the net cash flow (initial investment or running costs) in US\$ at any year,  $t_n$  is the time of cash flow in years,  $r$  is the annual interest rate (3% is used),  $t$  is the operating life time in years,  $A_t$  is the annuity factor.

### ***A4.1 Both Centralized and Clusters WSS Involving Conventional WTP***

In this case a conventional WTP for both centralized and clustered systems is considered in the cost calculation. In addition to the treatment units, other cost components considered include investment costs for collection and distribution pipes, reservoirs, pumping energy cost for water collection and distribution and water treatment, and operation and maintenance. A 20 year design period is and an annual interest rate of 3% is used. Table A.12 and Table A.13 summarized the cost components in NPV for both centralized and clustered systems respectively.

## Appendix 4 (continued)

Table A.12 Cost component for centralized WSS with conventional WTP

Year	Clusters	WSS cost components (US\$)						NPV
		Distribu- tion pipe	Collec- tion pipe	Reser- voir	Pump- ing	WTP	WTP O&M	
0	C9	848025	2553027	116183	31386	2232676	232905	6014203
1		0	0	0	30472	0	226122	256594
2		0	0	0	29584	0	219536	249120
3		0	0	0	28723	0	213141	241864
4		0	0	0	27886	0	206933	234819
5	C8	218736	0	0	35596	0	296926	551258
6		0	0	0	34560	0	288277	322837
7		0	0	0	33553	0	279881	313434
8		0	0	0	32576	0	271729	304305
9		0	0	0	31627	0	263815	295441
10	C4+C5+C6	346126	0	0	58940	0	327078	732144
11		0	0	0	57223	0	317551	374775
12		0	0	0	55557	0	308302	363859
13		0	0	0	53939	0	299322	353261
14		0	0	0	52368	0	290604	342972
15	C7+C1	263218	0	38529	66300	761300	345408	1474755
16		0	0	0	64369	0	335347	399716
17		0	0	0	62494	0	325580	388074
18		0	0	0	60674	0	316097	376771
19		0	0	0	58907	0	306890	365797
20	C2+C3	158880	0	0	74462	0	348732	582074
<b>Total</b>		<b>1834985</b>	<b>2553027</b>	<b>154712</b>	<b>981195</b>	<b>2993976</b>	<b>6020177</b>	<b>14538073</b>

## Appendix 4 (continued)

Table A.13 Cost components for clustered WSS with conventional WTP

Year	Clusters	WSS cost components (US\$)						NPV
		Distribu- tion pipe	Collec- tion pipe	Reser- voir	Pump- ing	WTP	WTP O&M	
0	C9	603235	235821	84742	24038	1650289	217249	2815374
1		0	0	0	23338	0	210922	234259
2		0	0	0	22658	0	204778	227436
3		0	0	0	21998	0	198814	220812
4		0	0	0	21357	0	193023	214380
5	C8	74870	10362	22724	25694	464874	239486	838009
6		0	0	0	24945	0	232511	257456
7		0	0	0	24219	0	225738	249957
8		0	0	0	23513	0	219164	242677
9		0	0	0	22829	0	212780	235609
10	C4+C5+C6	265225	92471	62402	29089	1272035	347650	2068872
11		0	0	0	28242	0	337525	365766
12		0	0	0	27419	0	327694	355113
13		0	0	0	26620	0	318149	344770
14		0	0	0	25845	0	308883	334728
15	C7+C1	227534	25428	31659	29071	649398	374566	1337655
16		0	0	0	28224	0	363656	391880
17		0	0	0	27402	0	353064	380466
18		0	0	0	26604	0	342781	369385
19		0	0	0	25829	0	332797	358626
20	C2+C3	103385	22085	28954	35711	592471	389716	1172322
<b>Total</b>		<b>1274249</b>	<b>386166</b>	<b>230482</b>	<b>544644</b>	<b>4629067</b>	<b>5950944</b>	<b>13015552</b>

## Appendix 4 (continued)

Figure A.3 shows the comparison of NPV cost components for centralized and cluster system.

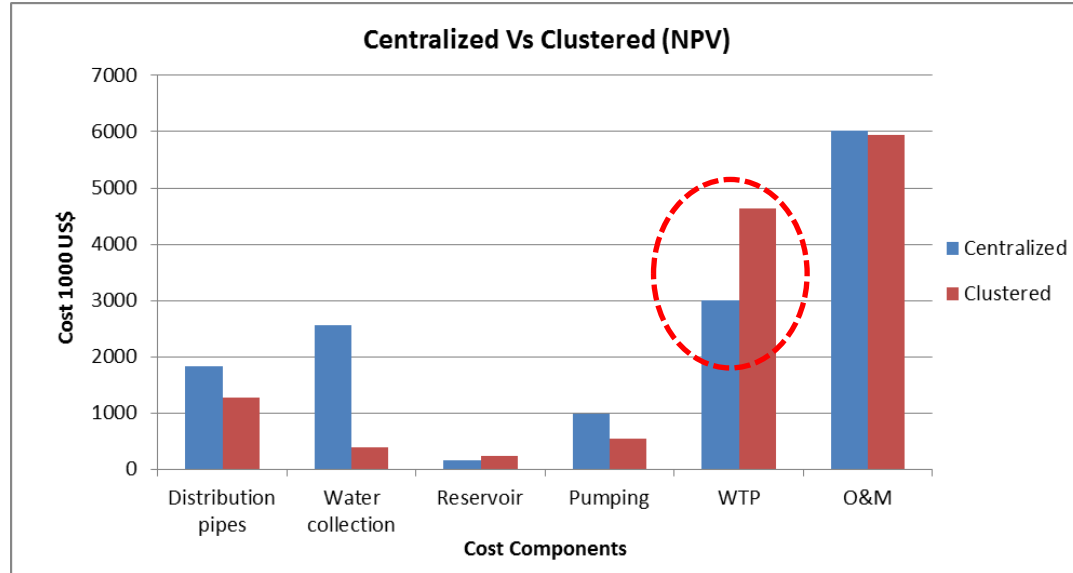

Figure A.3 Cost comparison between centralized and clustered systems (with conventional WTP)

The cost calculation for the centralized WSS is shown below:

$$NPV = \sum \frac{R_{t_n}}{(1+r)^{t_n}} = 14538073 \text{ US\$}$$

$$A_t = \frac{(1+r)^t - 1}{r * (1+r)^t} = \frac{(1+0.03)^{20} - 1}{0.03 * (1+0.03)^{20}} = 15$$

$$EAC = \frac{NPV}{A_t} = 977187 \text{ US\$}$$

The cost calculation for clustered WSS is shown below:

$$NPV = 13015552 \text{ US\$}$$

$$EAC = \frac{NPV}{A_t} = 874850 \text{ US\$}$$

## **Appendix 4 (continued)**

The result shows that the total cost of WTP (sum of 9 small units) is 55% higher than the conventional WTP for centralized system. This is because the large WTP is favored by the economy of scale. However the overall comparison of EAC for this case-study depicts that clustered WSS (US \$874,850 per year) is cheaper than the centralized WSS (US \$977,187 per year). This means the clustered WSS offers an annual cost saving of 10% every year than centralized WSS. In addition cluster WSS could offer more benefit from the implement of small and low cost treatment units. Thus next subsection explores the advantage of clusters using small scale cheap treatment systems- SSF.

### ***A4.2 Conventional WTP for Centralized and SSF for Clusters***

In this case a conventional WTP for centralized and SSF for clustered systems is considered in the cost calculation. Table A.14 summarizes the calculated cost components from clustered WSS in NPV term. Figure A.4 shows the comparison of each NPV cost components for centralized and cluster system.

## Appendix 4 (continued)

Table A.14 Cost components for clustered WSS with SSF treatment

Year	Clusters	WSS cost components (US\$)						NPV
		Distribu- tion pipe	Collec- tion pipe	Reser- voir	Pump- ing	WTP	WTP O&M	
0	C9	603235	235821	84742	24038	667068	123422	1738326
1		0	0	0	23338	0	119827	143165
2		0	0	0	22658	0	116337	138995
3		0	0	0	21998	0	112948	134946
4		0	0	0	21357	0	109659	131016
5	C8	74870	10362	22724	25694	292239	135768	561656
6		0	0	0	24945	0	131813	156758
7		0	0	0	24219	0	127974	152193
8		0	0	0	23513	0	124247	147760
9		0	0	0	22829	0	120628	143456
10	C4+C5+C6	265225	92471	62402	29089	777619	197561	1424367
11		0	0	0	28242	0	191806	220048
12		0	0	0	27419	0	186220	213639
13		0	0	0	26620	0	180796	207416
14		0	0	0	25845	0	175530	201375
15	C7+C1	227534	25428	31659	29071	418344	211997	944032
16		0	0	0	28224	0	205822	234046
17		0	0	0	27402	0	199827	227229
18		0	0	0	26604	0	194007	220611
19		0	0	0	25829	0	188356	214185
20	C2+C3	103385	22085	28954	35711	373351	220310	783796
<b>Total</b>		<b>1274249</b>	<b>386166</b>	<b>230482</b>	<b>544644</b>	<b>2528620</b>	<b>3374853</b>	<b>8339014</b>

## Appendix 4 (continued)

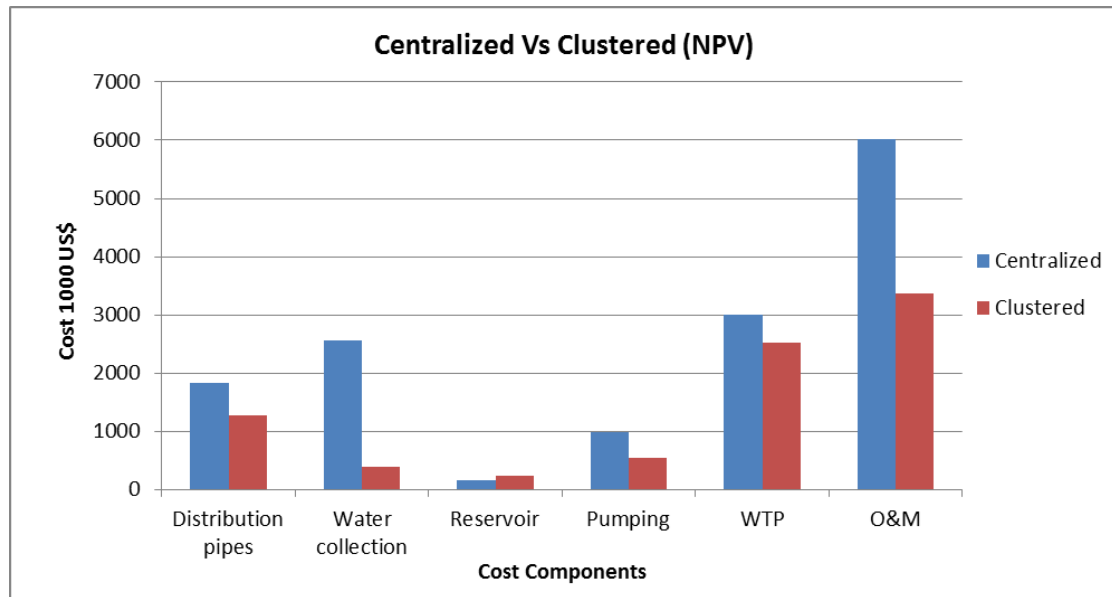

Figure A.4 Cost comparison between centralized WSS with conventional WTP and clustered systems with SSF

The cost calculation for the centralized WSS is shown below:

$$\text{NPV} = 14538073 \text{ US\$}$$

$$A_t = \frac{(1+r)^t - 1}{r * (1+r)^t} = \frac{(1+0.03)^{20} - 1}{0.03 * (1+0.03)^{20}} = 15$$

$$\text{EAC} = \frac{\text{NPV}}{A_t} = 977187 \text{ US\$}$$

The cost calculation for the clustered WSS is shown below:

$$\text{NPV} = 8339014 \text{ US\$}$$

$$\text{EAC} = \frac{\text{NPV}}{A_t} = 560513 \text{ US\$}$$



#### **Appendix 4 (continued)**

The comparison of EAC for this case-study shows that clustered WSS (US \$560,513) is cheaper than the centralized WSS (US \$977,187). This means the clustered WSS offers an annual cost saving of 43% every year than centralized WSS. This is because the small scale clustered UWS offer huge cost saving from pipe network and pumping energy. In addition the investment expense incurred due to the economic scale of treatment units is minimized by exploiting the opportunity associated with small scale low cost treatment units. Thus for the case we studied in this chapter, small clustered WSS with small scale low cost treatment units offer huge cost saving.